

K
Kawasaki

NinjaZX-10
ZX-10

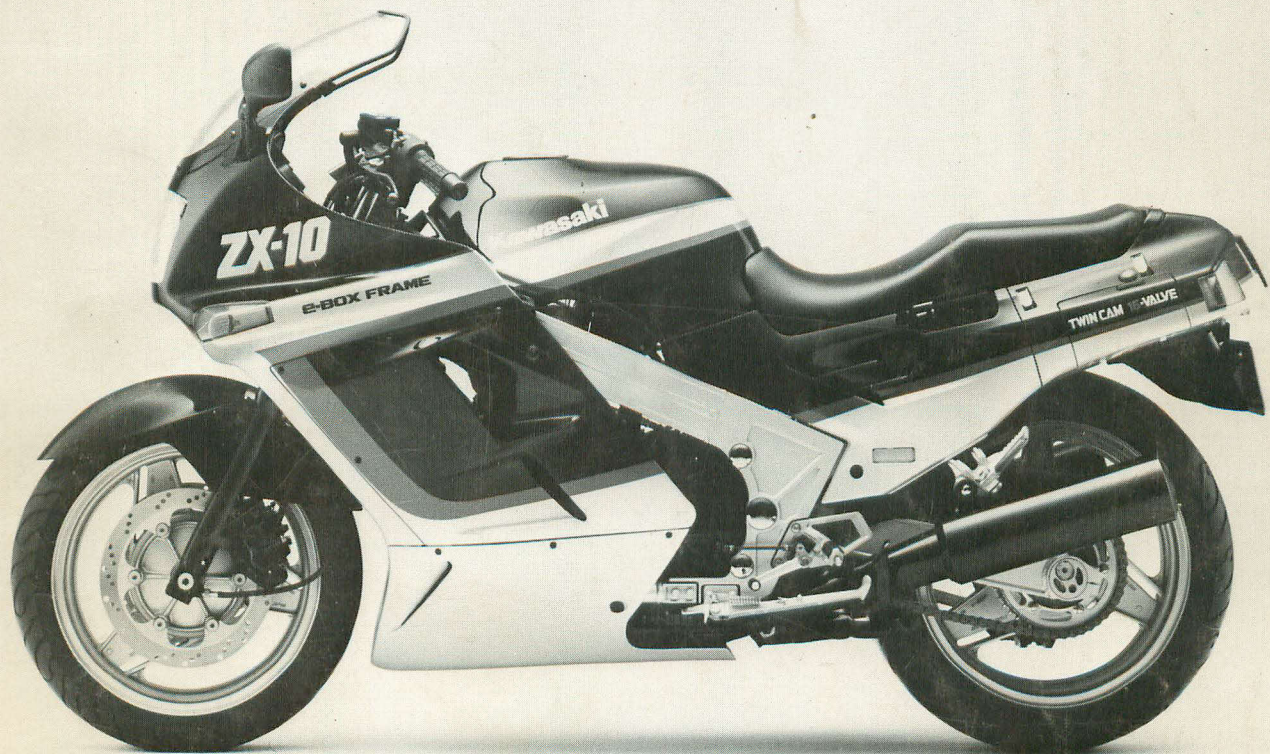

Motorcycle
Service Manual

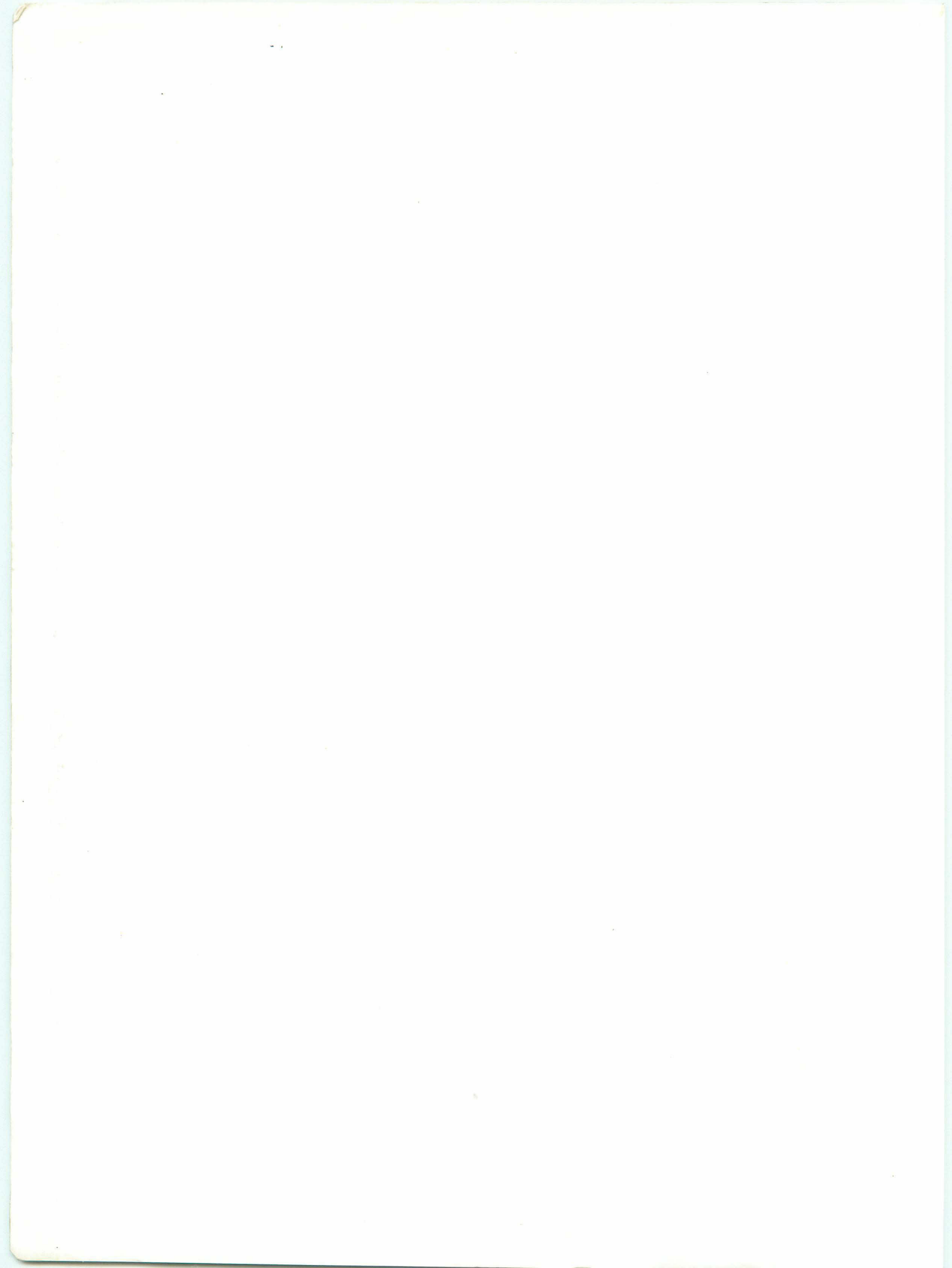

Quick Reference Guide

General Information	1
Fuel System	2
Cooling System	3
Engine Top End	4
Clutch	5
Engine Lubrication System	6
Engine Removal/Installation	7
Crankshaft/Transmission	8
Wheels/Tires	9
Final Drive	10
Brakes	11
Suspension	12
Steering	13
Frame	14
Electrical System	15
Appendix	16

This quick reference guide will assist you in locating a desired topic or procedure.

- Bend the pages back to match the black tab of the desired chapter number with the black tab on the edge at each table of contents page.
- Refer to the sectional table of contents for the exact pages to locate the specific topic required.

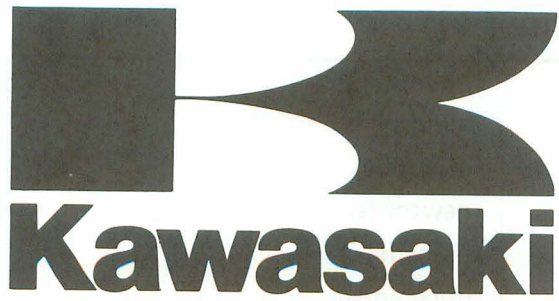

NinjaZX-10 ZX-10

Motorcycle Service Manual

All rights reserved. No parts of this publication may be reproduced, stored in a retrieval system, or transmitted in any form or by any means, electronic mechanical photocopying, recording or otherwise, without the prior written permission of Quality Assurance Department/Consumer Products & Components Group/Kawasaki Heavy Industries, Ltd., Japan.

No liability can be accepted for any inaccuracies or omissions in this publication, although every possible care has been taken to make it as complete and accurate as possible.

The right is reserved to make changes at any time without prior notice and without incurring an obligation to make such changes to products manufactured previously. See your Motorcycle dealer for the latest information on product improvements incorporated after this publication.

All information contained in this publication is based on the latest product information available at the time of publication. Illustrations and photographs in this publication are intended for reference use only and may not depict actual model component parts.

LIST OF ABBREVIATIONS

A	ampere(s)	lb	pound(s)
ABDC	after bottom dead center	m	meter(s)
AC	alternating current	min	minute(s)
ATDC	after top dead center	N	newton(s)
BBDC	before bottom dead center	Pa	pascal(s)
BDC	bottom dead center	PS	horsepower
BTDC	before top dead center	psi	pound(s) per square inch
°C	degree(s) Celsius	r	revolution
DC	direct current	rpm	revolution(s) per minute
F	farad(s)	TDC	top dead center
°F	degree(s) Fahrenheit	TIR	total indicator reading
ft	foot, feet	V	volt(s)
g	gram(s)	W	watt(s)
h	hour(s)	Ω	ohm(s)
L	liter(s)		



**WARNING
CONTAINS
ASBESTOS**

Breathing asbestos
dust is dangerous
to health

Follow safety
instructions

This warning may apply to any of the following components or any assembly containing one or more of these components:—

- Brake Shoes or Pads
- Clutch Friction Material
- Gaskets
- Insulators

SAFETY INSTRUCTIONS

- Operate if possible out of doors or in a well ventilated place.
- Preferably use hand tools or low speed tools equipped, if necessary, with an appropriate dust extraction facility. If high speed tools are used, they should always be so equipped.
- If possible, dampen before cutting or drilling.
- Dampen dust and place it in properly closed receptacle and dispose of it safely.

Read OWNER'S MANUAL before operating

EMISSION CONTROL INFORMATION

To protect the environment in which we all live, Kawasaki has incorporated crankcase emission (1) and exhaust emission (2) control systems in compliance with applicable regulations of the United States Environmental Protection Agency and California Air Resources Board. Additionally, Kawasaki has incorporated an evaporative emission control system (3) in compliance with applicable regulations of the California Air Resources Board on vehicles sold in California only.

1. Crankcase Emission Control System

This system eliminates the release of crankcase vapors into the atmosphere. Instead, the vapors are routed through an oil separator to the intake side of the engine. While the engine is operating, the vapors are drawn into combustion chamber, where they are burned along with the fuel and air supplied by the carburetion system.

2. Exhaust Emission Control System

This system reduces the amount of pollutants discharged into the atmosphere by the exhaust of this motorcycle. The fuel and ignition systems of this motorcycle have been carefully designed and constructed to ensure an efficient engine with low exhaust pollutant levels.

3. Evaporative Emission Control System

Vapors caused by fuel evaporation in the fuel system are not vented into the atmosphere. Instead, fuel vapors are routed into the running engine to be burned, or stored in a canister when the engine is stopped. Liquid fuel is caught by a vapor separator and returned to the fuel tank.

The Clean Air Act, which is the Federal law covering motor vehicle pollution, contains what is commonly referred to as the Act's "tampering provisions."

"Sec. 203(a) The following acts and the causing thereof are prohibited...

(3)(A) for any person to remove or render inoperative any device or element of design installed on or in a motor vehicle or motor vehicle engine in compliance with regulations under this title prior to its sale and delivery to the ultimate purchaser, or for any manufacturer or dealer knowingly to remove or render inoperative any such device or element of design after such sale and delivery to the ultimate purchaser.

(3)(B) for any person engaged in the business of repairing, servicing, selling, leasing, or trading motor vehicles or motor vehicle engines, or who operates a fleet of motor vehicles knowingly to remove or render inoperative any device or element of design installed on or in a motor vehicle or motor vehicle engine in compliance with regulations under this title following its sale and delivery to the ultimate purchaser..."

(Continued on next page.)

NOTE

o *The phrase "remove or render inoperative any device or element of design" has been generally interpreted as follows:*

1. *Tampering does not include the temporary or rendering inoperative of devices or elements of design in order to perform maintenance.*
2. *Tampering could include:*
 - a. *Maladjustment of vehicle components such that the emission standards are exceeded.*
 - b. *Use of replacement parts or accessories which adversely affect the performance or durability of the motorcycle.*
 - c. *Addition of components or accessories that result in the vehicle exceeding the standards.*
 - d. *Permanently removing, disconnecting, or rendering inoperative any component or element of design of the emission control systems.*

WE RECOMMEND THAT ALL DEALERS OBSERVE THESE PROVISIONS OF FEDERAL LAW, THE VIOLATION OF WHICH IS PUNISHABLE BY CIVIL PENALTIES NOT EXCEEDING \$10,000 PER VIOLATION.

TAMPERING WITH NOISE CONTROL SYSTEM PROHIBITED

Federal law prohibits the following acts or the causing thereof: (1) The removal or rendering inoperative by any person other than for purposes of maintenance, repair, or replacement, of any device or element of design incorporated into any new vehicle for the purpose of noise control prior to its sale or delivery to the ultimate purchaser or while it is in use, or (2) the use of the vehicle after such device or element of design has been removed or rendered inoperative by any person.

Among those acts presumed to constitute tampering are the acts listed below:

- Replacement of the original exhaust system or muffler with a component not in compliance with Federal regulations.
- Removal of the muffler(s) or any internal portion of the muffler(s).
- Removal of the air box or air box cover.
- Modifications to the muffler(s) or air intake system by cutting, drilling, or other means if such modifications result in increased noise levels.

Foreword

This manual is designed primarily for use by trained mechanics in a properly equipped shop. However, it contains enough detail and basic information to make it useful to the owner who desires to perform his own basic maintenance and repair work. A basic knowledge of mechanics, the proper use of tools, and workshop procedures must be understood in order to carry out maintenance and repair satisfactorily. Whenever the owner has insufficient experience or doubts his ability to do the work, all adjustments, maintenance, and repair should be carried out only by qualified mechanics.

In order to perform the work efficiently and to avoid costly mistakes, read the text, thoroughly familiarize yourself with the procedures before starting work, and then do the work carefully in a clean area. Whenever special tools or equipment are specified, do not use makeshift tools or equipment. Precision measurements can only be made if the proper instruments are used, and the use of substitute tools may adversely affect safe operation.

For the duration of your warranty period, especially, we recommend that all repairs and scheduled maintenance be performed in accordance with this service manual. Any owner maintenance or repair procedure not performed in accordance with this manual may void the warranty.

To get the longest life out of your Motorcycle:

- Follow the Periodic Maintenance Chart in the Service Manual.
- Be alert for problems and non-scheduled maintenance.
- Use proper tools and genuine Kawasaki Motorcycle parts. Special tools, gauges, and testers that are necessary when servicing Kawasaki motorcycles are introduced by the Special Tool Manual. Genuine parts provided as spare parts are listed in the Parts Catalog.
- Follow the procedures in this manual carefully. Don't take shortcuts.
- Remember to keep complete records of maintenance and repair with dates and any new parts installed.

How to Use this Manual

In preparing this manual, we divided the product into its major systems. These systems became the manual's chapters. All information for a particular system from adjustment through disassembly and inspection is located in a single chapter.

The Quick Reference Guide shows you all of the product's system and assists in locating their chapters. Each chapter in turn has its own comprehensive Table of Contents.

The Periodic Maintenance Chart is located in the General Information chapter. The chart gives a time schedule for required maintenance operations.

If you want spark plug information, for example, go to the Periodic Maintenance Chart first. The chart tells you how frequently to clean and gap the plug. Next, use the Quick Reference Guide to locate the Electrical System chapter. Then, use the Table of Contents on the first page of the chapter to find the Spark Plug section.

Whenever you see these WARNING and CAUTION symbols, heed their instructions! Always follow safe operating and maintenance practices.

WARNING

- This warning symbol identifies special instructions or procedures which, if not correctly followed, could result in personal injury, or loss of life.

CAUTION

- This caution symbol identifies special instructions or procedures which, if not strictly observed, could result in damage to or destruction of equipment.

This manual contains five more symbols (in addition to WARNING and CAUTION) which will help you distinguish different types of information.

NOTE

- This note symbol indicates points of particular interest for more efficient and convenient operation.

- Indicates a procedural step or work to be done.
- Indicates a procedural sub-step or how to do the work of the procedural step it follows. It also precedes the text of a WARNING, CAUTION, or NOTE.
- ★ Indicates a conditional step or what action to take based on the results of the test or inspection in the procedural step or sub-step it follows.
- ☆ Indicates a conditional sub-step or what action to take based upon the results of the conditional step it follows.

In most chapters an exploded view illustration of the system components follows the Table of Contents. In these illustrations you will find the instructions indicating which parts require specified tightening torque, oil, grease or a locking agent during assembly.

General Information

Table of Contents

Before Servicing	1-2
Model Identification	1-4
General Specifications	1-5
Periodic Maintenance Chart	1-8
Torque and Locking Agent	1-10
Cable, Wire and Hose Routing	1-14

1-2 GENERAL INFORMATION

Before Servicing

Before starting to service a motorcycle, careful reading of the applicable section is recommended to eliminate unnecessary work. Photographs, diagrams, notes, cautions, warnings, and detailed descriptions have been included wherever necessary. Nevertheless, even a detailed account has limitations, a certain amount of basic knowledge is also required for successful work.

Especially note the following:

- (1) **Dirt**

Before removal and disassembly, clean the motorcycle. Any dirt entering the engine or other parts will work as an abrasive and shorten the life of the motorcycle. For the same reason, before installing a new part, clean off any dust or metal filings.
- (2) **Battery Ground**

Remove the ground (—) lead from the battery before performing any disassembly operations on the motorcycle. This prevents:

 - (a) the possibility of accidentally turning the engine over while partially disassembled.
 - (b) sparks at electrical connections which will occur when they are disconnected.
 - (c) damage to electrical parts.
- (3) **Tightening Sequence**

Generally, when installing a part with several bolts, nuts, or screws, they should all be started in their holes and tightened to a snug fit. Then tighten them evenly in a cross pattern. This is to avoid distortion of the part and/or causing gas or oil leakage. Conversely when loosening the bolts, nuts, or screws, first loosen all of them by about a quarter of turn and then remove them. Where there is a tightening sequence indication in this Service Manual, the bolts, nuts, or screws must be tightened in the order and method indicated.
- (4) **Torque**

The torque values given in this Service Manual should always be adhered to. Either too little or too much torque may lead to serious damage. Use a good quality, reliable torque wrench.
- (5) **Force**

Common sense should dictate how much force is necessary in assembly and disassembly. If a part seems especially difficult to remove or install, stop and examine what may be causing the problem. Whenever tapping is necessary, tap lightly using a wooden or plastic faced mallet. Use an impact driver for screws (particularly for the removal of screws held by a locking agent) in order to avoid damaging the screw heads.
- (6) **Edges**

Watch for sharp edges, especially during major engine disassembly and assembly. Protect your hands with gloves or a piece of thick cloth when lifting the engine or turning it over.
- (7) **High Flash-point Solvent**

A high flash-point solvent is recommended to reduce fire danger. A commercial solvent commonly available in North America is Stoddard solvent (generic name). Always follow manufacturer and container directions regarding the use of any solvent.
- (8) **Gasket, O-ring**

Do not reuse a gasket or O-ring once it has been in service. The mating surfaces around the gasket should be free of foreign matter and perfectly smooth to avoid oil or compression leaks.
- (9) **Liquid Gasket, Non-permanent Locking Agent**

Follow manufacturer's directions for cleaning and preparing surfaces where these compounds will be used. Apply sparingly. Excessive amounts may block engine oil passages and cause serious damage. An example of a non-permanent locking agent commonly available in North America is Loctite Lock'n Seal (Blue).
- (10) **Press**

A part installed using a press or driver, such as a wheel bearing, should first be coated with oil on its outer or inner circumference so that it will go into place smoothly.
- (11) **Ball Bearing**

When installing a ball bearing, the bearing race which is affected by friction should be pushed by a suitable driver. This prevents severe stress on the balls and races, and prevents races and balls from being dented. Press a ball bearing until it stops at the stop in the hole or on the shaft.

(12) Oil Seal and Grease Seal

Replace any oil or grease seals that were removed with new ones, as removal generally damages seals.

When pressing in a seal which has manufacturer's marks, press it in with the marks facing out. Seals should be pressed into place using a suitable driver, which contacts evenly with the side of seal, until the face of the seal is even with the end of the hole.

(13) Seal Guide

A seal guide is required for certain oil or grease seals during installation to avoid damage to the seal lips. Before a shaft passes through a seal, apply a little oil, preferably high temperature grease on the lips to reduce rubber to metal friction.

(14) Circlip, Retaining Ring

Replace any circlips and retaining rings that were removed with new ones, as removal weakens and deforms them. When installing circlips and retaining rings, take care to compress or expand them only enough to install them and no more.

(15) Lubrication

Engine wear is generally at its maximum while the engine is warming up and before all the rubbing surfaces have an adequate lubricative film. During assembly, oil or grease (whichever is more suitable) should be applied to any rubbing surface which has lost its lubricative film. Old grease and dirty oil should be cleaned off. Deteriorated grease has lost its lubricative quality and may contain abrasive foreign particles.

Don't use just any oil or grease. Some oils and greases in particular should be used only in certain applications and may be harmful if used in an application for which they are not intended. This manual makes reference to molybdenum disulfide grease (MoS₂) in the assembly of certain engine and chassis parts. Always check manufacturer recommendations before using such special lubricants.

(16) Electrical Wires

All the electrical wires are either single-color or two-color and, with only a few exceptions, must be connected to wires of the same color. On any of the two-color wires there is a greater amount of one color and a lesser amount of a second color, so a two-color wire is identified by first the primary color and then the secondary color. For example, a yellow wire with thin red stripes is referred to as a "yellow/red" wire; it would be a "red/yellow" wire if the colors were reversed to make red the main color.

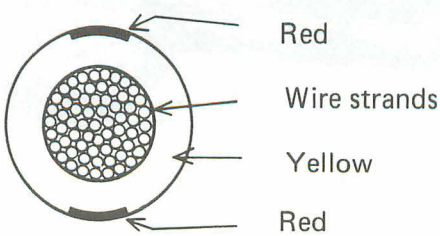
Wire (cross-section)	Name of Wire Color
	Yellow/red

(17) Replacement Parts

When there is a replacement instruction, replace these parts with new ones every time they are removed. These replacement parts will be damaged or lose their original function once removed.

(18) Inspection

When parts have been disassembled, visually inspect these parts for the following conditions or other damage. If there is any doubt as to the condition of them, replace them with new ones.

Abrasion	Crack	Hardening	Warp
Bent	Dent	Scratch	Wear
Color change	Deterioration	Seizure	

(19) Service Data

Numbers of service data in this text have following meanings:

"Standards": Show dimensions or performances which brand-new parts or systems have.

"Service limits": Indicate the usable limits. If the measurement shows excessive wear or deteriorated performance, replace the damaged parts.

1-4 GENERAL INFORMATION

.....
Model Identification
.....

ZX1000-B1



ZX1000-B2



ZX1000-B3



General Specifications

Item	ZX1000-B1/B2	ZX1000-B3
Dimensions:		
Overall length	2 170 mm, (G) (N) (S) (Sw) (W) 2 200 mm	←
Overall width	715 mm	←
Overall height	1 240 mm	←
Wheelbase	1 490 mm	←
Road clearance	125 mm	←
Seat height	790 mm	←
Dry weight	222 kg, (Cal) 222.5 kg	←
Curb weight: Front	126 kg, (Cal) 126.5 kg	←
Rear	128 kg	←
Fuel tank capacity	22.0 L	←
Performance:		
Climbing ability	30°	←
Braking distance	12.5 m from 50 km/h	←
Minimum turning radius	3.1 m	← Climbing ability
Engine:		
Type	4-stroke, DOHC, 4-cylinder	←
Cooling system	Liquid-cooled	←
Bore and stroke	74.0 x 58.0 mm	←
Displacement	997 mL	←
Compression ratio	11.0, (F) 10.2	←
Maximum horsepower	Max: 101 kW (137 PS) @10 000 r/min (rpm), (AS) (Sw) 73.6 kW (100 PS) @8 800 r/min (rpm), (UK) 91.9 kW (125 PS) @10 000 r/min (rpm) (ISO4106), (S) 53.0 kW (72 PS) @6 000 r/min (rpm), (W) 73.6 kW (100 PS) @8 800 r/min (rpm)(DIN), (F) 75.1 kW (—) @8 800 r/min (rpm) (UTAC'S norm)	← ← (Sw) 65.5 kW (89 PS) @9 000 r/min (rpm), ← ←
Maximum torque	103 N-m (10.5 kg-n, 76 ft-lb) @9 000 r/min (rpm), (S) 85 N-m (8.7 kg-m, 63 ft-lb) @6 000 r/min (rpm), (AS) (Sw) 89 N-m (9.1 kg-m, 66 ft-lb) @6 800 r/min (rpm), (F) (UK) — (W) 89 N-m (9.1 kg-m, 66 ft-lb) @6 800 r/min (rpm) (DIN)	← ← ← (Sw) 82 N-m (8.4 kg-m, 61 ft-lb) @6 000 r/min (rpm), ← ← (W) 85 N-m (8.7 kg-m, 63 ft-lb) @6 500 r/min (rpm)(DIN), ← (E) 102 N-m (10.4 kg-m, 75 ft-lb) @9 000 r/min (rpm)
Carburetor system	Carburetors, Keihin CVKD36 x 4	←
Starting system	Electric starter	←
Ignition system	Battery and coil (transistorized)	←

1-6 GENERAL INFORMATION

Items	ZX1000-B1/B2/B3
Timing advance	Electronically advanced
Ignition timing	From 10° BTDC @1 000 r/min (rpm) to 35° BTDC @7 500 r/min (rpm) (S) From 10° BTDC @1 200 r/min (rpm) to 35° BTDC @7 500 r/min (rpm)
Spark plug	NGK CR9E or ND U27ESR-N (U)(A)(I)(SA) NGK C9E or ND U27ES-N
Cylinder numbering method	Left to right, 1-2-3-4
Firing order	1-2-4-3
Valve timing:	
Inlet	Open 38° BTDC, (F) 20° BTDC Close 68° ABDC, (F) 50° ABDC Duration 286°, (F) 250°
Exhaust	Open 60° BBDC, (F) 45° BBDC Close 40° ATDC, (F) 25° ATDC Duration 280°, (F) 250°
Lubrication system	Forced lubrication (wet sump with cooler)
Engine oil:	
Grade	SE or SF class
Viscosity	SAE 10W40, 10W50, 20W40, or 20W50
Capacity	4.0 L
Drive Train:	
Primary reduction system:	
Type	Gear
Reduction ratio	1.732 (97/56)
Clutch type	Wet multi disc
Transmission:	
Type	6-speed, constant mesh, return shift
Gear ratios:	
1st	2.800 (42/15)
2nd	2.000 (38/19)
3rd	1.590 (35/22)
4th	1.333 (32/24)
5th	1.153 (30/26)
6th	1.035 (29/28)
Final drive system:	
Type	Chain drive
Reduction ratio	2.647 (45/17)
Overall drive ratio	4.748

Items	ZX1000-B1/B2/B3
Frame:	
Type	Tubular, double cradle
Caster (rake angle)	26.5°
Trail	101 mm
Front tire:	
Type	Tubeless
Size	120/70VR17-V280,120/70VB17-V280 or120/70 ZR17
Rear tire:	
Type	Tubeless
Size	160/60VR18-V280,160/60VB18-V280 or 160/60 ZR18
Front suspension:	
Type	Telescopic fork
Wheel travel	135 mm
Rear suspension:	
Type	Swing arm (uni-trak)
Wheel travel	120 mm
Brake type:	
Front	Dual disc
Rear	Single disc
Electrical Equipment:	
Battery	12 V 14 Ah
Headlight:	
Type	Semi-sealed beam
Bulb	12 V 60/55 W (quartz-halogen)
Tail/brake light	12 V 5/21 W x 2, (SA) (U) (C) 12 V 8/27 W x 2
Alternator:	
Type	Three-phase AC
Rated output	24 A @6 000 r/min (rpm), 14 V
Voltage regulator:	
Type	Short-circuit

Specifications subject to change without notice, and may not apply to every country.

- (A) : Australian Model
- (C) : Canadian Model
- (Cal) : Californian Model
- (S) : Swiss Model
- (SA) : South African Model
- (U) : US Model
- (Sw) : Swedish Model
- (W) : West German Model

- (UK) : UK Model
- (F) : French Model
- (G) : Greek Model
- (N) : Norwegian Model
- (AS) : Austrian Model
- (I) : Italian Model
- (E) : European Model

1-8 GENERAL INFORMATION

Periodic Maintenance Chart

The scheduled maintenance must be done in accordance with this chart to keep the motorcycle in good running condition. **The initial maintenance is vitally important and must not be neglected.**

OPERATION	FREQUENCY	*ODOMETER READING						
		800 km	5,000 km	10,000 km	15,000 km	20,000 km	25,000 km	30,000 km
Sparl plug – clean	Every	•	•	•	•	•	•	•
Spark plug – check †	Every	•	•	•	•	•	•	•
Valve clearance – check †	Every	•	•	•	•	•	•	•
Air suction valve (US),(S) – check †	Every	•	•	•	•	•	•	•
Air cleaner element – clean	Every	•	•	•	•	•	•	•
Air cleaner element – replace	5 cleanings				•			
Throttle grip play – check †	Every	•	•	•	•	•	•	•
Idle speed – check †	Every	•	•	•	•	•	•	•
Engine vacuum synchronization – check †	Every	•	•	•	•	•	•	•
Fuel system – check †	Every		•		•		•	
Coolant – change	2 years						•	
Evaporative emission control system (Cal) – check †	Every	•	•	•	•	•	•	•
Engine oil – change	year	•	•	•	•	•	•	•
Oil filter – replace	Every	•	•	•	•	•	•	•
Radiator hoses, connections – check †	year	•	•	•	•	•	•	•
Fuel Filter – replace	Every		•		•		•	
Fuel hose – replace	4 years							
Clutch fluid level – check †	month	•	•	•	•	•	•	•
Clutch fluid – change	2 years				•			
Clutch hose and pipe – replace	4 years							
Clutch master cylinder cup and dust seal – replace	2 years							
Clutch slave cylinder piston seal – replace	2 years							
Drive chain wear – check †	Every		•	•	•	•	•	•
Drive chain – lubricate	300 km							
Drive chain slack – check †	800 km							
Brake pad wear – check †	Every		•	•	•	•	•	•
Brake fluid level – check †	month	•	•	•	•	•	•	•
Brake fluid – change	2 years				•			
Brake hose – replace	4 years							

GENERAL INFORMATION 1-9

OPERATION	FREQUENCY	*ODOMETER READING						
	Whichever comes first ↓ Every	800 km	5,000 km	10,000 km	15,000 km	20,000 km	25,000 km	30,000 km
Brake master cylinder cup and dust seal – replace	2 years							
Caliper piston seal and dust seal – replace	2 years							
Brake light switch – check †		•	•	•	•	•	•	
Steering – check †		•	•	•	•	•	•	
Steering stem bearing – lubricate	2 years				•			
Front fork oil – change							•	
Tire wear – check †			•	•	•	•	•	
Swing arm pivot, uni-trak linkage – lubricate				•	•		•	
Battery electrolyte level – check †	month	•	•	•	•	•	•	
General lubrication – perform			•	•	•	•	•	
Nut, bolt, and fastener tightness – check †		•		•		•		•

* : For higher odometer readings, repeat at the frequency interval established here.

† : Replace, add, adjust, clean, or torque if necessary.

(Cal): California vehicle only

(US): US only

(S) : Swiss only

1-10 GENERAL INFORMATION

Torque and Locking Agent

The following tables list the tightening torque for the major fasteners requiring use of a non-permanent locking agent or liquid gasket.

Letters used in the "Remarks" column mean:

- L : Apply a non-permanent locking agent to the threads.
- LG : Apply liquid-gasket to the threads.
- O : Apply an oil to the threads and seated surface.
- S : Tighten the fasteners following the specified sequence.
- St : Stake the fasteners to prevent loosening.
- SS : Apply silicon sealant

Fastener	Torque			Remarks
	N-m	kg-m	ft-lb	
Cooling System:				
Fan Switch	18	1.8	13.0	
Water Temperature Sensor	15	1.5	11.0	SS
Bleeder Bolt	7.8	0.80	69 in-lb	
Drain Plug	7.8	0.80	69 in-lb	
Engine Top End:				
Cylinder Head Cover Bolts	9.8	1.0	87 in-lb	
Upper Chain Guide Mounting Bolts	—	—	—	L
Rear Chain Guide Mounting Bolt	20	2.0	14.5	L
Chain Tensioner Mounting Bolts	9.8	1.0	87 in-lb	
Camshaft Sprocket Bolts	15	1.5	11.0	L
Rocker Shaft End Cap	25	2.5	18.0	
Main Oil Hose Banjo Bolts	25	2.5	18.0	
Camshaft Cap Bolts	12	1.2	104 in-lb	S
Cylinder Head Bolts (10 mm Dia.)	39	4.0	29	S
Cylinder Head Bolts (11 mm Dia.)	51	5.2	38	S
Cylinder Head Bolt (6 mm Dia.)	9.8	1.0	87 in-lb	S
Cylinder Bolts	15	1.5	11.0	
Clutch:				
Clutch Hose Banjo Bolts	25	2.5	18	
Clutch Slave Cylinder Mounting Bolts	—	—	—	L
Clutch Master Cylinder Clamp Bolts	11	1.1	95 in-lb	
Clutch Hose Joint	18	1.8	13.0	
Clutch Slave Cylinder Bleeder Bolt	7.8	0.80	69 in-lb	
Clutch Spring Bolts	9.8	1.0	87 in-lb	
Clutch Hub Nut	130	13.5	98	
Right Cover Bolts	—	—	—	L (*1)
Right Cover Damper Bolts	9.8	1.0	87 in-lb	L

Fastener	Torque			Remarks
	N-m	kg-m	ft-lb	
Engine Lubrication System:				
Oil Passage Plug	18	1.8	13.0	
Drain Plug	18	1.8	13.0	
Crankcase Outside Oil Pipe Banjo Bolts	18	1.8	13.0	
Oil Pump Gear Holder Screws	—	—	—	L
Oil Pump Mounting Bolts	12	1.2	104 in-lb	L
Oil Pump Relief Valve	—	—	—	L
Main Oil Pipe Banjo Bolts	25	2.5	18.0	
Oil Pressure Switch	15	1.5	11.0	SS
Oil Pan Bolts	—	—	—	L (*2)
Oil Cooler Pipe				
Banjo Bolts (Oil cooler side)	25	2.5	18.0	
Oil Cooler Pipe				
Banjo Bolts (Oil pan side)	34	3.5	25	
Oil Filter Bolt	20	2.0	14.5	
Engine Removal/Installation:				
Engine Mounting Nuts	44	4.5	33	
Down Tube Mounting Bolts	44	4.5	33	
Crankshaft/Transmission:				
Conneting Rod Big End Cap Nuts	—	—	—	(*3)
Alternator Shaft Left End Bolt	25	2.5	18.0	
Alternator Coupling Bolt	9.8	1.0	87 in-lb	
Alternator Coupling Nut	59	6.0	43	
Alternator Shaft Chain Tensioner				
Mounting Bolts	—	—	—	L
Alternator Shaft Chain Guide Bolts	—	—	—	L
Alternator Shaft Chain Sprocket Bolts	25	2.5	18.0	
One-way Clutch Bolts	12	1.2	104 in-lb	L
Balancer Shaft Guide Pin Plate Bolt	—	—	—	L
Balancer Shaft Clamp Lever Mounting Bolt	—	—	—	L
Crankshaft Main Bearing Cap Bolts	27	2.8	20	
Crankcase Bolts (6 mm Dia.)	15	1.5	11.0	
Crankcase Bolts (8 mm Dia.)	27	2.8	20	
Shift Drum Bearing Holder Allen Bolts	—	—	—	L
Shift Drum Pin Plate Screw	—	—	—	L
External Shift Mechanism Return				
Spring Pin	—	—	—	L
External Shiaft Mecahnism Cover Screws	—	—	—	L
Neutral Switch	15	1.5	11.0	

1-12 GENERAL INFORMATION

Fastener	Torque			Remarks
	N-m	kg-m	ft-lb	
Wheels/Tires:				
Front Axle Nut	88	9.0	65	
Front Axle Clamp Bolts	20	2.0	14.5	
Tire Air Valve Nuts	1.5	0.15	13 in-lb	
Rear Axle Nut	108	11.0	80	
Final Drive:				
Engine Sprocket Nut	98	10.0	72	
Rear Sprocket Nuts	74	7.5	54	
Brakes:				
Front Brake Reservoir Cap Screws	1.5	0.15	13 in-lb	
Brake Lever Pivot Nut	5.9	0.60	52 in-lb	
Front Master Cylinder Clamp Bolts	11	1.1	95 in-lb	S
Brake Hose Banjo Bolts	25	2.5	18	
Bleed Valves	7.8	0.80	69 in-lb	
Caliper Mounting Bolts	34	3.5	25	
Disc Mounting Bolts: Front	34	3.5	25	
Rear	23	2.3	16.5	
Torque Link Bolt/Nut	25	2.5	18.0	
Brake Pedal Mounting Bolt	8.8	0.9	78 in-lb	
Suspension:				
Front Fork:				
Top Plugs	23	2.3	16.5	
Fork Clamp Bolts	28	2.9	21	
Drain Screws	1.5	0.15	13 in-lb	LG
Bottom Allen Bolts	39	4.0	29	L
Axle Clamp Bolts	21	2.1	15.0	
Rear Shock Absorber:				
Damper Adjuster Cable End	8.8	0.90	78 in-lb	
Air Valve Hose End	12	1.2	104 in-lb	
Shock Absorber Nuts	59	6.0	43	
Rocker Arm Nut	59	6.0	43	
Tie-Rod Nuts	59	6.0	43	
Swing Arm Pivot Shaft Nut	88	9.0	65	
Chain Adjuster Clamp Bolts	39	4.0	29	
Steering:				
Steering Stem Head Nut	39	4.0	29	
Steering Stem Nut	4.9	0.50	43 in-lb	
Handlebar Holder Mounting Bolts	20	2.0	14.5	

GENERAL INFORMATION 1-13

Fastener	Torque			Remarks
	N-m	kg-m	ft-lb	
Electrical System:				
Alternator Mounting Bolts	25	2.5	18.0	L
Alternator Coupling Brades Bolt	9.8	1.0	87 in-lb	
Pickup Coil Mounting Bolts	—	—	—	L
Pickup Coil Cover Bolts	—	—	—	L (*4)
Spark Plugs	14	1.4	10.0	
Timing Rotor Bolt	25	2.5	18.0	
Alternator Cover Cap Nut	4.9	0.50	43	

- (* 1): See Clutch chapter
- (*2): See Engine Lubrication chapter
- (*3): See Crankshaft/Transmission chapter
- (*4): See Electrical System chapter

1-14 GENERAL INFORMATION

Cable, Wire and Hose Routing

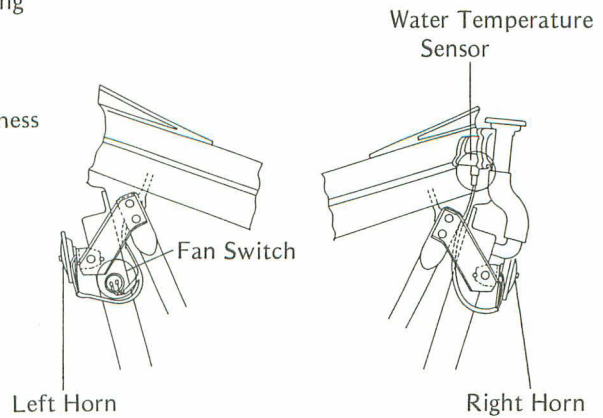
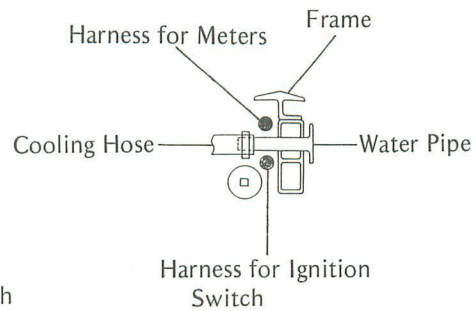
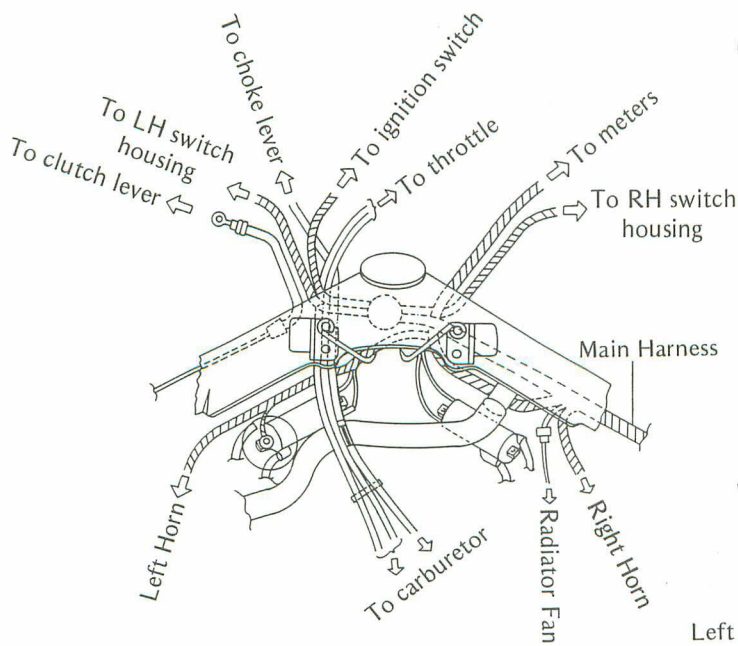
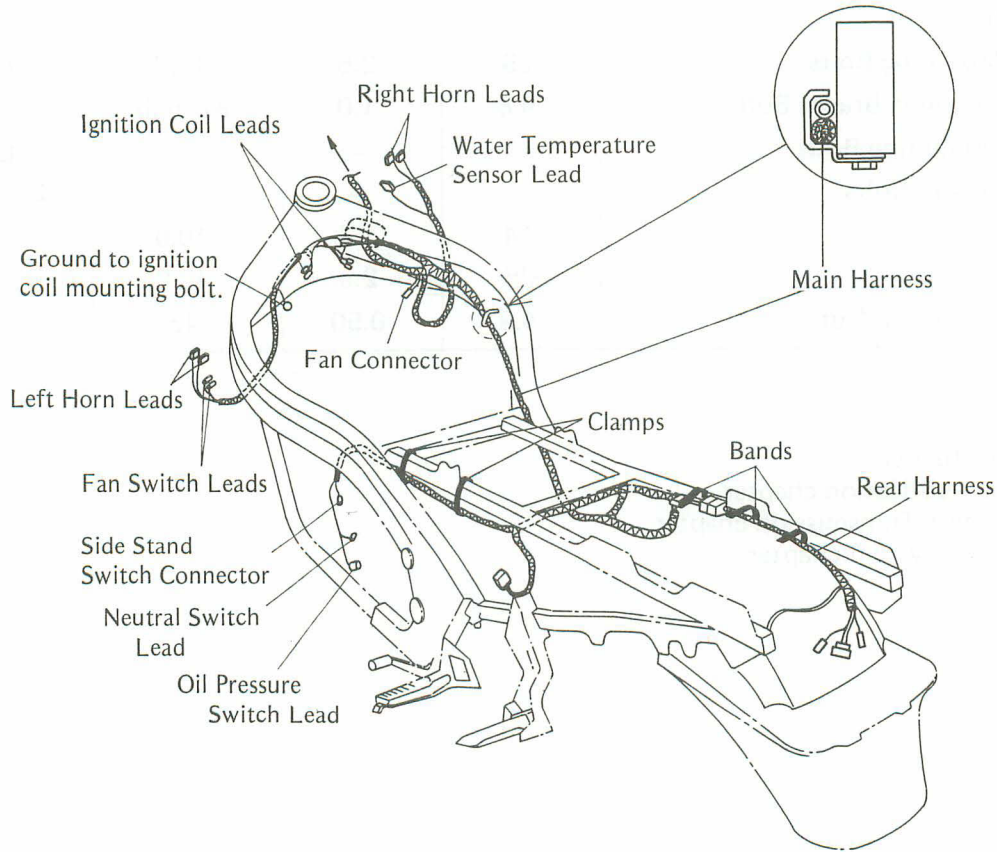

GENERAL INFORMATION 1-15

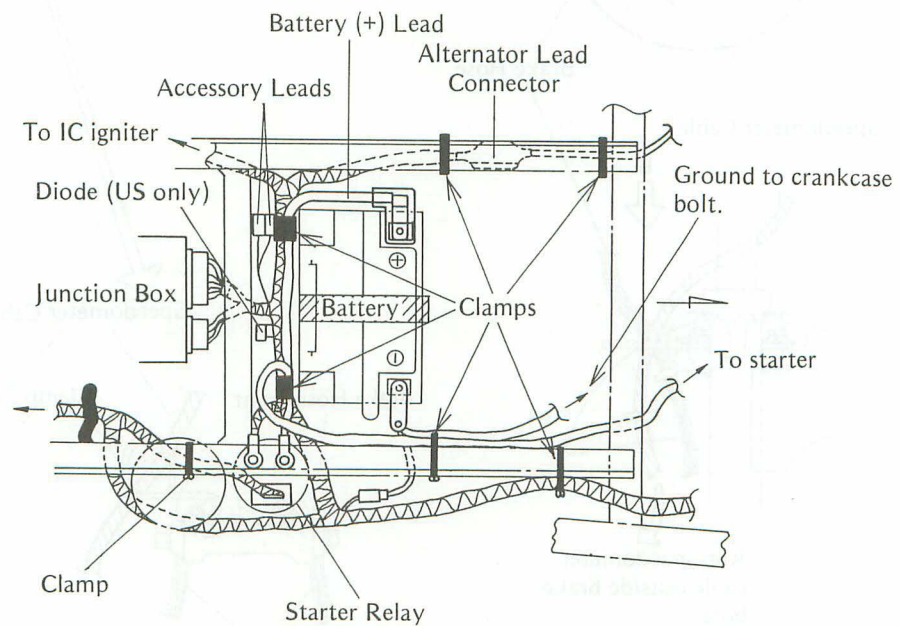
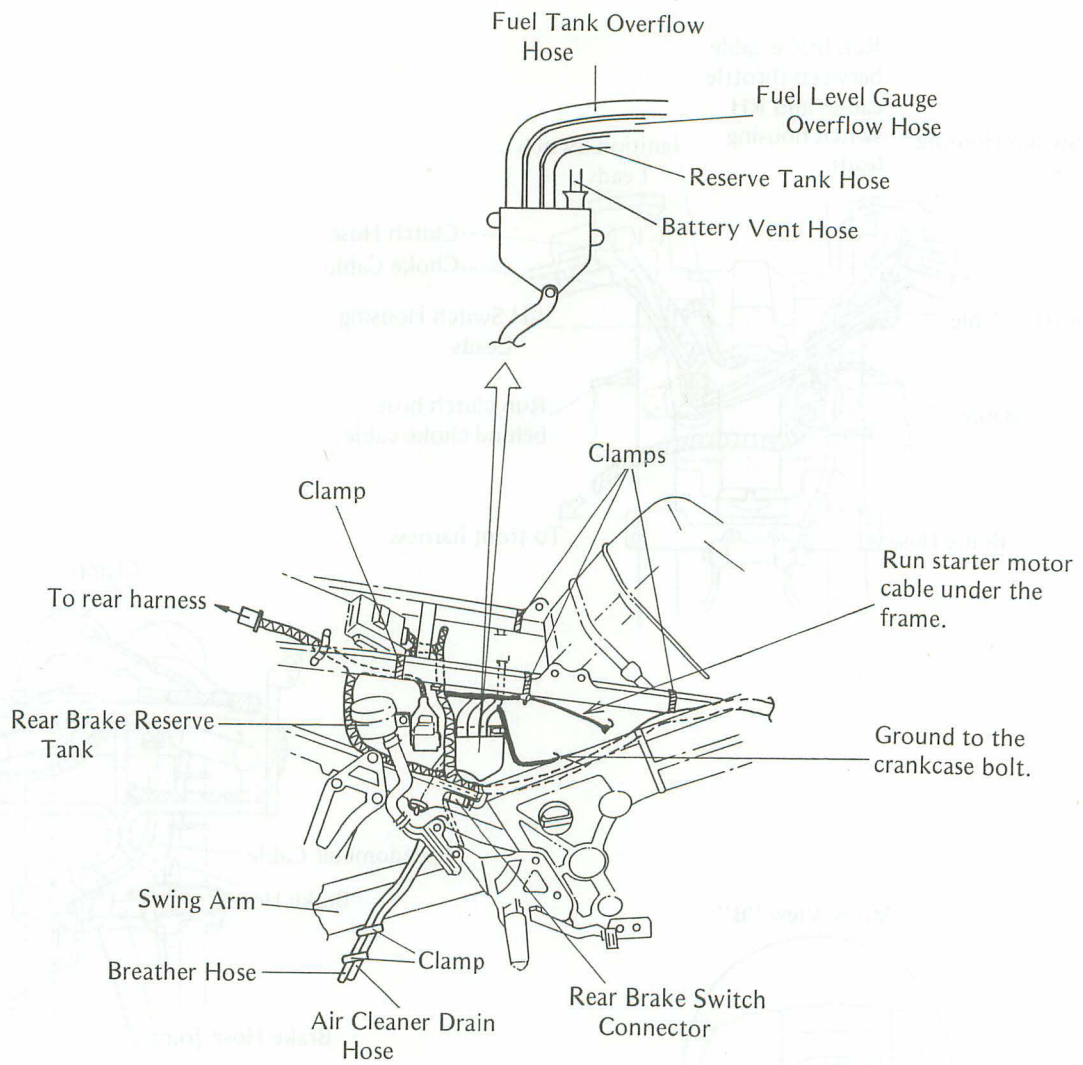

1-16 GENERAL INFORMATION

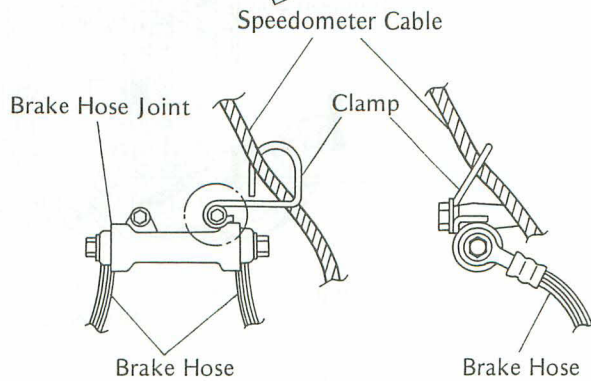
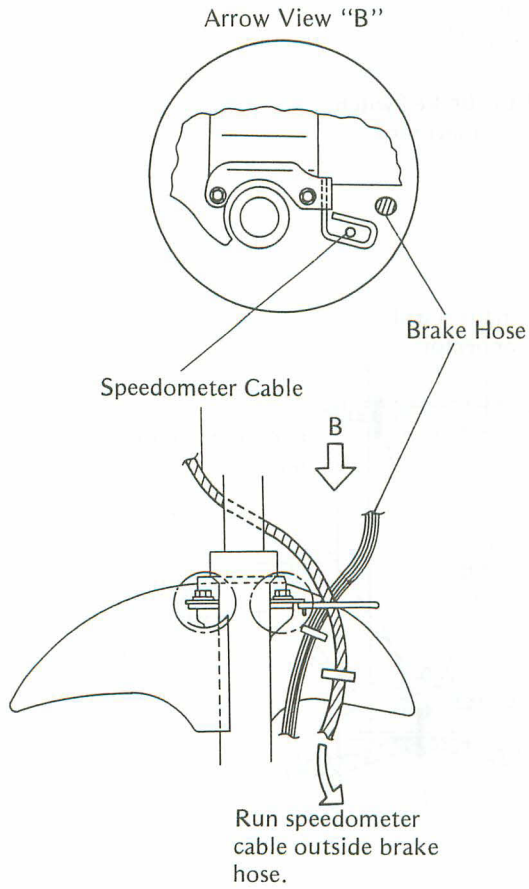
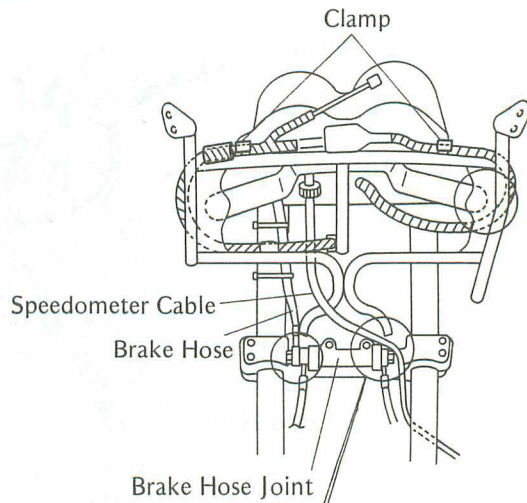
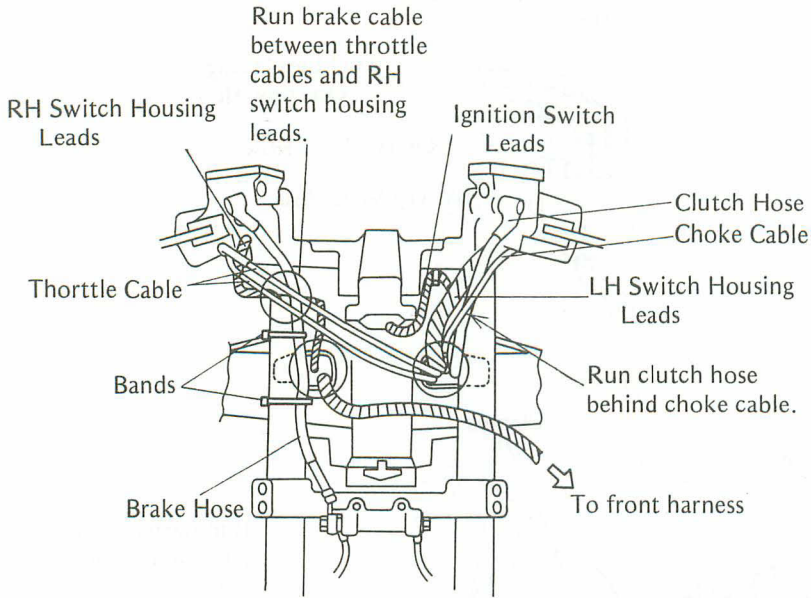

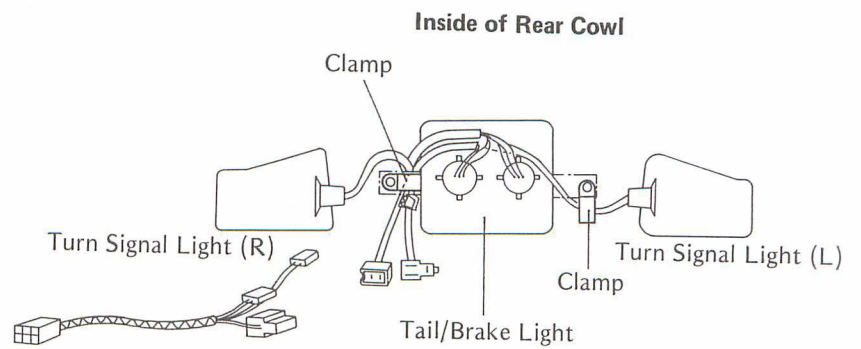
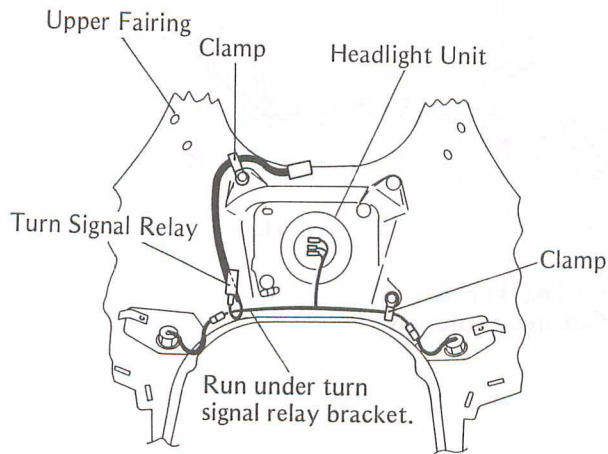
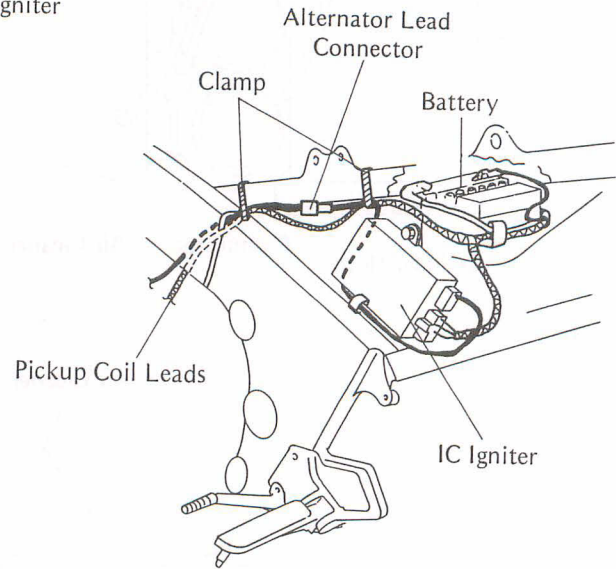
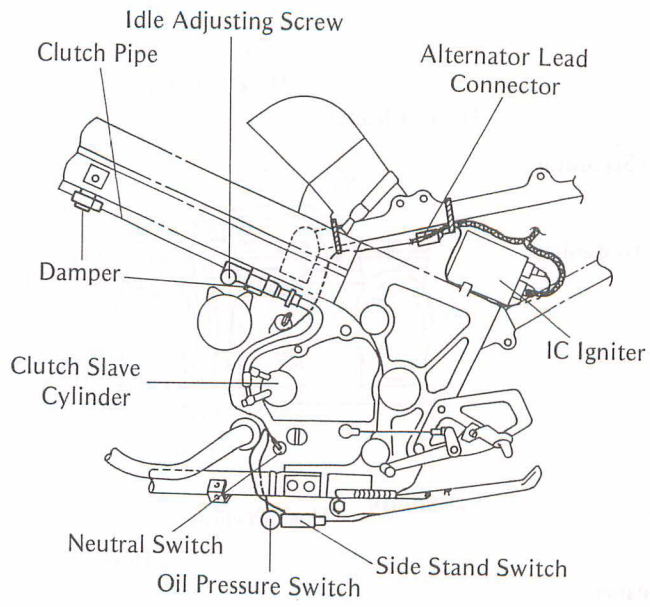

1-18 GENERAL INFORMATION

US and Swiss model

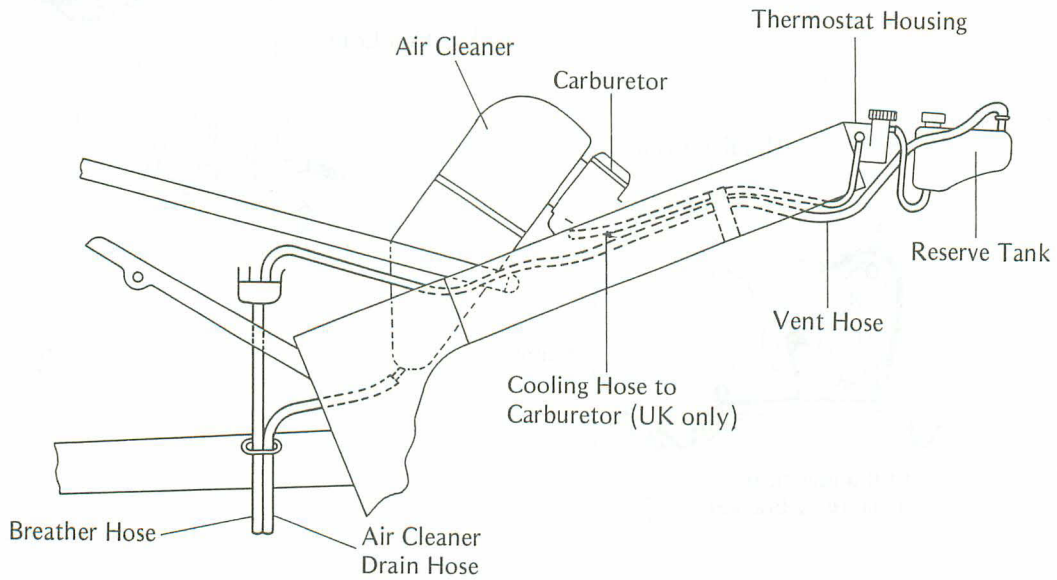
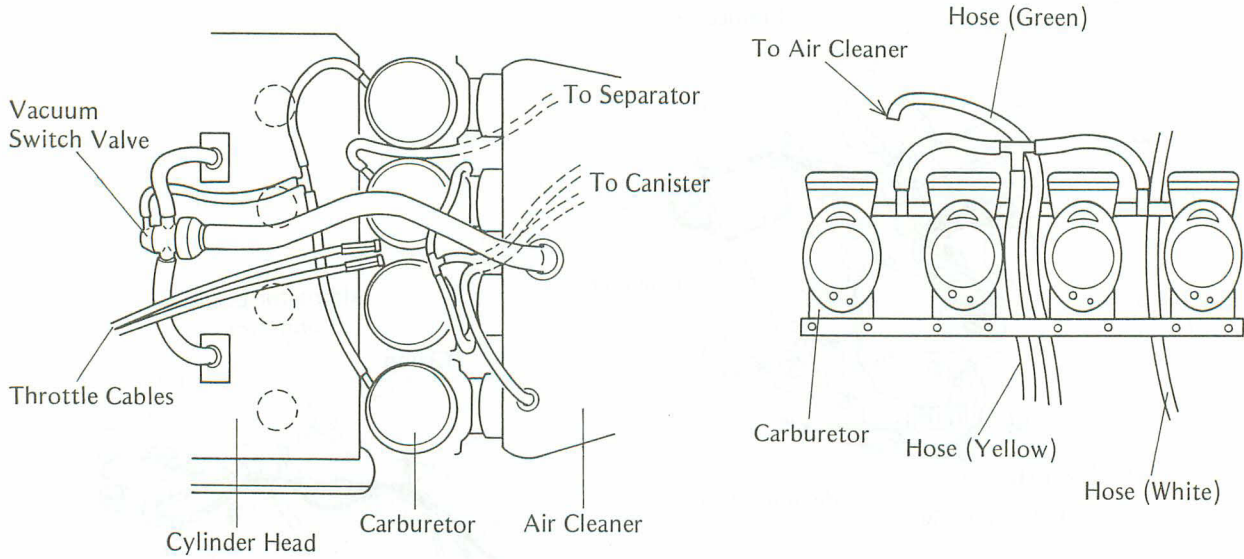

US Model

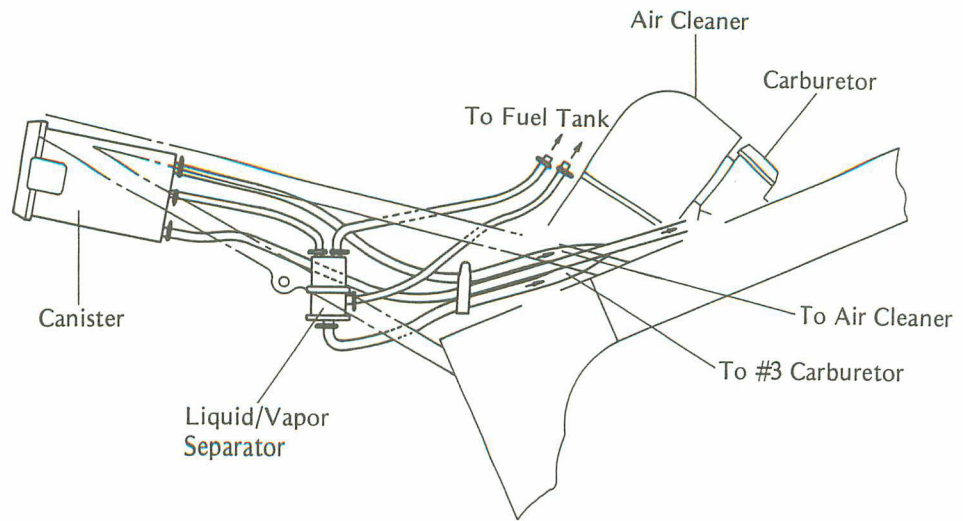

Fuel System

Table of Contents

Exploded View	2-2
Specifications	2-4
Special Tools	2-4
Throttle Grip and Cables	2-5
Throttle Cable Adjustment	2-5
Choke Cable	2-5
Choke Cable Adjustment	2-5
Carburetors	2-6
Idle Speed Adjustment	2-6
High Altitude Performance Adjustment (US model)	2-6
Carburetor Synchronization	2-7
Service Fuel Level Adjustment	2-7
Fuel System Cleanliness Inspection	2-8
Carburetor Disassembly/Assembly	2-9
Carburetor Inspection	2-10
Fuel Pump and Filter	2-11
Removal	2-11
Installation	2-11
Inspection	2-11
Air Cleaner	2-11
Element Cleaning	2-11
Evaporative Emission Control system	
(US California Vehicle only)	2-12
Parts Removal/Installation Notes	2-12
Hose Inspection (Periodic Inspection)	2-12
Separator Inspection	2-12
Separator Operation Test	2-12
Canister Inspection	2-13

2-2 FUEL SYSTEM

Exploded View

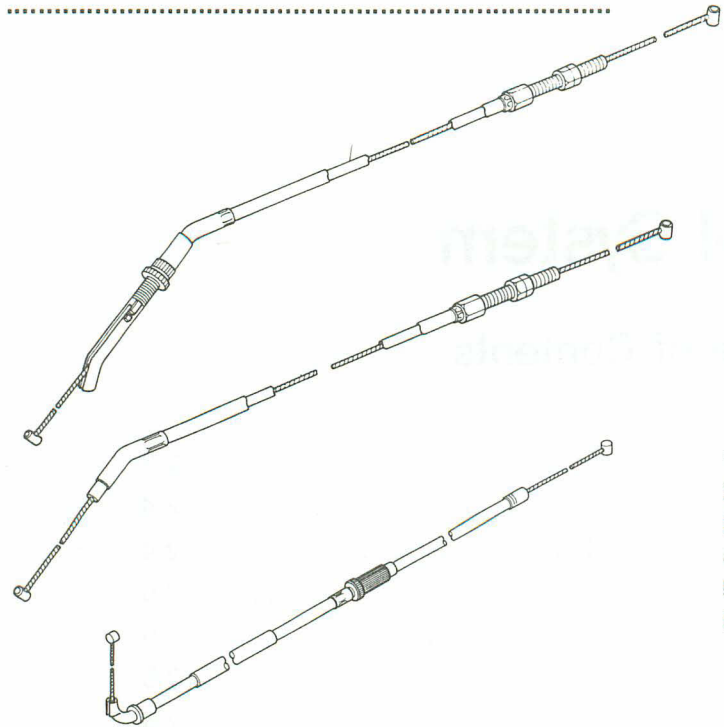

1. Jet Needle
2. Pilot Screw
3. Pilot Jet
4. Needle Jet Holder
5. Main Jet
6. Valve Needle

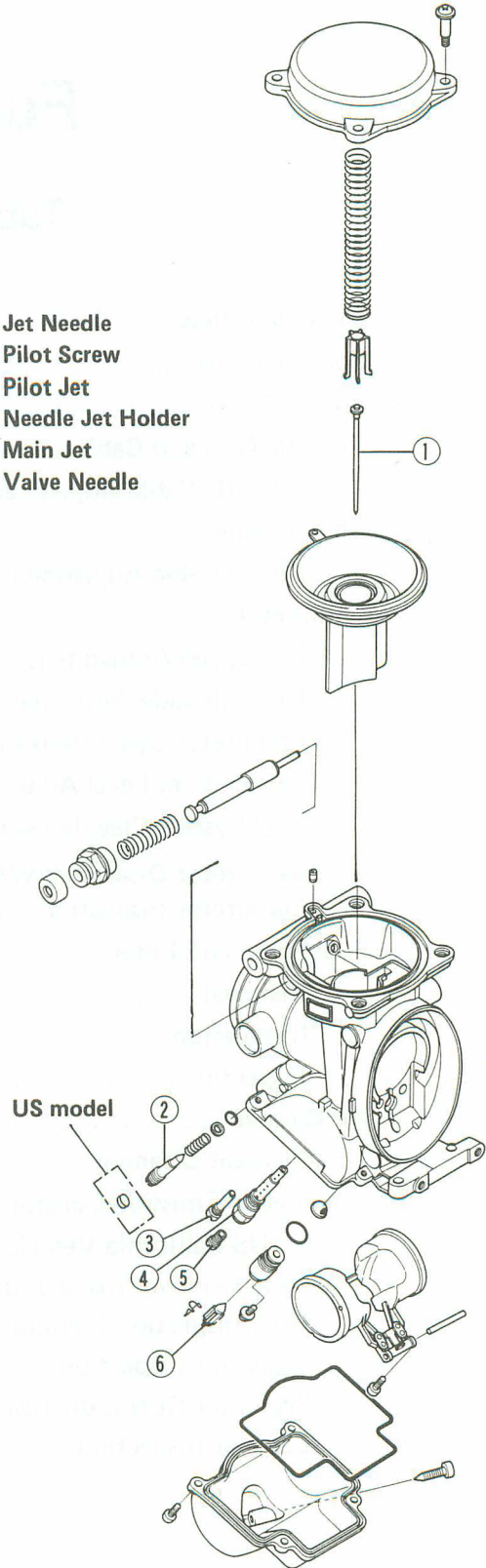
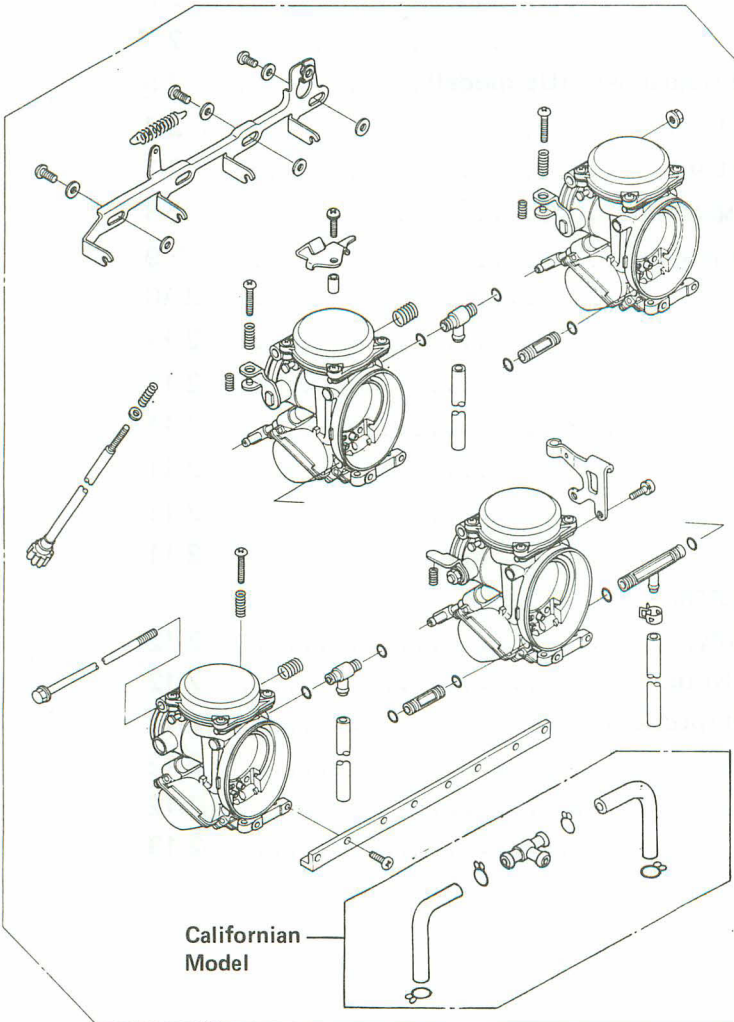

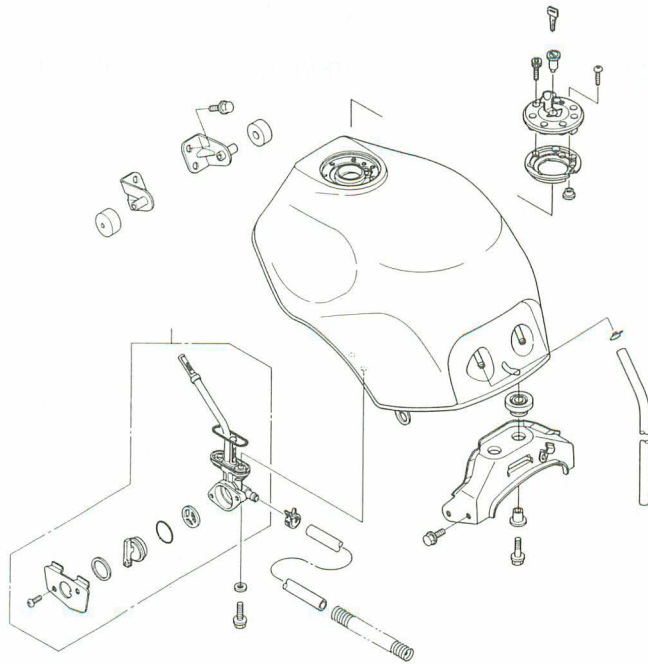

- 7. Fuel Pump
- 8. Fuel Filter

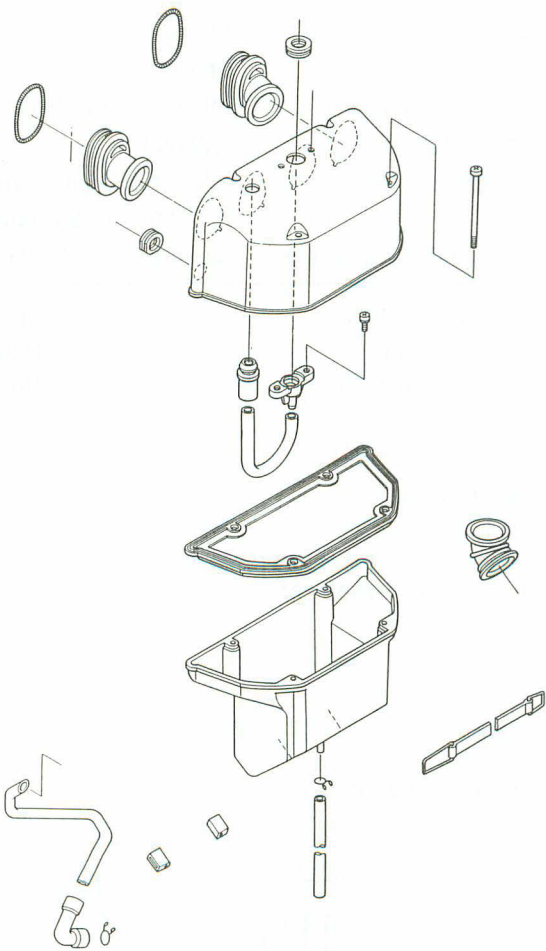
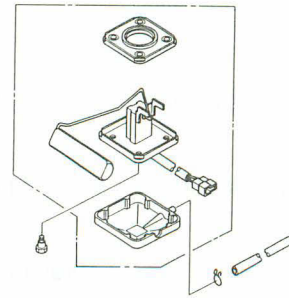
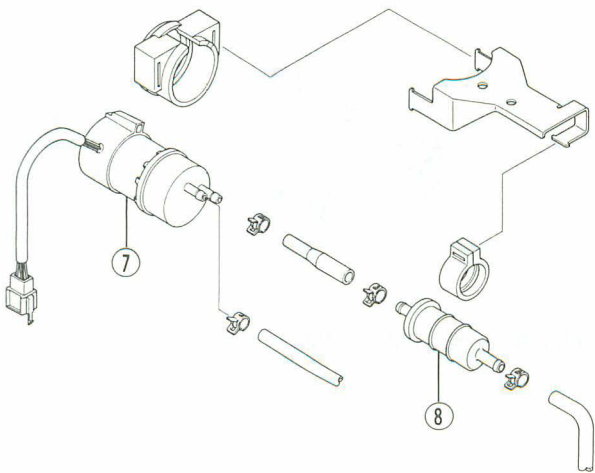

2-4 FUEL SYSTEM

Specifications

Item	ZX1000-B1	ZX1000-B2	ZX1000-B3
Throttle Grip:			
Throttle grip free play	2 – 3 mm	←	←
Choke Cable:			
Choke lever free play	2 – 3 mm	←	←
Carburetor:			
Make, type	Keihin, CVKD36	←	←
Main jet	130, (U) 130 [128], (Cal) 135 [132]	←, (F) 135	←, (E) (UK) (W) 118, (F) 122
Main air jet	100	←	←
Jet needle	N14C, (UK) N54D	←	←
Pilot jet	38 [35]	←	←
Pilot air jet	130, (S) 140	←	←
Starter jet	55, (Cal) 45	←	←
Pilot screw	2 turns out, (A) (AS) 1¼, (U) —, (S) 2½	←, (W) 1½	←
Service fuel level	5.0 mm below the mark	←	←
Float height	13.0 mm	←	←
Idle speed	950 – 1 050 r/min (rpm)	←	←
	(S) 1 150 – 1 250 r/min (rpm)	←	←
Synchronization vacuum	Less than 2.7 kPa (2 cm Hg)	←	←

(A) : Australian model
 (AS) : Austrian model
 (Cal) : Californian model

(E) : European model
 (S) : Swiss model
 (U) : US model

(UK) : UK model
 (W) : West German model
 [] : High Altitude (US model)

Special Tools

Pressure Cable Luber: K56019-021

Fuel Level Gauge: 57001-1017

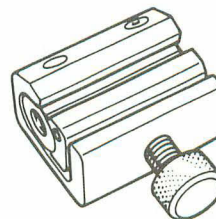
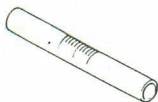

Vacuum Gauge: 57001-1198

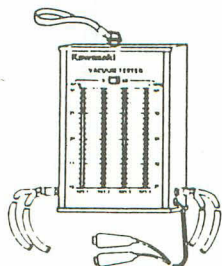

Drain Plug Wrench: 57001-1269

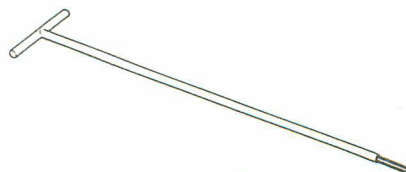

NOTE

○ The vacuum gauge & tachometer (P/N 57001-1291) can be used instead of the vacuum gauge (P/N 57001-1198).

Throttle Grip and Cables

Throttle Cable Adjustment

- Check throttle grip free play.

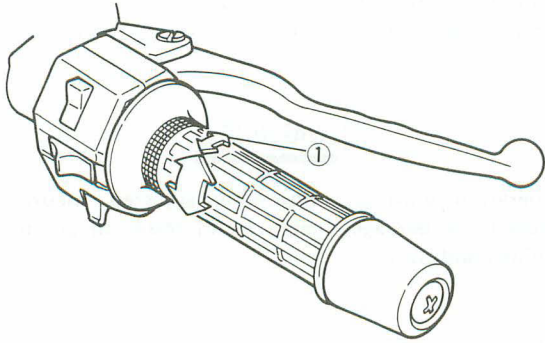

1. Throttle Grip Free Play

Throttle Grip Free Play

Standard: 2 – 3 mm

★ If the free play is incorrect, loosen the locknut and turn the adjuster of the accelerator cable until the proper amount of throttle grip play is obtained.

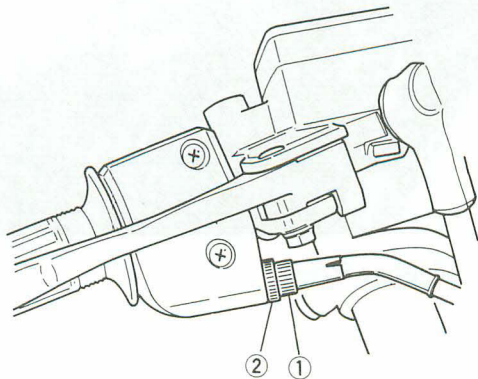

1. Adjuster

2. Locknut

- Tighten the locknut securely.
- ★ If the play can not be adjusted by using the adjuster at the throttle grip, use the adjusters at the carburetors.
- Remove the fuel tank.

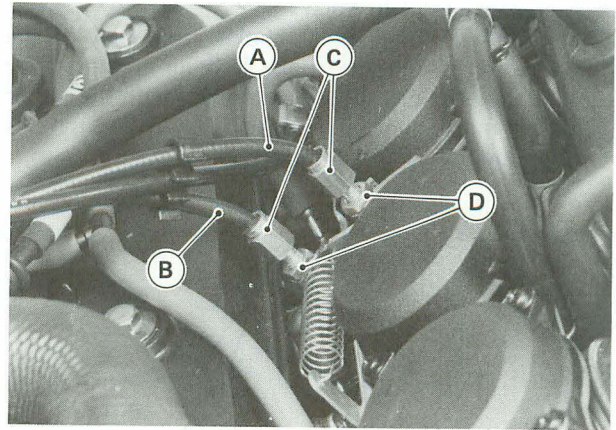

A. Accelerator Cable
B. Decelerator Cable

C. Adjusting Nuts
D. Locknuts

- Loosen the upper nuts, and turn both throttle cable adjusting nuts fully at the lower ends of the throttle cable to give the throttle grip plenty of play.
- With the throttle grip completely closed, turn the decelerator cable until the inner cable just becomes tight.
- Turn the adjusting nut of the accelerator cable adjusting nut until the correct throttle grip free play is obtained.
- Tighten the upper nut.

Choke Cable

Choke Cable Adjustment

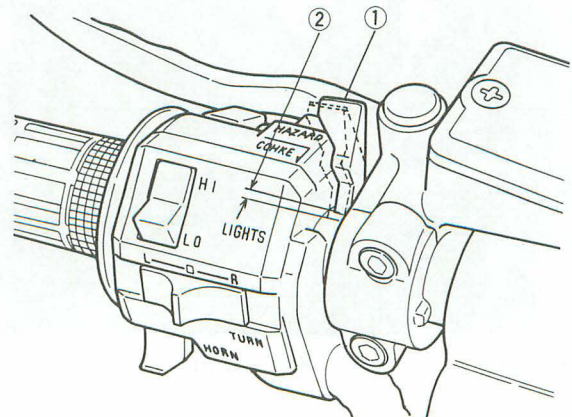

1. Choke Lever

2. Play

2-6 FUEL SYSTEM

- Check choke cable free play.
- Determine the amount of choke cable play at the choke lever. Pull the choke lever until the starter plunger lever at the carburetor contacts with the starter plunger; the amount of choke lever lower end travel is the amount of choke cable play.

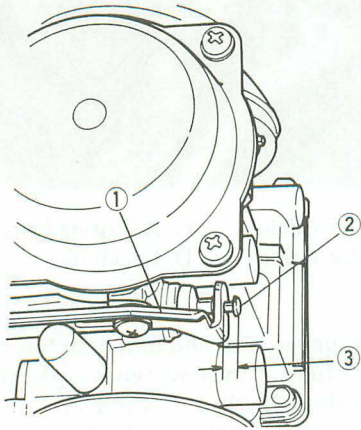

1. Starter Plunger Lever 3. Play
2. Starter Plunger

Choke Cable (Lever) Play

Standard: 2 – 3 mm

- If the play is incorrect, loosen the locknut and turn the adjuster at the middle of the cable until the proper amount of choke lever play is obtained.
- Remove the fuel tank.

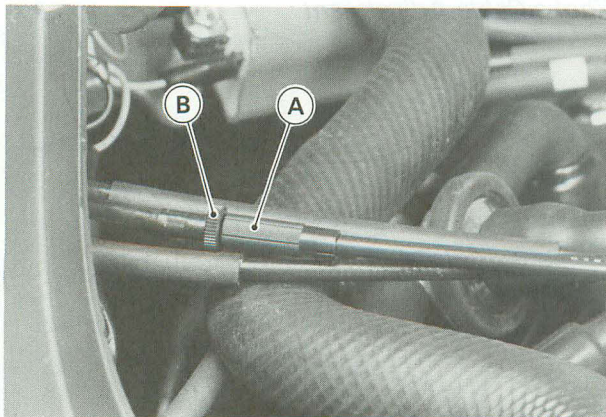

A. Adjuster B. Locknut

- Tighten the locknuts securely.

Carburetors

Idle Speed Adjustment

- Set the motorcycle on its center stand.
- Start the engine and warm it up thoroughly.
- Turn the handlebar from side to side while idling the engine.
- ★ If idle speed varies, the throttle cables may be poorly routed or they may be damaged.
- Correct any problem before operating the motorcycle.

WARNING

- Operation with an improperly adjusted, incorrectly routed, or damaged cable could result in an unsafe riding condition.

- Check idle speed.

Idle Speed

Standard: 950 – 1 050 r/min (rpm)
Ⓢ 1 150 – 1 250 r/min (rpm)

- Turn the idle adjusting screw until idle speed is correct.

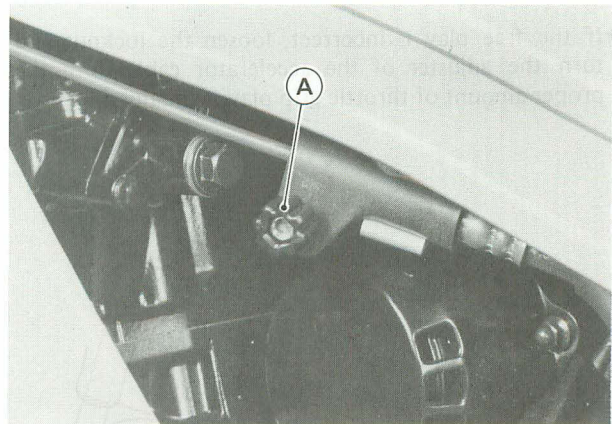

A. Idle Adjusting Screw

High Altitude Performance Adjustment (US model)

- To improve the EMISSION CONTROL PERFORMANCE of vehicles operated above **4,000 feet**, Kawasaki recommends the following Environmental Protection Agency (EPA) approved modification.
- Change the main jet and pilot jet for high altitude use.

High Altitude Carburetor Specifications

Main Jet: #128, (Cal) #132
 Pilot Jet: #35

Carburetor Synchronization

- Set the motorcycle on its center stand.
- Start the engine and warm it up thoroughly.
- Check idle speed.
- Attach the vacuum gauge (special tool: P/N 57001-1198) to the fittings on the carburetors.

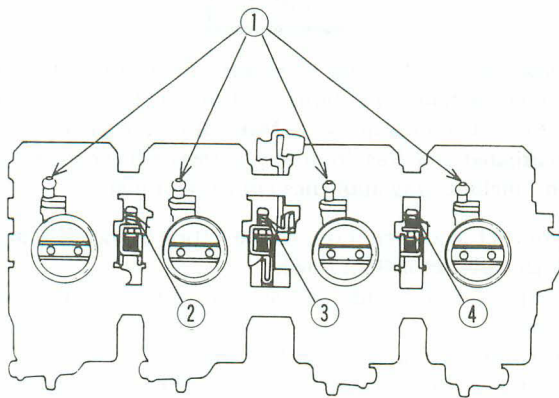

1. Fittings
2. Right Adjuster for Right Two Carburetors
3. Center Adjuster for Right and Left Pairs
4. Left Adjuster for Left Two Carburetors

- Start the engine and let it idle to measure the carburetor intake vacuum.

Carburetor Synchronization Vacuum

Standard: Less than 2.7 kPa (2 cmHg) difference between any two carburetors

- Turn the adjusting screws to synchronize the carburetors.
- First synchronize the left two and then the right two carburetors by means of the left and right adjusting screws. Then synchronize the left two carburetors and the right two carburetors using the center adjusting screw.
- ★If the carburetor synchronization cannot be obtained by using the adjusting screws, check for dirt or blockage, and then check the pilot screw settings.
- Check the carburetor synchronization again.

NOTE

○Do not turn the pilot screws carelessly during carburetors synchronization. You may cause a poor running at low engine speed.

- Check idle speed.

Service Fuel Level Adjustment

WARNING

○Gasoline is extremely flammable and can be explosive under certain conditions. Turn the ignition switch OFF. Do not smoke. Make sure the area is well ventilated and free from any source of flame or sparks; this includes any appliance with a pilot light.

- Remove the fuel tank and air cleaner box.
- Connect a fuel tank to the carburetors with a suitable hose.
- Prepare a fuel hose (6 mm in diameter and 300 mm in length).
- Connect the fuel level gauge (special tool) to the carburetor float bowl with the fuel hose.
- Check the fuel level as shown.
- Turn out the carburetor drain plug a few turns. Wait until the fuel level in the gauge settles.

NOTE

○Keeping the gauge vertical, align its "zero" line with the mark of the carburetor body right side. Then turn out the drain plug to feed fuel to the gauge.

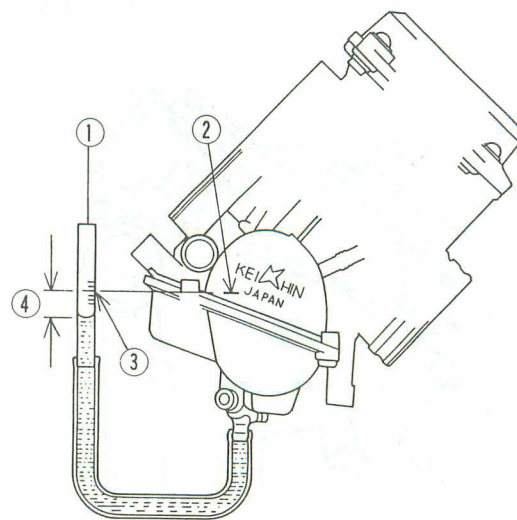

1. Fuel Level Gauge: 57001-1017
2. Mark
3. "Zero" Line
4. Fuel Level

2-8 FUEL SYSTEM

Service Fuel Level
See Specifications

- To adjust the fuel level, bend the tang on the float arm to change the float height.

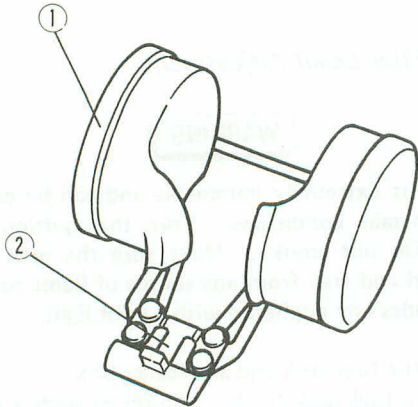

1. Float 2. Tang

- Measure the float height tilting the carburetor to touch the tang on the needle rod.
- Increasing the float height lowers the fuel level and decreasing the float height raises the fuel level.

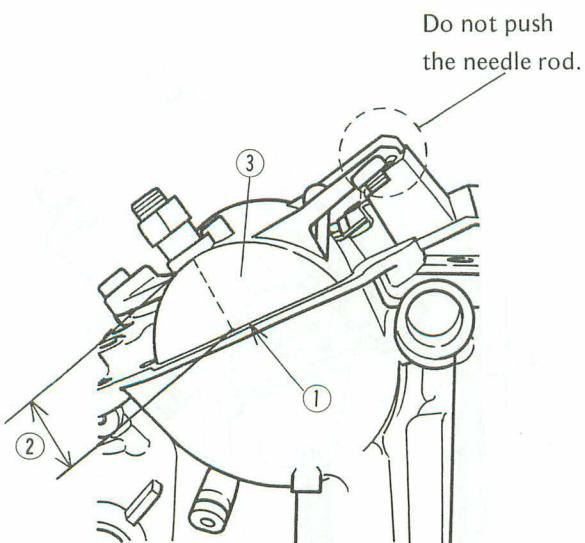

1. Bottom Edge of Carburetor Body
2. Float Height
3. Float

Float Height
Standard: 13.0 mm

NOTE

- Do not push the needle rod in during the float height measurement.

Fuel System Cleanliness Inspection

WARNING

- Gasoline is extremely flammable and can be explosive under certain conditions. Turn the ignition switch OFF. Do not smoke. Make sure the area is well ventilated and free from any source of flame or sparks; this includes any appliance with a pilot light.
- Connect a suitable hose to the fitting at the bottom of each carburetor float bowl.
- Run the lower ends of the hoses into a suitable container.
- Turn the fuel tap to the RES position.
- Turn out each drain plug a few turns with the drain plug wrench (special tool) and drain the float bowls.

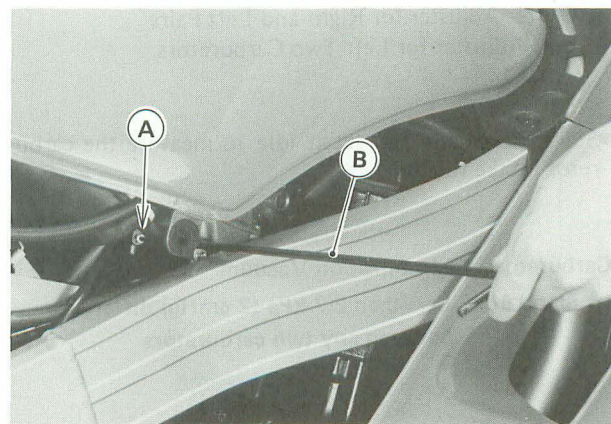

- A. Drain Plug
B. Drain Plug Wrench: 57001-1269

- Check to see if water or dirt comes out.
- Tighten the drain plugs and turn the fuel tap to OFF position.
- ★ If any water or dirt appeared during the above inspection, clean the fuel system.

Carburetor Disassembly/Assembly

WARNING

Gasoline is extremely flammable and can be explosive under certain conditions. Turn the ignition switch OFF. Do not smoke. Make sure the area is well ventilated and free from any source of flame or sparks; this includes any appliance with a pilot light.

CAUTION

During carburetor disassembly, be careful not to damage the diaphragm. Never use a sharp edge to remove the diaphragm.

- For the US model, remove the pilot screw plug as follows:
 - Punch a hole in the plug and pry it at with an awl or other suitable tool.
 - Turn in the pilot screw and count the number of turns until it seats fully but not tightly, and then remove the screw. This is to set the screw to its original position when assembling.
 - Turn in the pilot screw fully but not tightly, and then back it out the same number of turns counted during disassembly.
- For the US model, install the pilot screw plug as follows:
 - Install a new plug in the pilot screw hole, and apply a small amount of a bonding agent to the circumference of the plug to fix the plug.

CAUTION

Do not apply too much bonding agent to the plug or the pilot screw itself may be fixed.

Plug installation (US model only)

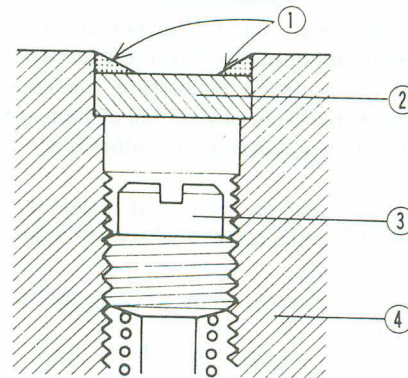

- 1. Apply bonding agent.
- 2. Plug
- 3. Pilot Screw
- 4. Carburetor Body

Turn the carburetor body upside-down, and drop the needle jet into place so that the smaller diameter end of the jet goes in first.

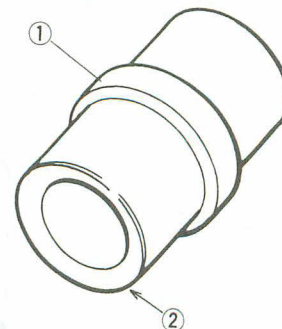

- 1. Needle Jet
- 2. Small End

CAUTION

Do not force the needle jet holder (air bleed pipe) and main jet or overtighten them. They could be damaged requiring replacement.

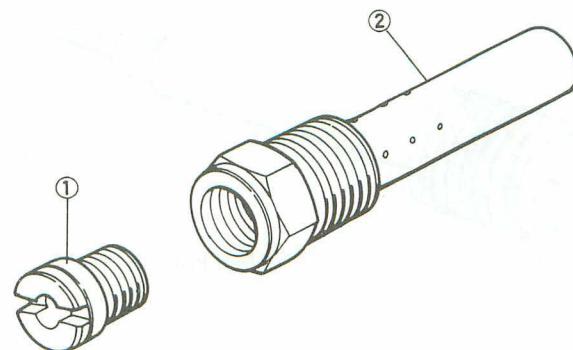

- 1. Main Jet
- 2. Needle Jet Holder

2-10 FUEL SYSTEM

Carburetor Inspection

WARNING

- Gasoline is extremely flammable and can be explosive under certain conditions. Turn the ignition switch OFF. Do not smoke. Make sure the area is well ventilated and free from any source of flame or sparks; this includes any appliance with a pilot light.
- Slide the starter plunger lever right to left it to check that the starter plungers move smoothly and return with spring tension.
- ★ If the starter plungers do not work properly, replace the carburetors.
- Turn the throttle cable pulley to check that the throttle butterfly valves move smoothly and return by spring tension.
- ★ If the throttle valves do not more smoothly. Replace the carburetors.
- Check that the O-rings on the float bowl and drain plug and the diaphragm on the vacuum piston are in good condition.
- ★ If any of the O-rings or diaphragms are not in good condition, replace them.
- Check the plastic tip of the float valve needle. It should be smooth, without any grooves, scratches, or tears.

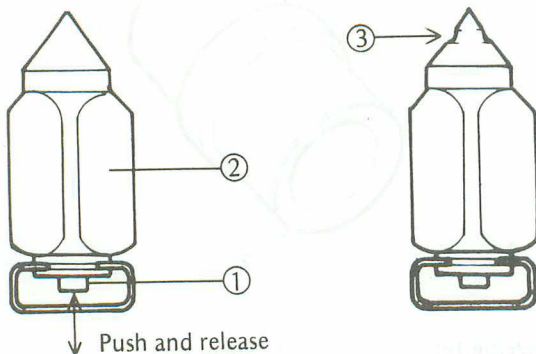

1. Rod 3. Valve Needle Wear
2. Valve Needle

- ★ If the plastic tip is damaged, replace the needle.
- Check the tapered portion of the pilot screw for wear or damage.

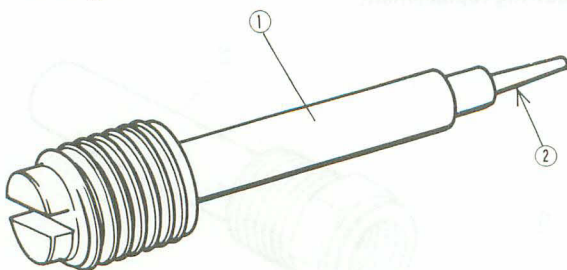

1. Pilot Screw 2. Tapered Portion

- ★ If the pilot screw is worn or damaged on the tapered portion, it will prevent the engine from idling smoothly, Replace it.

Fuel Pump and Filter

WARNING

- Gasoline is extremely flammable and can be explosive under certain conditions. Turn the ignition switch OFF. Do not smoke. Make sure the area is well ventilated and free from any source of flame or sparks; this includes any appliance with a pilot light.
- Be prepared for fuel spillage.

Removal

- Remove the following.
 - Fuel Tank
 - Air Cleaner Housing
 - Carburetor
- Disconnect the pump lead connector.

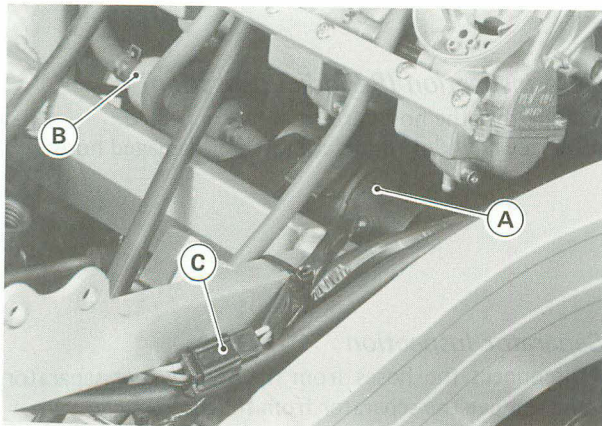

A. Fuel Pump C. Connector
 B. Fuel Filter

- Remove the fuel pump and filter.

Installation

- Installation is the reverse of removal. Note the following.
- Connect the fuel hoses as shown.

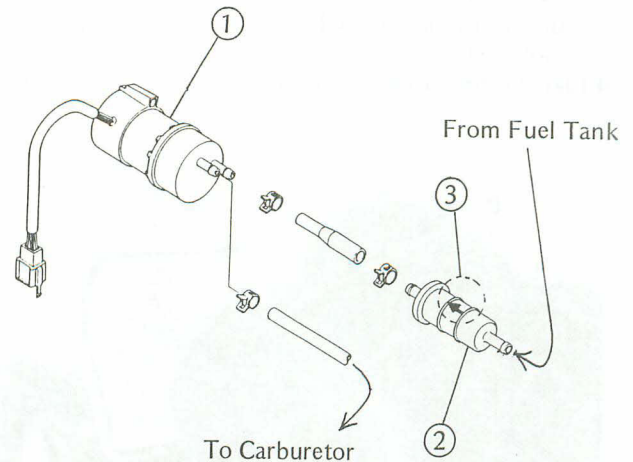

1. Fuel Pump 3. Arrow
 2. Fuel Filter

- Install the fuel filter so that the arrow on it shows the fuel flow from the fuel tank to the fuel pump.
- Be sure to route the hoses so they will not be kinked or stretched.

Inspection

Refer to the Electrical System chapter.

Air Cleaner

Element Cleaning

WARNING

- Clean the element in a well-ventilated area, and take care that there is no spark or flame anywhere near the working area; this includes any appliance with a pilot light. Because of the danger of highly flammable liquids, do not use gasoline or low flash-point solvents to clean the element. A fire or explosion could result.

2-12 FUEL SYSTEM

- Remove the following.
 - Fuel Tank
 - Air Cleaner Housing Bolts
 - Rubber Strap
- Take out the air cleaner element.

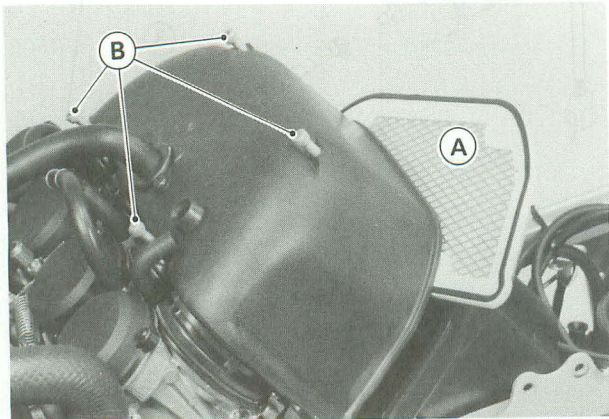

A. Air Cleaner Element B. Bolts

WARNING

- If dirt or dust is allowed to pass through into the carburetors, the throttle may become stuck, possibly causing accident.
- Wash the element in a bath of high flash-point solvent and then dry it with compressed air or by shaking it.
- After cleaning, saturate a clean, lint-free towel with SE class SAE 30 oil and apply the oil to the element by tapping the foam side of the element with the towel.

Evaporative Emission Control System (US California Vehicle only)

The Evaporative Emission Control System routes fuel vapors from the fuel system into the running engine or stores the vapors in a canister when the engine is stopped. Although no adjustments are required, a thorough visual inspection must be made at the intervals specified by the Periodic Maintenance Chart.

Parts Removal/Installation Notes

WARNING

- Gasoline is extremely flammable and can be explosive under certain conditions. Turn the ignition switch OFF. Do not smoke. Make sure the area is well ventilated and free from any source of flame or sparks; this includes any appliance with a pilot light.

CAUTION

- If gasoline, solvent, water or any other liquid enters the canister, the canister's vapor absorbing capacity is greatly reduced. If the canister does become contaminated replace it with a new one.
- To prevent the gasoline from flowing into the canister or from flowing out of the canister, hold the separator perpendicular to the ground.
- Connect the hoses according to the diagram of the system. Make sure they do not get pinched or kinked.

Hose Inspection (Periodic Inspection)

- Check that the hoses are securely connected.
- Replace any kinked, deteriorated or damaged hoses.

Separator Inspection

- Disconnect the hoses from the liquid/vapor separator, and remove the separator from the motorcycle.
- Visually inspect the separator for cracks and other damage.
- ★ If the separator has any cracks or is badly damaged, replace it with a new one.

Separator Operation Test

WARNING

- Gasoline is extremely flammable and can be explosive under certain conditions. Turn the ignition switch OFF. Do not smoke. Make sure the area is well ventilated and free from any source of flame or spark; this includes any appliance with a pilot light.

- Connect the hoses to the separator, and install the separator on the motorcycle.
- Disconnect the breather hose from the separator, and inject about 20 mL of gasoline into the separator through the hose fitting.
- Disconnect the fuel return hose from the fuel tank.
- Run the open end of the return hose in to the container level with the tank top.
- Start the engine, and let it idle.
- ★ If the gasoline in the separator comes out of the hose, the separator works well. If it does not, replace the separator with a new one.

Canister Inspection

- ★ If the canister has any crack or bad damage, replace it with a new one.

NOTE

- The canister is designed to work well through the motorcycle's life without any maintenance if it is used under normal conditions.

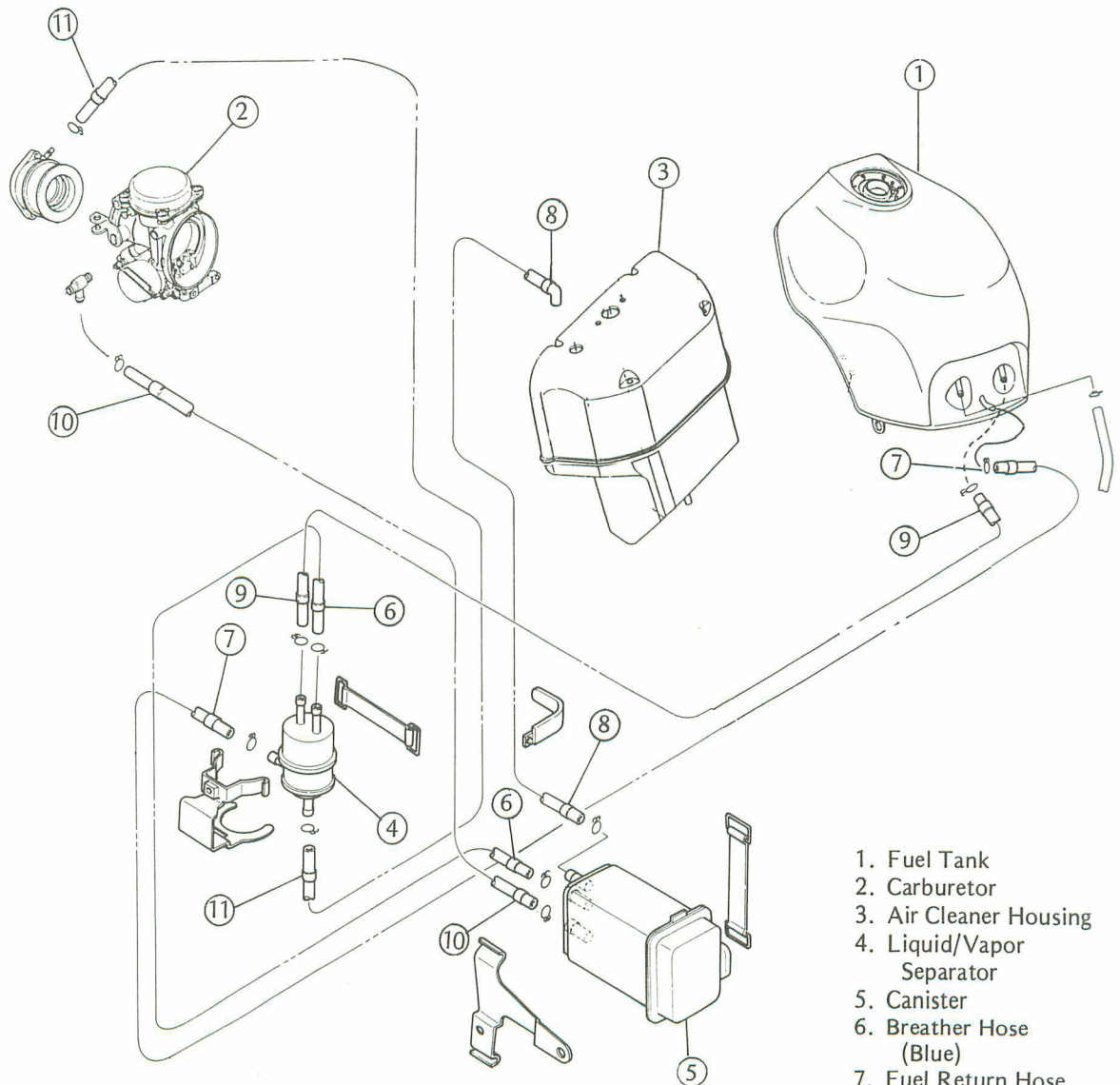

1. Fuel Tank
2. Carburetor
3. Air Cleaner Housing
4. Liquid/Vapor Separator
5. Canister
6. Breather Hose (Blue)
7. Fuel Return Hose (Red)
8. Purge Hose (Green)
9. Breather Hose (Blue)
10. Breather Hose (Yellow)
11. Vacuum Hose (White)

Cooling System

Table of Contents

3

Exploded View	3-2
Specifications	3-3
Coolant Flow Chart.....	3-3
Coolant	3-4
Coolant Level Inspection.....	3-4
Coolant Draining.....	3-4
Coolant Filling	3-5
Pressure Testing.....	3-5
Water Pump.....	3-6
Removal	3-6
Installation	3-6
Water Pump Inspection.....	3-6
Radiator and Radiator Fan	3-7
Removal	3-7
Radiator Inspection.....	3-8
Radiator Cap Inspection	3-8
Thermostat	3-9
Removal	3-9
Installation	3-9
Inspection.....	3-9
Thermostatic Fan Switch, Water Temperature Sensor.....	3-10

3-2 COOLING SYSTEM

Exploded View

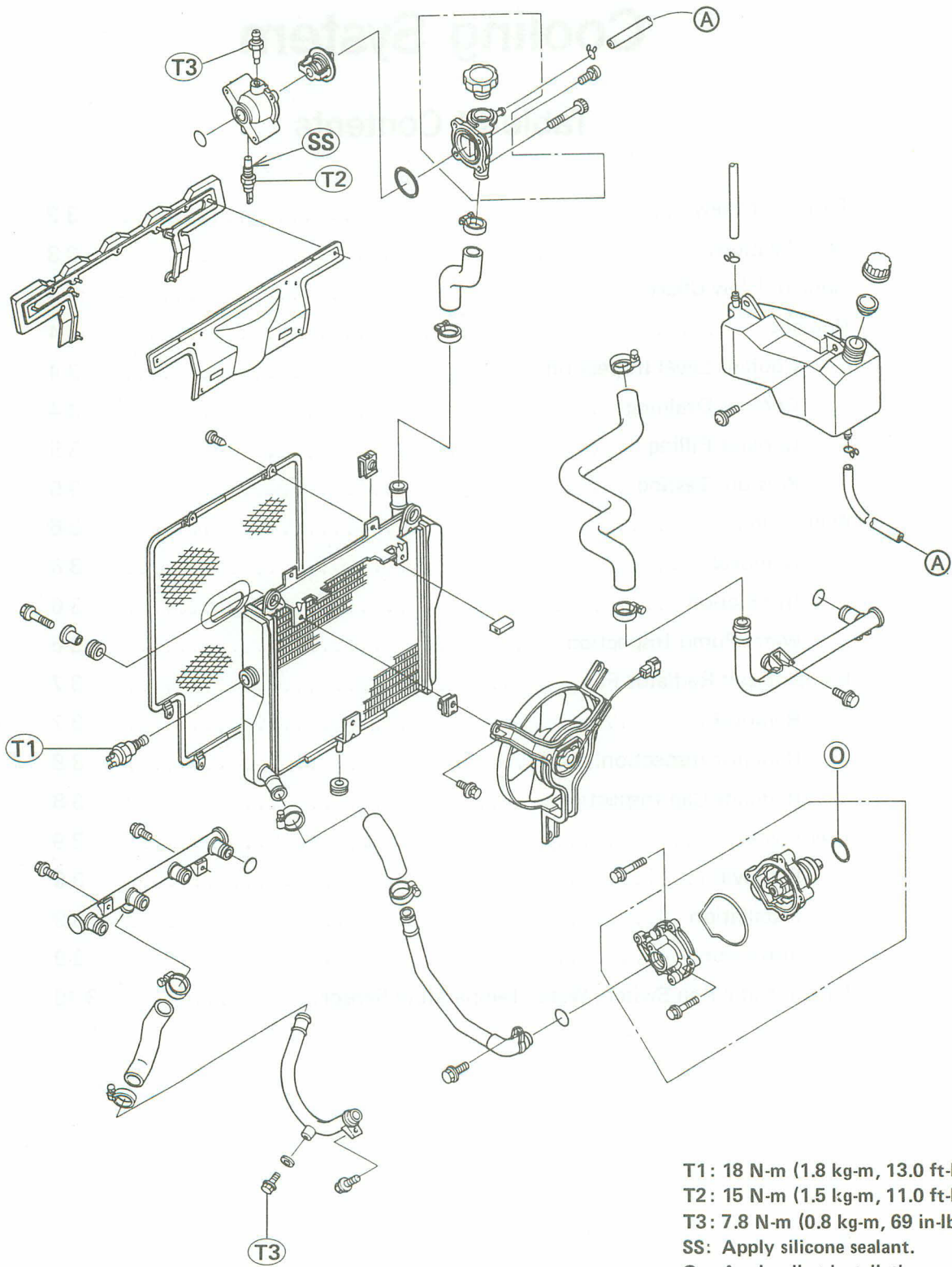

Specifications

Item	Standard
Coolant: Type Mixed ratio Freezing point Total amount	Permanent type of antifreeze (soft water and ethylene glycol plus corrosion and rust inhibitor chemicals for aluminum engines and radiators) Soft water 50%, coolant 50% -35°C (-31°F) 3.1 L
Radiator: Radiator cap relief pressure	93 – 123 kPa (0.95 – 1.25 kg/cm ² , 14 – 18 psi)
Thermostat: Valve opening temperature Valve full opening lift	80 – 84°C (176 – 183°F), (UK) 69 – 73°C (156 – 163°F) More than 8 mm @95°C (203°F)

(UK): UK model (ZX1000-B1 only)

Coolant Flow Chart

When the engine is cold, the thermostat is closed, so that the coolant flow restricted through the small hole on the thermostat (air hole), causing the engine to warm up more quickly.

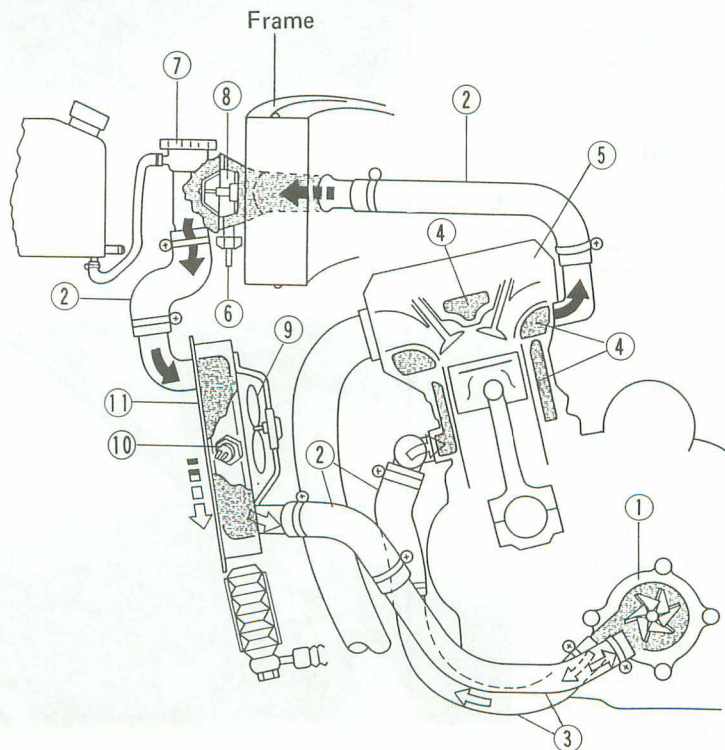

1. Water Pump
2. Water Hose
3. Water Pipe
4. Water Jacket
5. Cylinder Head
6. Water Temperature Sensor
7. Radiator Cap
8. Thermostat
9. Radiator Fan
10. Cooling Fan Switch
11. Radiator

3-4 COOLING SYSTEM

Coolant

Coolant Level Inspection

NOTE

○Check the level when the engine is cold (room or ambient temperature).

- Check the coolant level in the reservoir tank with the motorcycle held perpendicularly.
- ★If the coolant level is lower than the “L” mark, add coolant to the “U” mark.

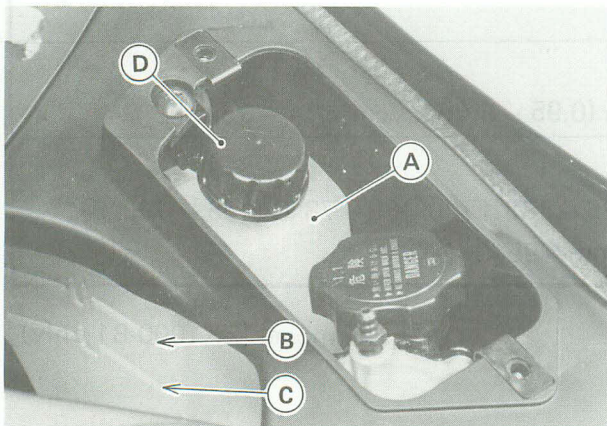

A. Reservoir Tank C. “L” Mark
B. “U” Mark D. Tank Cap

CAUTION

- For refilling, add the specified mixture of coolant and soft water. Adding water alone dilutes the coolant and degrades its anticorrosion properties.
- The diluted coolant can attack the aluminum engine parts. In an emergency, soft water can be added. But the diluted coolant must be returned to the correct mixture ratio within a few days.
- If coolant must be added often, or the reservoir tank has run completely dry; there is probably leakage in the cooling system. Check the system for leaks.

Coolant Draining

WARNING

- To avoid burns, do not remove the radiator cap or try to change the coolant when the engine is still hot. Wait until it cools down.
- Coolant on tires will make them slippery and can cause an accident and injury. Immediately wipe up or wash away any coolant that spills on the frame, engine, or other painted parts.
- Since coolant is harmful to the human body, do not use for drinking.

- Remove the following.
 - Lower Fairing
 - Right Side Middle Fairing
 - Radiator Cap

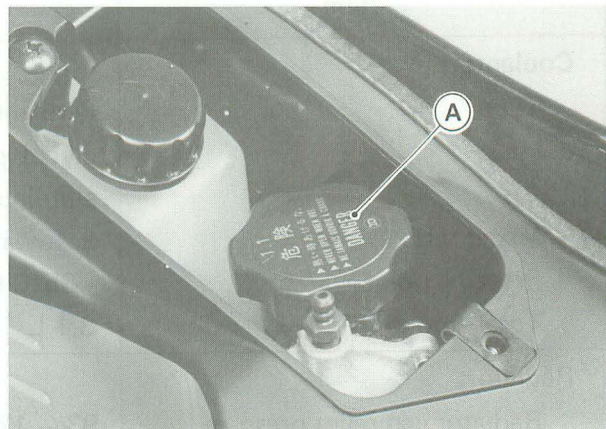

A. Radiator Cap

Drain Plug (bottom of water pipe)

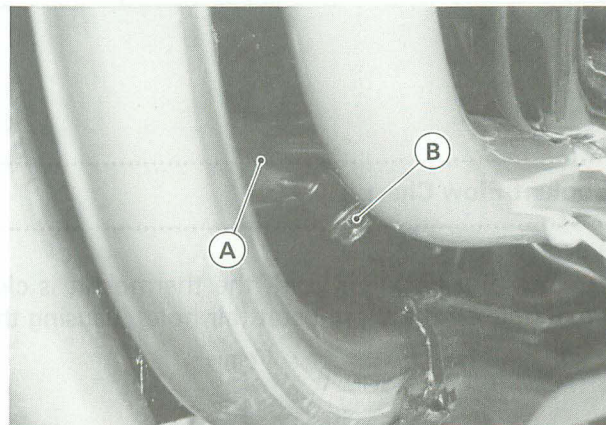

A. Water Pipe B. Drain Bolt

- Drain the coolant from the radiator.
- Pull off the reservoir tank hose and pour the coolant into a container.

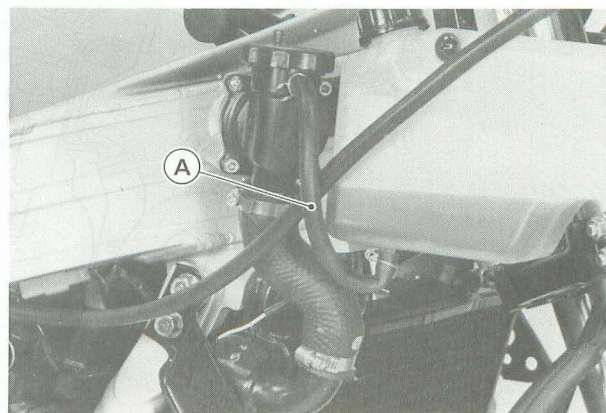

A. Reservoir Tank Hose

Coolant Filling

- Tighten the drain plug to the specified torque (see Exploded View).
- Fill the radiator up to the thermostat housing filler neck with coolant, and install the radiator cap.

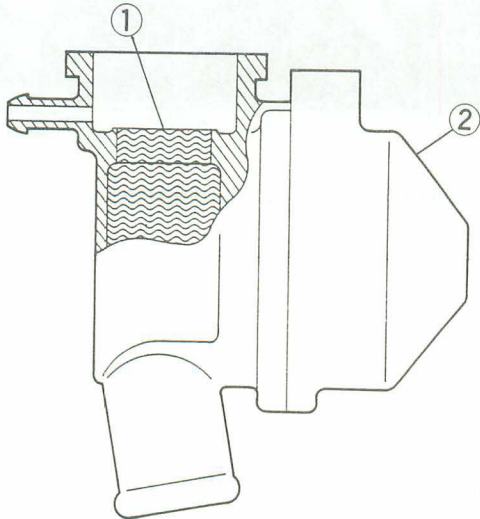

1. Coolant Level
2. Thermostat Housing

NOTE

○ Pour in the coolant slowly so that it can expel the air from the engine and radiator.

- Fill the reservoir tank up to the "U" mark with coolant, and install the cap.

CAUTION

- Soft or distilled water must be used with the antifreeze (see below for antifreeze) in the cooling system.
- If hard water is used in the system, it causes scales accumulation in the water passages, and considerably reduces the efficiency of the cooling system.

Water and Coolant Mixture Ratio (Recommended)

Soft Water	:	50%
Coolant	:	50%
Freezing Point	:	-35°C (-31°F)

NOTE

○ Choose a suitable mixture ratio by referring to the coolant manufacturer's directions.

- Loosen the air bleeder bolt, until the coolant begins to slow out the air bleeder bolt hole (that is, when all the remaining air has been forced out).
- Tighten the air bleeder bolt.

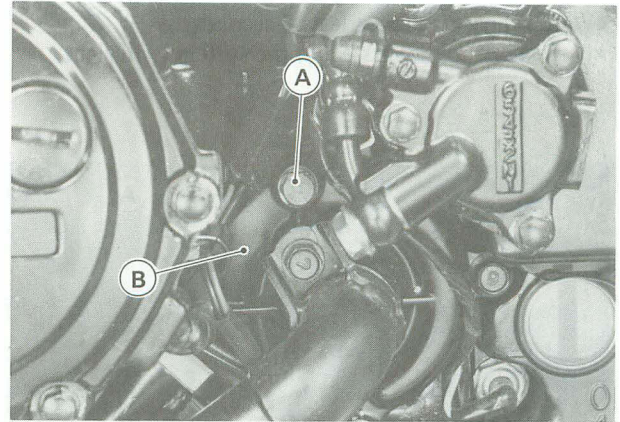

A. Air Bleeder Bolt B. Water Pump Cover

- Start the engine, warm it up thoroughly until the radiator fan turns on and then stop the engine.
- Check the coolant level in the reservoir tank after the engine cools down.
- ★ If the coolant level is lower than the "L" mark, add coolant to the "U" mark.

CAUTION

○ Do not add more coolant above the "U" mark.

Pressure Testing

- Remove the radiator cap, and install a cooling system pressure tester on the radiator filler neck.

NOTE

○ Wet the cap sealing surfaces with water or coolant to prevent pressure leaks.

3-6 COOLING SYSTEM

- Build up pressure in the system carefully until the pressure reaches 123 kPa (1.25 kg/cm², 18 psi).

CAUTION

- During pressure testing, do not exceed the pressure for which the system is designed. The maximum pressure is 123 kPa (1.25 kg/cm², 18 psi).

- Watch the gauge for at least 6 seconds.
- ★If the pressure holds steady, the system is all right.

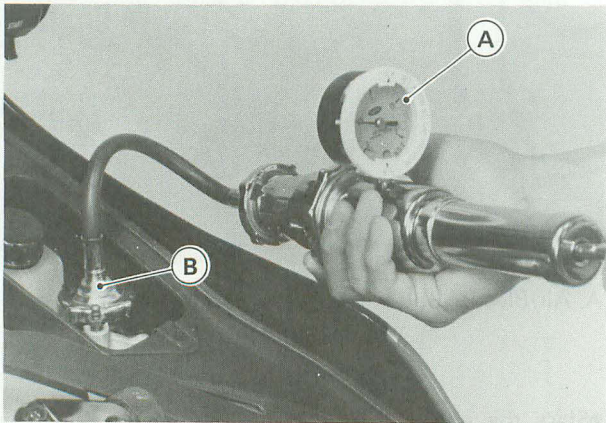

A. Pressure Tester
B. Adapter

- ★If the pressure drops soon, check for leaks.

Water Pump

Removal

- Drain the coolant.
- Remove the following.
 - Clutch Slave Cylinder (see Clutch chapter)
 - Engine Sprocket Cover
 - Water Pipes
- Unscrew the water pump mounting bolts (2), and pull out the water pump.

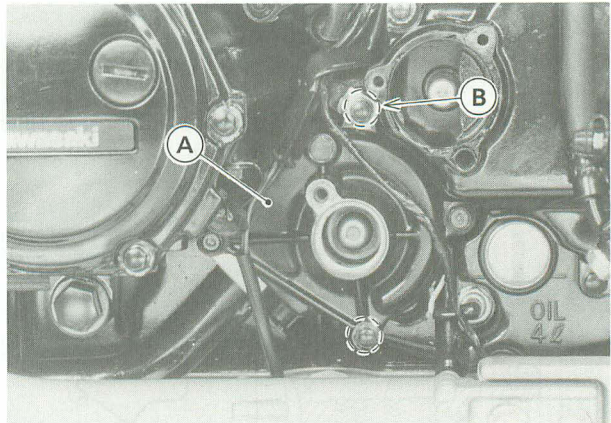

A. Water Pump B. Mounting Bolts

Installation

- Note the position of the oil pump shaft projection and turn the water pump shaft so that the projection fits into the slot.

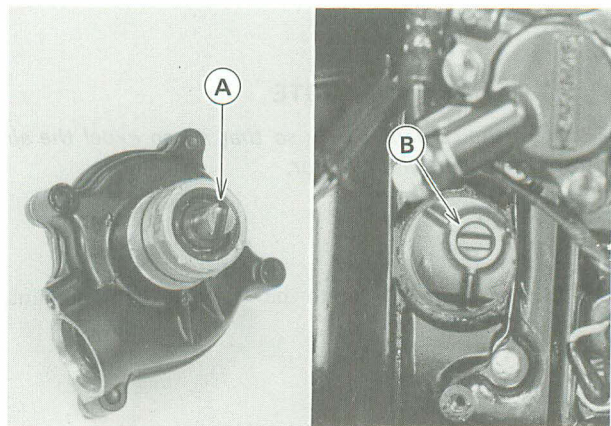

A. Water Pump Shaft B. Oil Pump Shaft

Water Pump Inspection

- Check the drainage outlet passage at the bottom of the water pump body for coolant leaks.
- ★If the mechanical seal is damaged, the coolant leaks through the seal and drains through the passage. Replace the water pump unit.

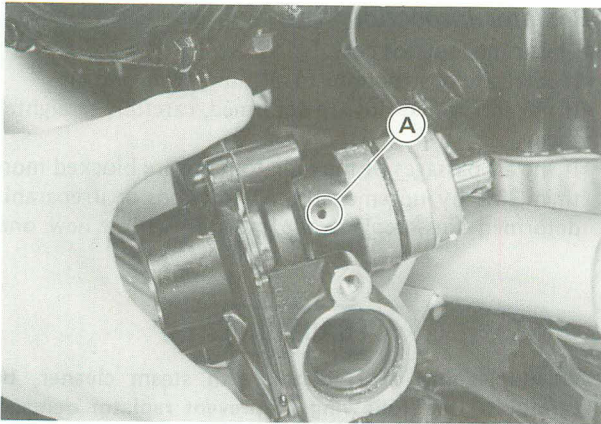

A. Drainage Outlet Passage
(at the bottom of the pump body)

- Visually check the impeller.
- ★If the surface is corroded, or if the blades are damaged, replace the water pump unit.

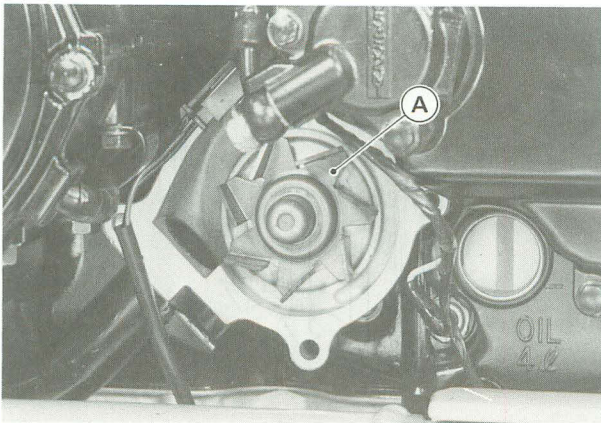

A. Impeller

- Remove the following.
 - Fuel Tank
 - Fairings
 - Coolant (Drain)
 - Horns
 - Radiator Fan Connector

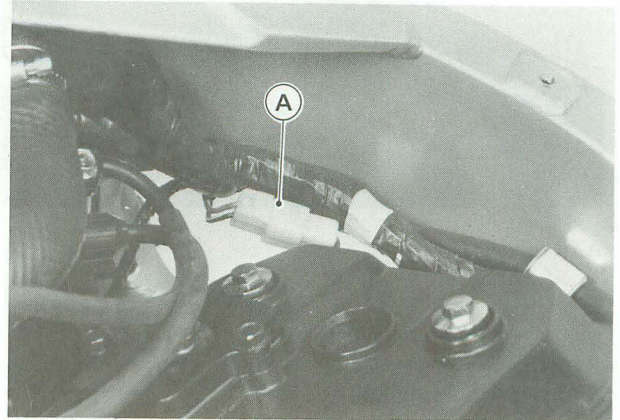

A. Radiator Fan Connector

Fan Switch Leads

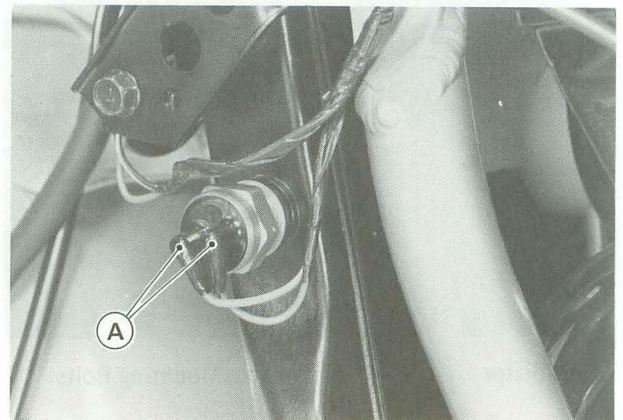

A. Fan Switch Leads

Radiator Hoses

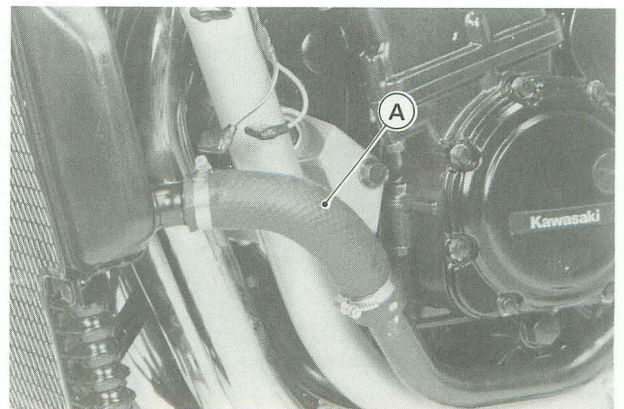

A. Radiator Hose

Radiator and Radiator Fan

Removal

WARNING

- The radiator fan is connected directly to the battery. The radiator fan may start even if the ignition switch is off. NEVER TOUCH THE RADIATOR FAN UNTIL THE RADIATOR FAN CONNECTOR IS DISCONNECTED. TOUCHING THE FAN BEFORE THE CONNECTOR IS DISCONNECTED COULD CAUSE INJURY FROM THE FAN BLADES.

- Install the cap on a cooling system pressure tester.

NOTE

- Wet the cap sealing surfaces with water or coolant to prevent pressure leaks.

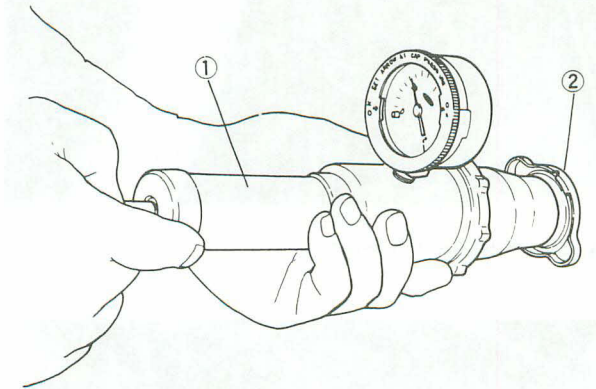

1. Pressure Tester 2. Radiator Cap

- Watching the pressure gauge, pump the pressure tester to build up the pressure. The cap must retain the pressure at least 6 seconds. Also the cap must open at the pressure shown in the table.

Radiator Cap Relief Pressure

Standard: 93 – 123 kPa
(0.95 – 1.25 kg/cm², 14 – 18 psi)

- ★ If the cap cannot hold the specified pressure, or if it holds too much pressure, replace it with a new one.

.....
Thermostat
.....

Removal

- Remove the following
 - Fuel Tank
 - Fairings
 - Coolant (drain)
 - Reservoir Tank Hose
 - Sensor Connector
 - Radiator Hose

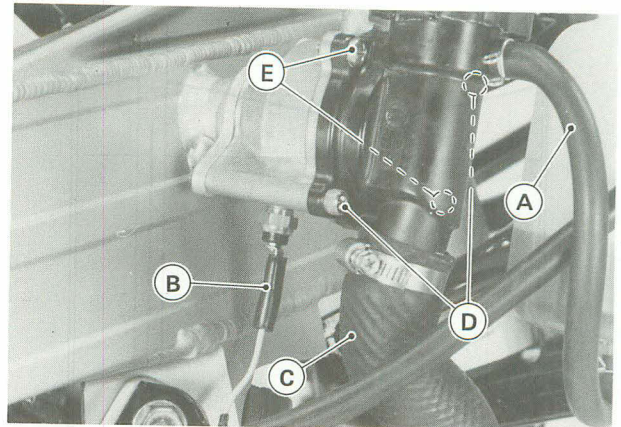

A. Reservoir Tank Hose D. Mounting Bolts
B. Sensor Connector E. Housing Screws
C. Radiator Hose

- Unscrew the housing screws remove the thermostat.

Installation

- Install the thermostat noting the following.
 - Install the thermostat in the housing so that the air hole is on top.

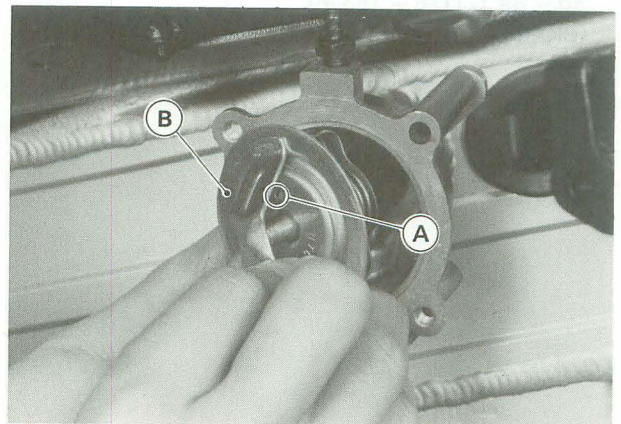

A. Air Hole B. Thermostat

- Be sure to install the O-ring to the housing.
- Fill the radiator with coolant.

Inspection

- Remove the thermostat, and inspect the thermostat valve at room temperature.
 - ★ If the valve is open, replace the valve with a new one.
- To check valve opening temperature, suspend the thermostat in a container of water and raise the temperature of the water.

3-10 COOLING SYSTEM

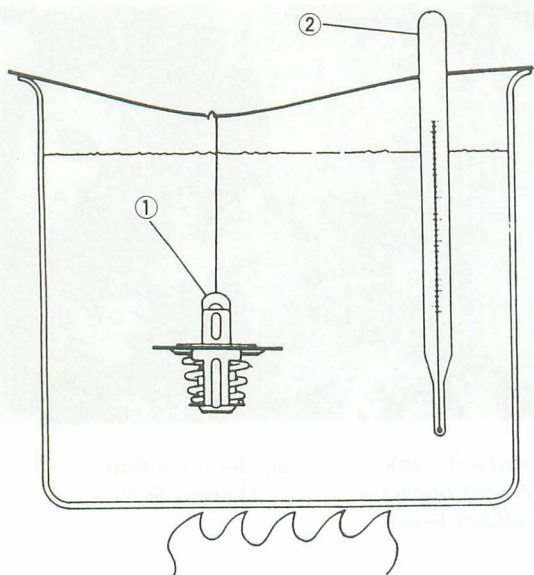

1. Thermostat

2. Thermometer

★If the measurement is out of the service limit range, replace the thermostat.

Thermostat Valve Opening Temperature

80 – 84°C (176 – 183°F)

UK 69 – 73°C (156 – 163°F)

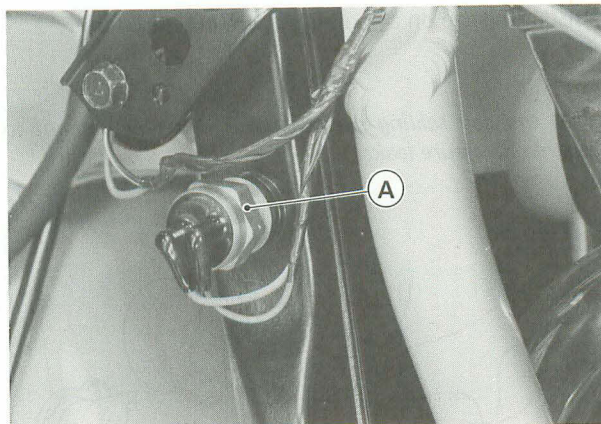

A. Thermostatic Fan Switch

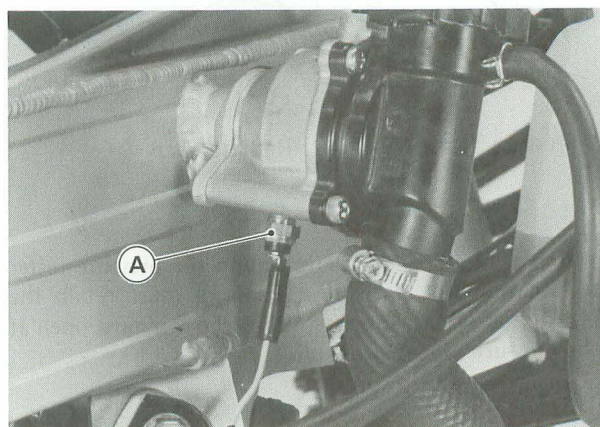

A. Water Temperature Sensor

●Refer to the Electrical System chapter for these inspection.

Thermostatic Fan Switch Water Temperature Sensor

CAUTION

○The fan switch or the water temperature sensor should never be allowed to fall on a hard surface. Such a shock to these parts can damage them.

Engine Top End

Table of Contents

4

Exploded View	4-2	Valve Face Contact Inspection	4-18
Specifications	4-4	Valve Seat Outside Diameter	4-18
Special Tools	4-6	Valve Seat Width Inspection	4-18
Clean Air System (US model)	4-7	Valve Seat Repair (Valve Lapping)	4-19
Air Suction Valve Inspection	4-7	Measuring Valve-to-Guide Clearance	
Vacuum Switch Valve Test	4-7	(Wobble Method)	4-20
Cylinder Head Cover	4-8	Cylinder, Pistons	4-21
Removal	4-8	Cylinder Removal	4-21
Installation	4-8	Cylinder Installation	4-21
Camshaft Chain Tensioner	4-8	Piston Removal	4-21
Removal	4-8	Piston Installation	4-21
Installation	4-8	Cylinder Wear	4-22
Camshaft, Camshaft Chain, Rocker Shaft	4-9	Piston Wear	4-22
Camshaft, Rocker Shaft Removal	4-9	Piston Ring, Ring Groove Wear	4-23
Camshaft, Rocker Shaft Installation	4-10	Piston Ring End Gap	4-23
Chain Timing Procedure	4-11	Carburetor Holder	4-23
Camshaft and Sprocket Assembly	4-11	Carburetor Holder Installation	4-23
Camshaft, Camshaft Cap Wear	4-11	Muffler	4-24
Camshaft Chain Wear	4-12	Removal	4-24
Cylinder Head	4-12		
Cylinder Compression Measurement	4-12		
Removal	4-12		
Installation	4-13		
Valves	4-14		
Valve Clearance Adjustment	4-14		
Valve Removal	4-17		
Valve Installation	4-17		
Valve Guide Removal	4-17		
Valve Guide Installation	4-18		

4-2 ENGINE TOP END

Exploded View

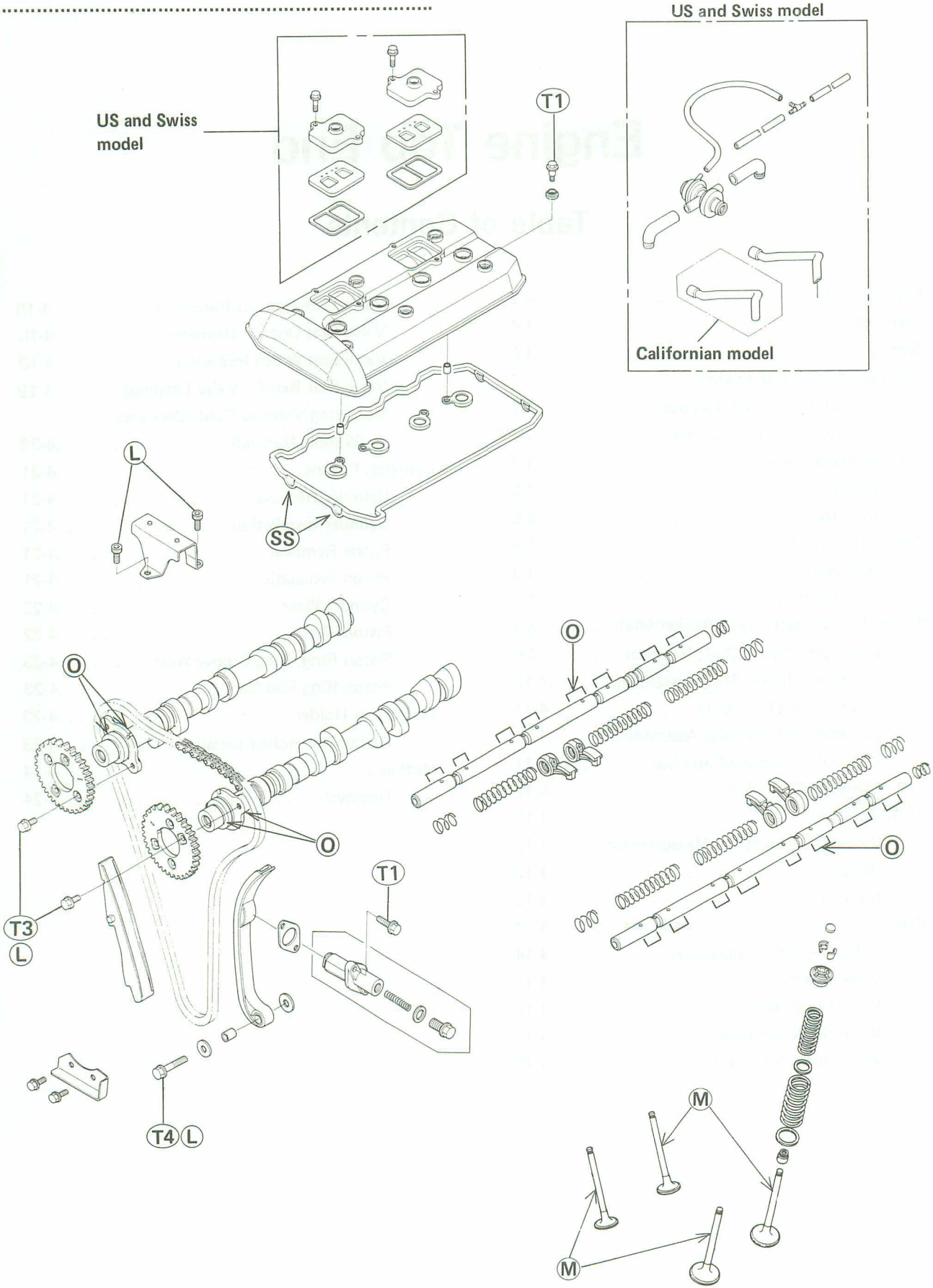

ENGINE TOP END 4-3

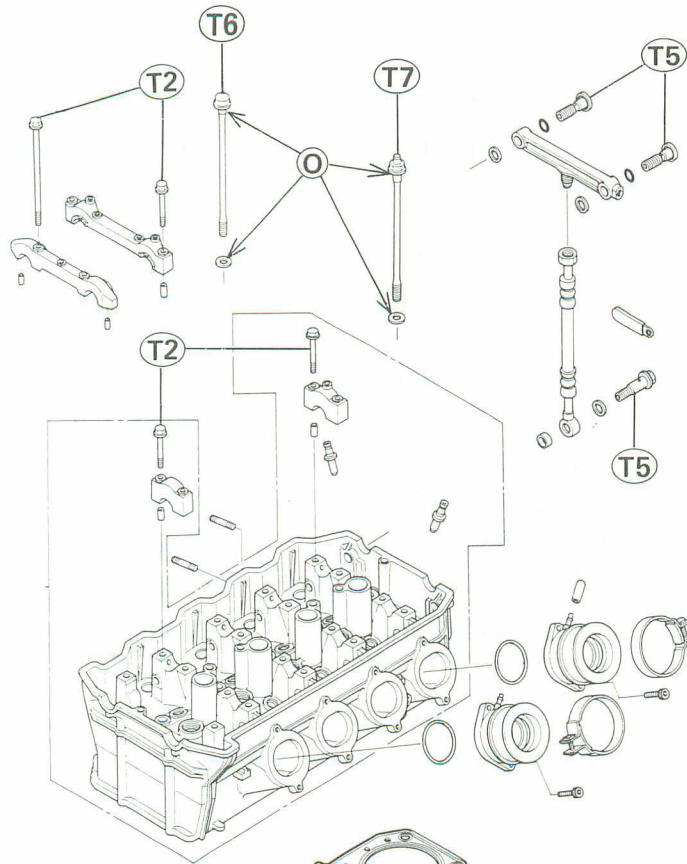

T1 : 9.8 N-m (1.0 kg-m, 87 in-lb)

T2 : 12 N-m (1.2 kg-m, 104 in-lb)

T3 : 15 N-m (1.5 kg-m, 11.0 ft-lb)

T4 : 20 N-m (2.0 kg-m, 14.5 ft-lb)

T5 : 25 N-m (2.5 kg-m, 18.0 ft-lb)

T6 : 39 N-m (4.0 kg-m, 29 ft-lb)

T7 : 51 N-m (5.2 kg-m, 38 ft-lb)

L : Apply a non-permanent locking agent.

M : Apply molybdenum disulfide grease.

SS : Apply silicone sealant.

O : Apply engine oil.

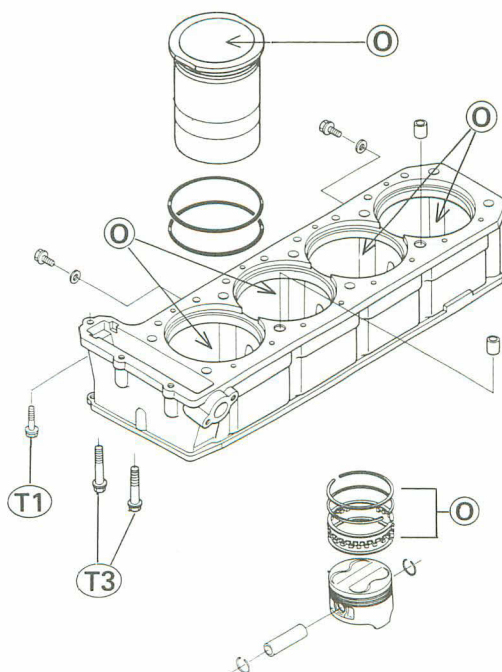
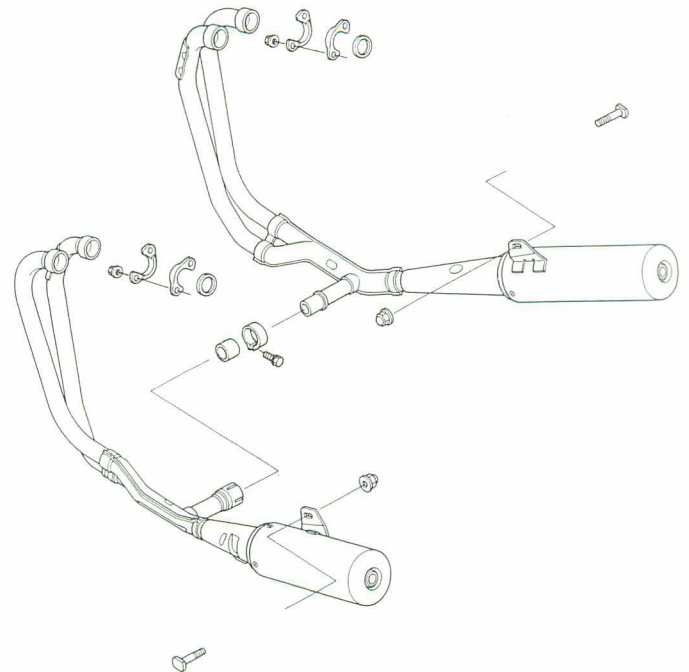
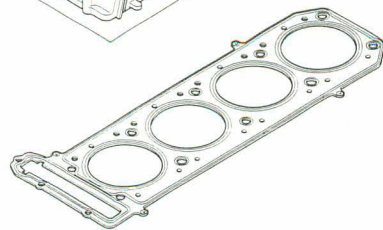

4-4 ENGINE TOP END

Specifications

Item	Standard	Service Limit
Cylinder Head, Valves:		
Valve clearance:		
Inlet	0.13 – 0.19 mm	---
Exhaust	0.18 – 0.24 mm	---
Cylinder head warp	---	0.05 mm
Valve head thickness		
Inlet	0.5 mm	0.25 mm
Exhaust	0.8 mm	0.5 mm
Valve stem bend	Less than 0.01 mm TIR	0.05 mm TIR
Valve stem diameter:		
Inlet	4.975 – 4.990 mm	4.96 mm
Exhaust	4.955 – 4.970 mm	4.94 mm
Valve guide inside diameter:		
Inlet	5.000 – 5.012 mm	5.08 mm
Exhaust	5.000 – 5.012 mm	5.08 mm
Valve/valve guide clearance (wobble method):		
Inlet	0.02 – 0.07 mm	0.18 mm
Exhaust	0.06 – 0.11 mm	0.21 mm
Valve seating surface:		
Outside diameter		
Inlet	29.3 – 29.5 mm	---
Exhaust	25.3 – 25.5 mm	---
Width		
Inlet	0.5 – 1.0 mm	---
Exhaust	0.5 – 1.0 mm	---
Valve spring free length:		
Inner	35.5 mm	33.6 mm
Outer	40.5 mm	38.6 mm
Valve seat cutting angle:		
Inlet, Exhaust	32°, 45°, 60°	---
Clean Air Sustum:		
Vacuum switch valve closing pressure:		
Open → Close	54 – 68 kPa (410 – 510 mmHg)	---

Valve Head

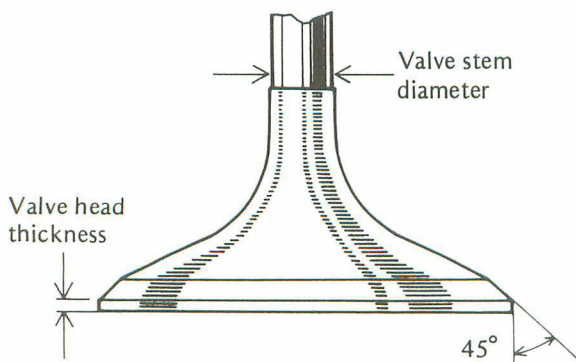

Valve Stem Bend

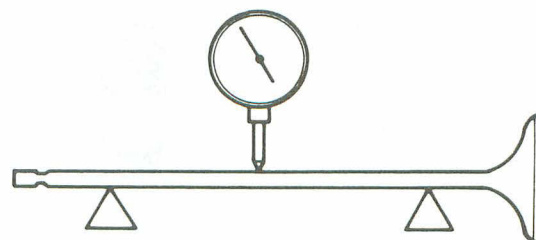

Item	Standard	Service Limit
Camshaft:		
Cam height		
Inlet	36.667 – 36.807 mm	36.57 mm
Exhaust	36.667 – 36.807 mm	36.57 mm
Camshaft bearing oil clearance	0.078 – 0.121 mm	0.21 mm
Camshaft journal diameter	24.900 – 24.922 mm	24.87 mm
Camshaft bearing inside diameter	25.000 – 25.021 mm	25.08 mm
Camshaft runout	not more than 0.02 mm TIR	0.1 mm TIR
Camshaft chain 20-link length	158.8 – 159.2 mm	161.5 mm
Rocker arm inside diameter	12.000 – 12.018 mm	12.05 mm
Rocker shaft diameter	11.976 – 11.994 mm	11.44 mm
Cylinder Compression:		
	(usable range)	
	860 – 1 320 kPa	
	(8.8 – 13.5 kg/cm ² , 125 – 192 psi) @370 r/min (rpm)	
Cylinder Block, Piston:		
Cylinder inside diameter	73.994 – 74.006 mm	74.11 mm
Piston diameter	73.935 – 73.950 mm	73.79 mm
Piston/cylinder clearance	0.044 – 0.071 mm	---
Oversize piston and rings	+0.5 mm	---
Piston ring/groove clearance		
Top	0.03 -- 0.07 mm	0.17 mm
Second	0.02 – 0.06 mm	0.16 mm
Piston ring groove width		
Top	0.82 – 0.84 mm	0.92 mm
Second	1.01 – 1.03 mm	1.12 mm
Oil	2.51 – 2.53 mm	2.6 mm
Piston ring thickness		
Top	0.77 – 0.79 mm	0.7 mm
Second	0.97 – 0.99 mm	0.9 mm
Piston ring end gap		
Top	0.2 – 0.35 mm	0.7 mm
Second	0.2 – 0.35 mm	0.7 mm
Oil	0.2 – 0.7 mm	1.0 mm

Cam Height Measurement

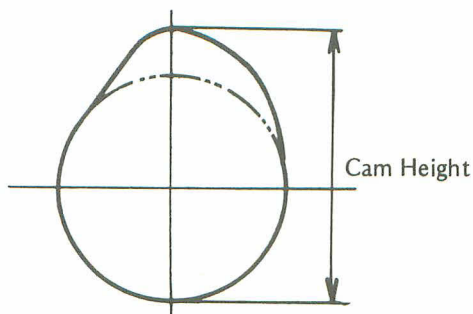

Camshaft Runout

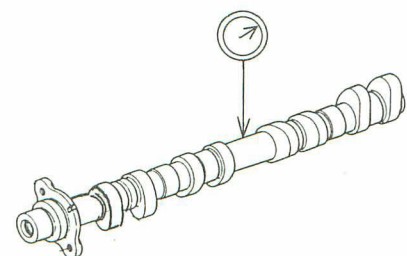

4-6 ENGINE TOP END

Special Tools

Piston Base: 57001-1263

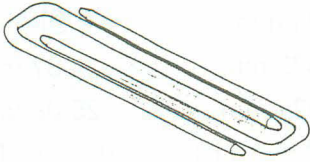

Compression Gauge: 57001-221
Adapter: 57001-1317

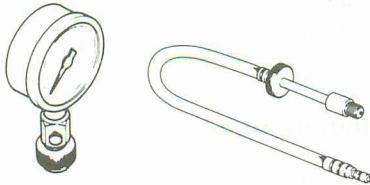

Valve Spring Compressor Assembly: 57001-241
Adapter: 57001-1202

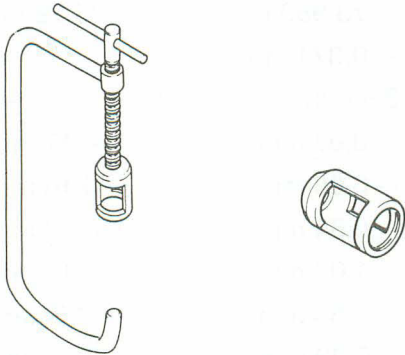

Piston Pin Puller Assembly: 57001-910

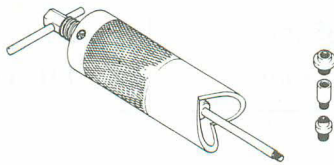

Piston Ring Compressor Assembly (4): 57001-1094

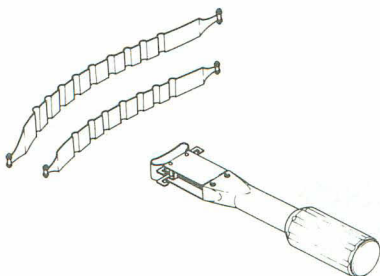

- Valve Seat Cutter 45° -φ32 : 57001-1115
- Valve Seat Cutter 45° -φ27.5: 57001-1114
- Valve Seat Cutter 32° -φ33: 57001-1199
- Valve Seat Cutter 32° -φ30: 57001-1120
- Valve Seat Cutter 60° -φ30: 57001-1123



Valve Guide Arbor: 57001-1203

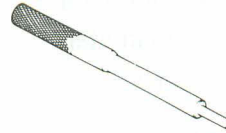

Valve Guide Reamer: 57001-1204



Valve Seat Cutter Holder: 57001-1208

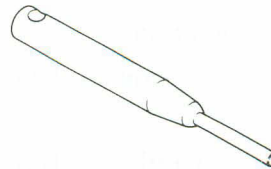

Bar: 57001-1128



.....
Clean Air System (US model)

Air Suction Valve Inspection

- Visually inspect the reeds for cracks, folds, warps, heat damage, or other damage.
- ★If there is any doubt as to the condition of the reed, replace the air suction valve as an assembly.

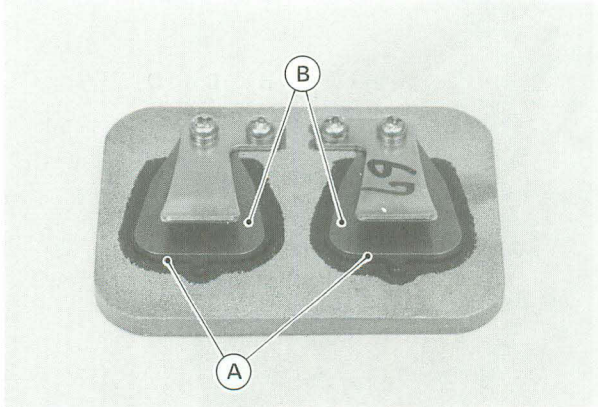

A. Valve Holder B. Reeds

- Check the reed contact areas of the valve holder for grooves, scratches, any signs of separation from the holder, or heat damage.
- ★If there is any doubt as to the condition of the reed contact areas, replace the air suction valve as an assembly.
- If any carbon or other foreign particles have accumulated between the reed and the reed contact area, wash the valve assembly with high flash-point solvent.

CAUTION

- Do not scrape off the deposits with a scraper as this could damage the rubber, requiring replacement of the suction valve assembly.

Vacuum Switch Valve Test

- Check the vacuum switch valve by blowing air into the air hose fitting.
- When the vacuum applied to the vacuum hose fitting of the valve is low, the vacuum switch valve is opened and air flows through the air hose fittings.
- When the vacuum rises gradually and reaches a certain level, the valve is closed and air does not flow.
- ★If the vacuum switch valve does not operate as described, replace the valve.

Vacuum Switch Valve Operation

1. During Cruising (open throttle)

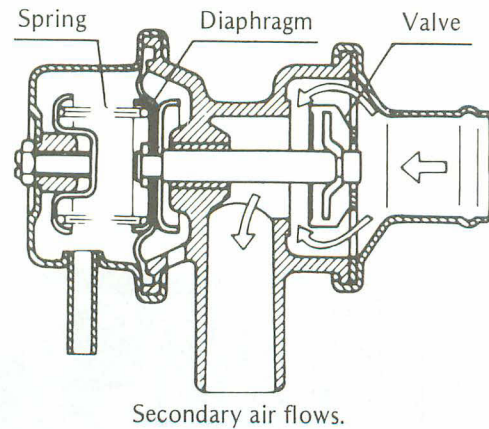

2. During Engine Braking

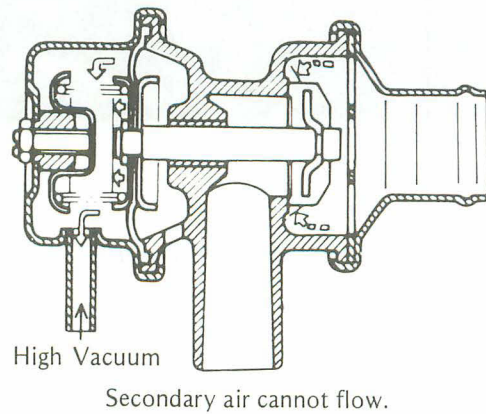

Vacuum Switch Valve Closing Pressure

Open → Close: 54 – 68 kPa (410 – 510 mmHg)

4-8 ENGINE TOP END

Cylinder Head Cover

Removal

- Remove the following.
 - Fairings
 - Fuel Tank
 - Spark Plug Caps
 - Carburetor
 - Baffle Plate

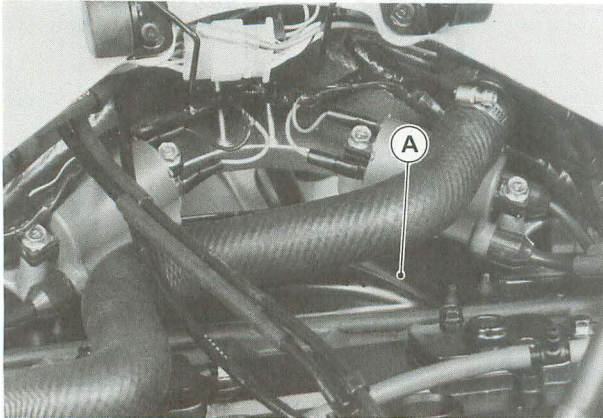

A. Baffle Plate

- Remove the cylinder head cover bolts and take off the cover.

Installation

- Installation is the reverse of removal. Note the following.
- Apply silicone sealant to the cylinder head as shown.

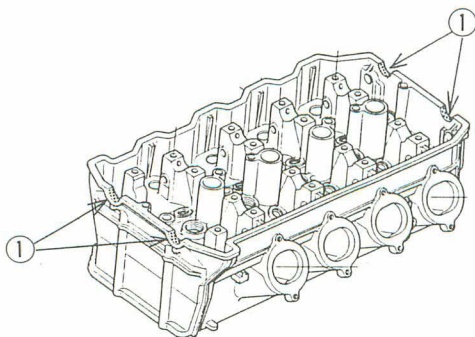

1. Silicone Sealant Applied Areas

- Tighten the cylinder head cover bolts to the specified torque (see Exploded View).

Camshaft Chain Tensioner

Removal

- Remove the tensioner cap bolt, copper washer and the spring.
- Remove the mounting bolts and take off the camshaft chain tensioner.

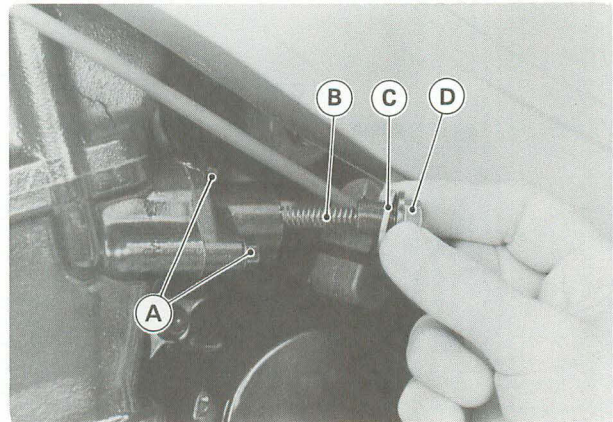

A. Mounting Bolts C. Copper Washer
B. Spring D. Cap Bolt

CAUTION

This is a non-return type cam chain tensioner. The push rod does not return to its original position once it moves out to take up cam chain slack. Observe all the rules listed below:

- When removing the tensioner, do not take out the mounting bolts only halfway. Retightening the mounting bolts from this position could damage the tensioner and the camshaft chain. Once the bolts are loosened, the tensioner must be removed and reset as described in "Chain Tensioner Installation."
- Do not turn over the crankshaft while the tensioner is removed. This could upset the cam chain timing, and damage the valves.

Installation

- Installation is the reverse of removal. Note the following.
- Release the stopper and push into the rod.

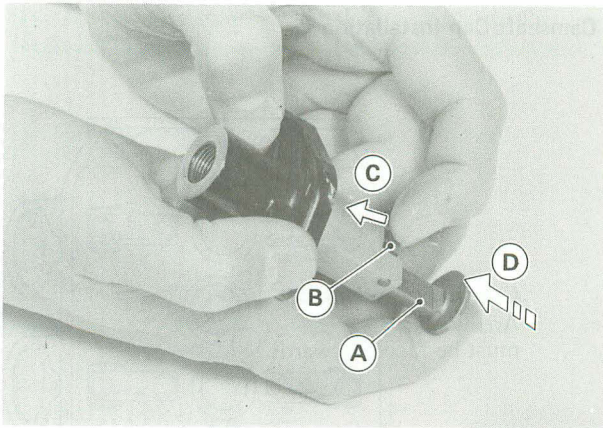

A. Push Rod C. Push
B. Stopper D. Push into the rod.

○Install the tensioner body with the arrow on it pointing upwards.

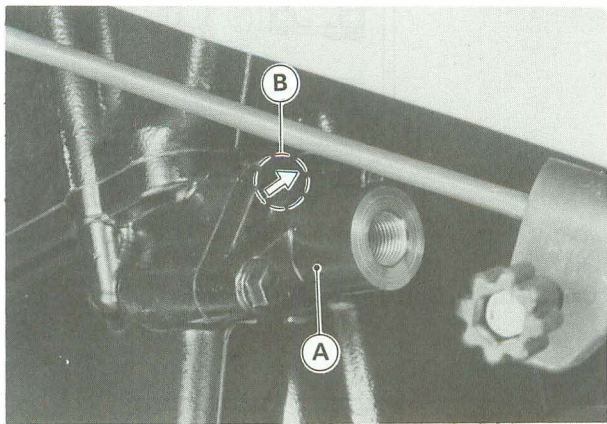

A. Tensioner Body B. Arrow Mark

●Tighten the tensioner mounting bolts and cap bolt to the specified torque (see Exploded View).

.....
Camshaft, Camshaft Chain, Rocker Shaft
.....

Camshaft, Rocker Shaft Removal

- Remove the following.
 - Cylinder Head Cover
 - Carburetors
 - Camshaft Chain Tensioner
- Drain the coolant about 500 mL, to remove the cooling hose.

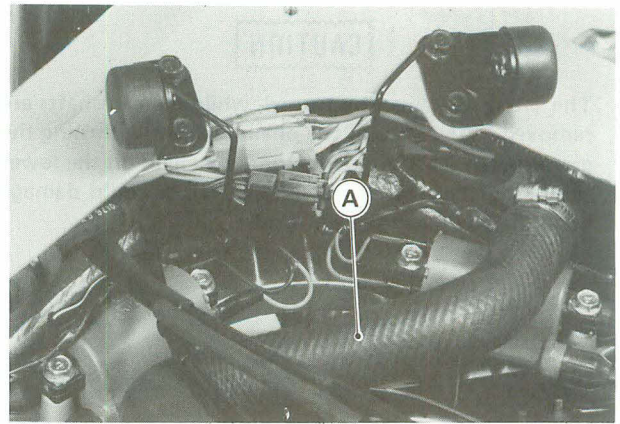

A. Cooling Hose

●Remove the camshaft caps, and take off the camshaft.

NOTE

○Remove the inlet rocker shaft, after removing the cylinder head.

●Remove the rocker shaft end bolt and spring.

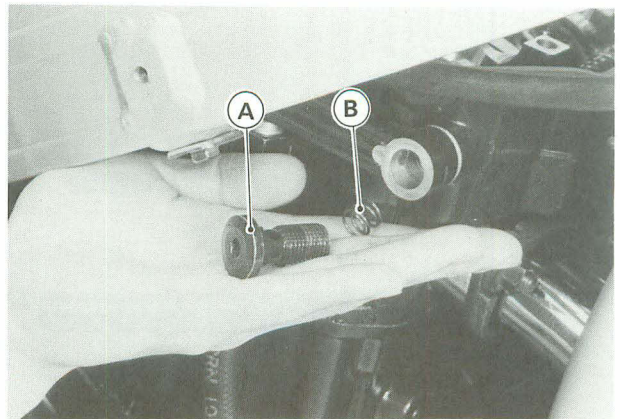

A. End Bolt B. Spring

●Using a suitable bolt (8 P 1.25 x more than 55 mm long), pull the rocker shaft out.

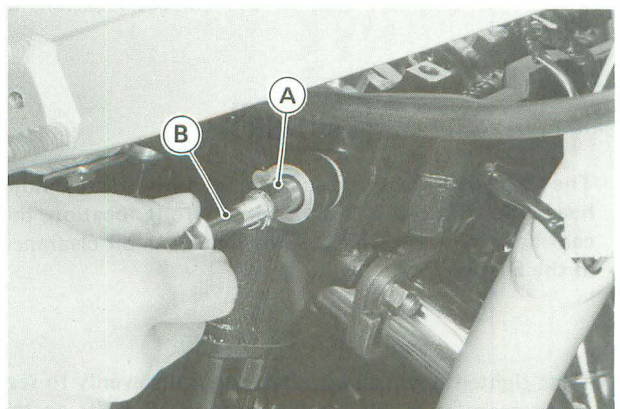

A. Rocker Shaft B. Bolt

4-10 ENGINE TOP END

CAUTION

○The crankshaft may be turned, while the camshafts are removed. Always pull the chain taut while turning the crankshaft. This avoids kinking the chain on the lower (crankshaft) sprocket. A kinked chain could damage both the chain and the sprocket.

Camshaft, Rocker Shaft Installation

- Installation is the reverse of removal. Note the following.
- Apply engine oil to all cam parts and journals.

NOTE

○The exhaust camshaft has an EX mark and the inlet camshaft has an IN mark. Be careful not to mix up these shafts.

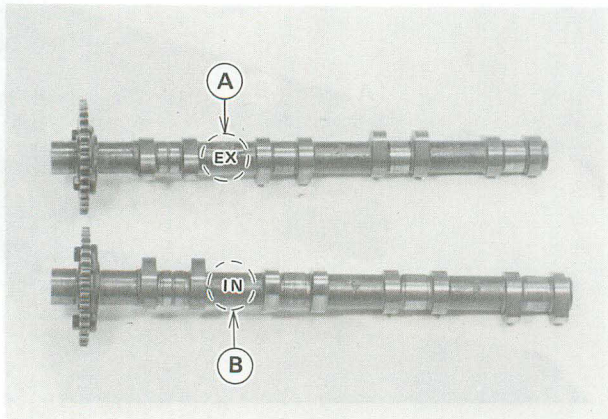

A. EX mark

B. IN mark

- Tighten the rocker shaft end bolts to the specified torque (see Exploded View).
- Install the camshaft caps in the correct locations as shown.

CAUTION

○The camshaft caps are machined with the cylinder head. So, if a cap is installed in a wrong location, the camshaft may seize because of improper oil clearance in the bearings.

○First tighten down all camshaft cap bolts evenly to seat the camshafts in place, then torque all bolts to the specified torque (see Exploded View).

Camshaft Cap Installation

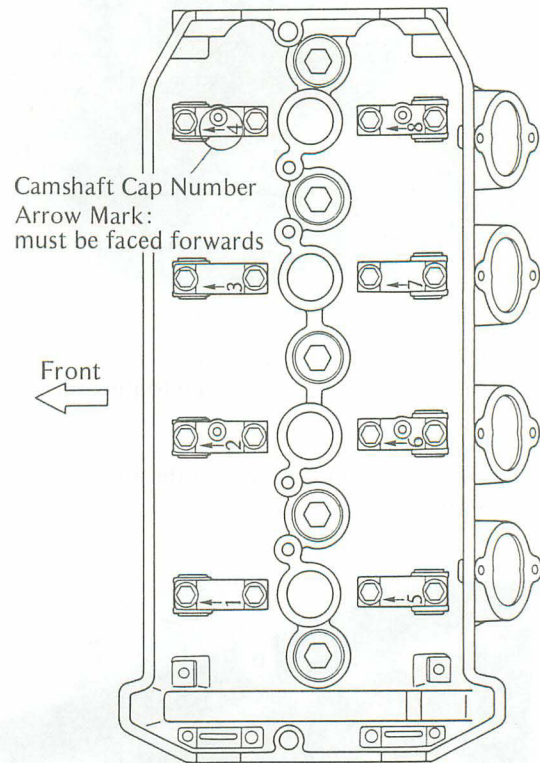

Camshaft Cap Bolt Tightening Sequence

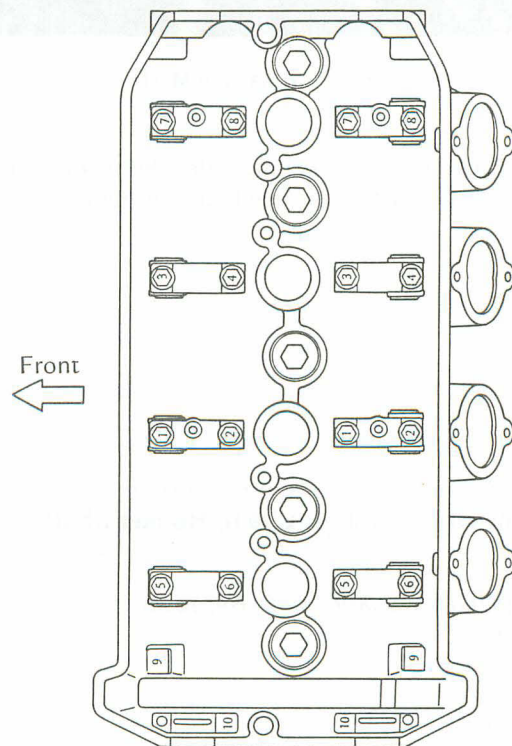

Chain Timing Procedure

- Position the crankshaft at TDC for the #1 and #4 pistons.

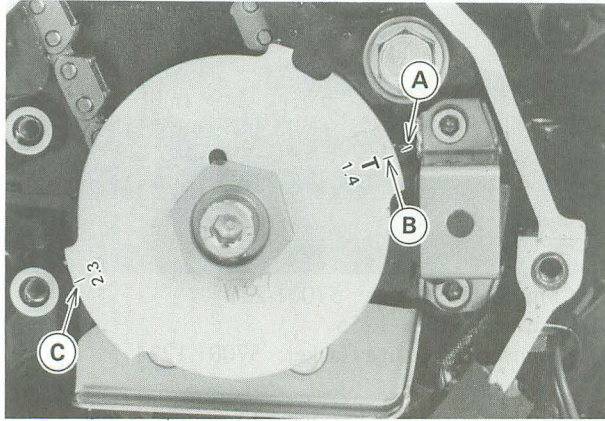

- A. Timing Mark
- B. TDC mark for #1 and #4 pistons
- C. TDC mark for #2 and #3 pistons

- Pull the tension side (exhaust side) of the chain taut to install the chain.
- The timing marks must be aligned with the cylinder head upper surface and positioned respectively as shown, after the camshaft chain slack is taken up by the tensioner.

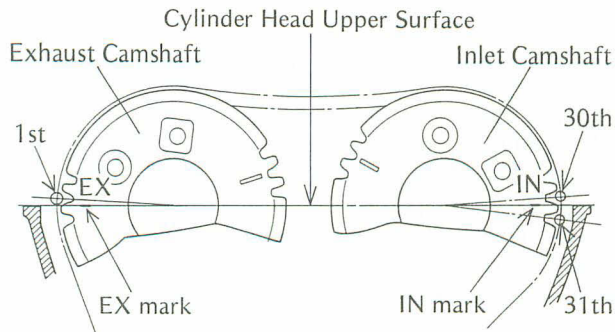

Camshaft and Sprocket Assembly

- Since the inlet and exhaust camshaft sprockets are the same, they have a set of bolt holes for the exhaust camshaft and another for the intake. Install the sprockets as shown.

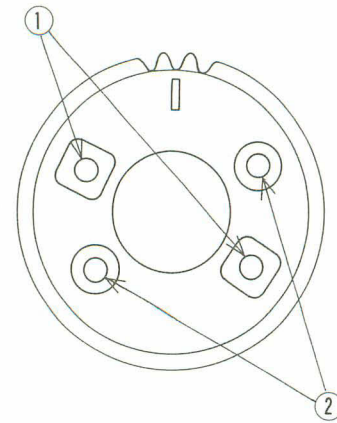

- 1. Bolt Holes for the Inlet Camshaft
- 2. Bolt Holes for the Exhaust Camshaft

- Install the sprockets so that the marked side faces outwards.
- Apply a locking agent to the camshaft sprocket bolts and tighten them to the specification (see Exploded View).
- If a new camshaft is to be used, apply a thin coat of a molybdenum disulfide grease to the cam surfaces.

Camshaft, Camshaft Cap Wear

- Measure each clearance between the camshaft and the camshaft cap using plastigage (press gauge).

NOTE

- Tighten the camshaft cap bolts to the specified torque (see Exploded View).

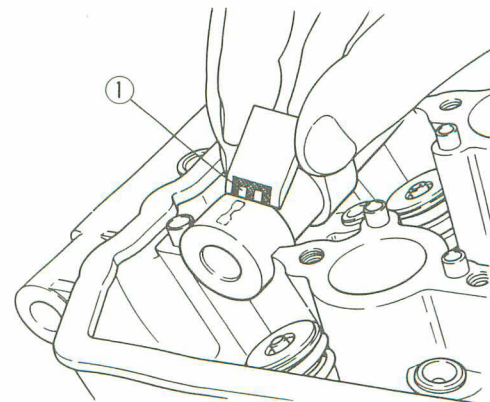

- 1. Plastigage Width

4-12 ENGINE TOP END

NOTE

○Do not turn the camshaft when the plastigage is between the journal and camshaft cap.

★If any clearance exceeds the service limit, replace the camshaft with a new one and measure the clearance again.

★If the clearance still remains out of the limit, replace the cylinder head unit.

Camshaft Bearing Oil Clearance

Standard: 0.078 – 0.121 mm
Service Limit: 0.21 mm

Camshaft Chain Wear

●Hold the chain taut with a force of about 5 kg in some manner, and measure a 20-link length. Since the chain may wear unevenly, take measurements at several places.

★If any measurement exceeds the service limit, replace the chain.

Camshaft Chain 20-link Length

Standard: 158.8 – 159.2 mm
Service Limit: 161.5 mm

Chain Length Measurement

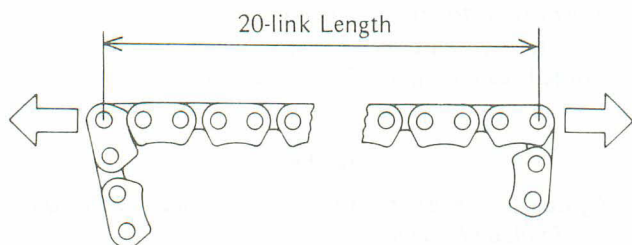

Cylinder Head

Cylinder Compression Measurement

- Perform the following.
- Warm up the engine thoroughly and then remove the spark plugs.
- Attach the compression gauge, adapter and gasket (special tools) firmly into the spark plug hole.

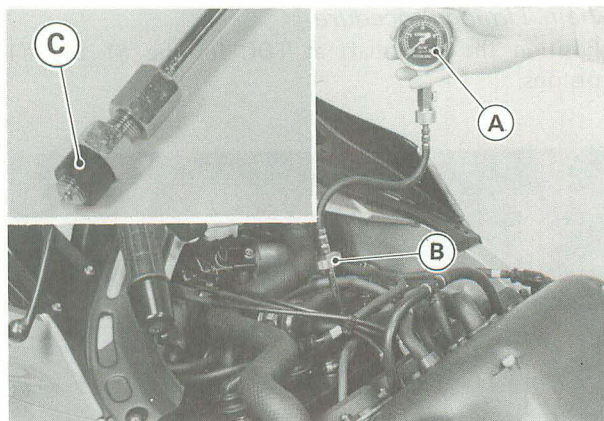

A. Compression Gauge: 57001-221
B. Adapter: 57001-1255
C. Compression Gauge Gasket: 57001-1224

- Hold the throttle wide open and crank the engine with the starter.
- When the gauge stops rising, stop cranking and read the gauge.

Cylinder Compression

Usable Range: 860 – 1 320 kPa @370 r/min (rpm)
(8.8 – 13.5 kg/cm², 125 – 192 psi)

NOTE

○Use the battery which is fully charged.

★If cylinder compression is higher than the specified range, check the following.

○Carbon build-up on the cylinder head combustion chamber

○Carbon build-up on the piston head

★If cylinder compression is lower than the specified range, check the following.

○Valve not seating properly

○Piston/cylinder clearance excessive

○Gas leakage around the cylinder head gasket

○Valve clearance too small

Removal

●Remove the following.

- Fairing
- Coolant (Drain)
- Fuel Tank
- Radiator
- Mufflers
- Oil Hose (Cylinder head right side)
- Carburetors
- Cylinder Head Cover
- Camshaft Chain Tensioner
- Camshafts

NOTE

○Remove the cylinder head bolt (6 mm) and the cylinder bolts first, then remove the cylinder head bolts. This prevents excessive stress on the small bolts.

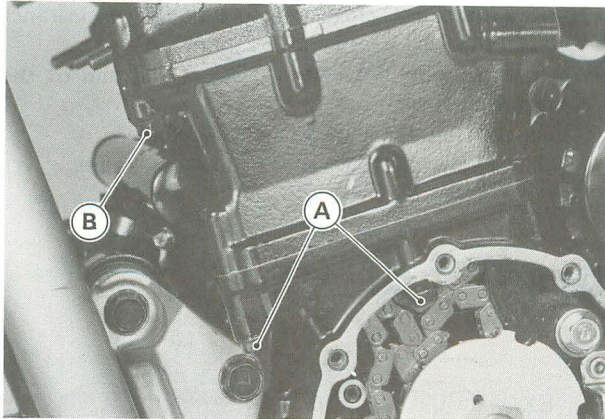

A. Cylinder Bolts B. Cylinder Head Bolt (6 mm)

●Remove the cylinder head bolts and take off the cylinder head.

Installation

- Installation is the reverse of removal. Note the following.
- Install the left most camshaft cap on the cylinder head.
- Install the two camshaft cap bolts through the leftmost camshaft cap and cylinder head.
- Install the cylinder head on the cylinder.

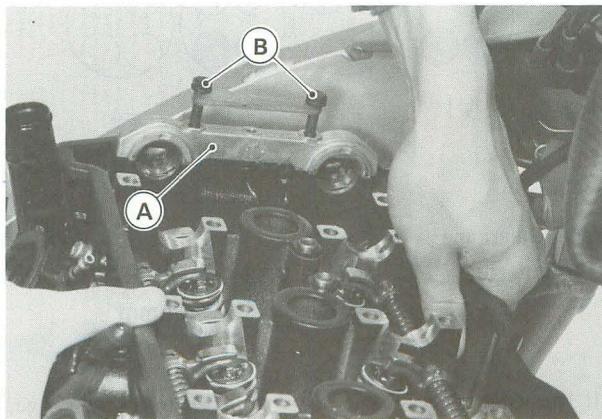

A. Leftmost camshaft cap B. Bolts

NOTE

○The bolts can not be put into the leftmost camshaft cap after the cylinder head has been installed due to insufficient clearance between the camshaft cap bolts and the frame.

NOTE

○The camshaft caps are machined with the cylinder head so if a new cylinder head is installed, use the caps that are supplied with the new head.

●Apply engine oil to the both sides of the cylinder head bolt washers.

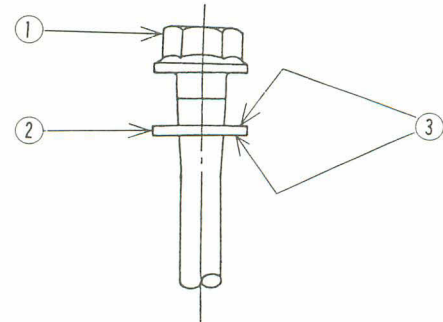

1. Cylinder Head Bolt
2. Washer
3. Apply engine oil.

Location of Cylinder Head Bolts

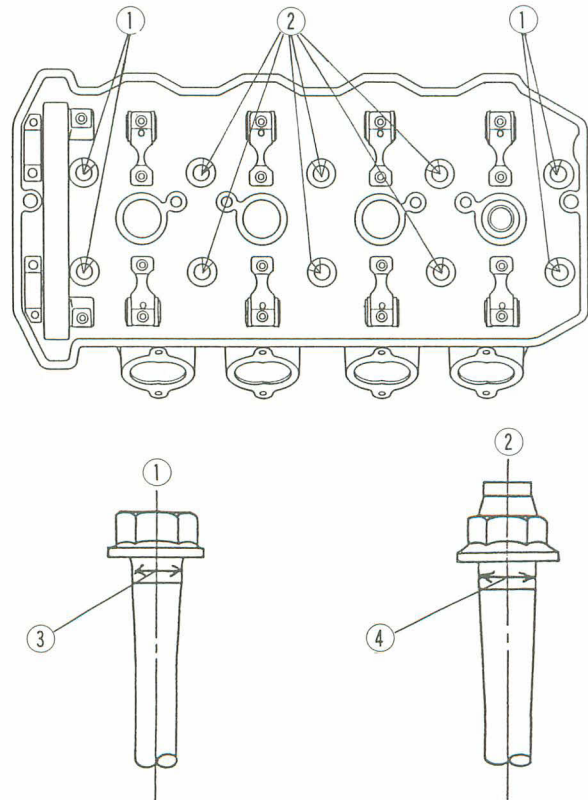

1. 10 mm Dia. Bolt
2. 11 mm Dia. Bolt
3. 10 mm
4. 11 mm

4-14 ENGINE TOP END

- Torque the cylinder head bolts following the tightening sequence.
- Tighten them first to 20 N-m (2.0 kg-m, 14.5 ft-lb), and then tighten them to the specified torque (see Exploded View).

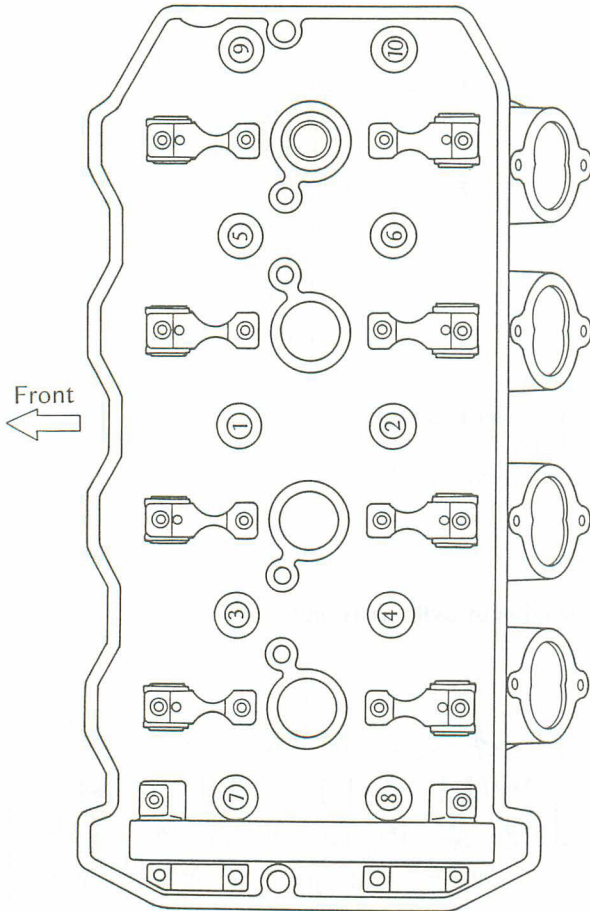

- Tighten the cylinder bolts and cylinder head bolt (6 mm) to the specified torque (see Exploded View).

Valves

Valve Clearance Adjustment

NOTE

- Valve clearance must be checked and adjusted when the engine is cold (at room temperature).

Fairing
Coolant (Drain)
Fuel Tank
Cooling Hose
Baffle Plate
Pickup Coil Cover
Cylinder Head Cover

- Using a thickness gauge, measure the valve clearance between the rocker arm and the shim.
- When positioning #4 piston TDC at the end of the compression stroke:
inlet valve clearance of #2 and #4 cylinders
exhaust valve clearance of #3 and #4 cylinders

Measuring Valves

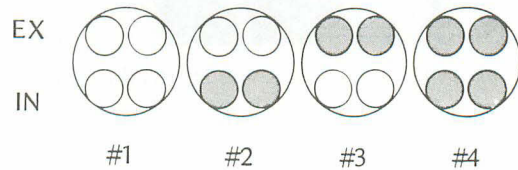

- When positioning #1 piston TDC at the end of the compression stroke:
inlet valve clearance of #1 and #3 cylinders
exhaust valve clearance of #1 and #2 cylinders

Measuring Valves

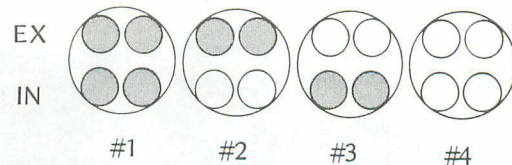

Valve Clearance

Standard:	IN. 0.13 – 0.19 mm
	EX. 0.18 – 0.24 mm

- ★ If the valve clearance is not within the specified range, adjust the valve clearance.
- Adjust the valve clearance, as follows.

NOTE

- To select a new shim which brings valve clearance within the specification period. Refer to the Valve Clearance Adjustment charts.

Inlet Valve Clearance Adjustment Chart

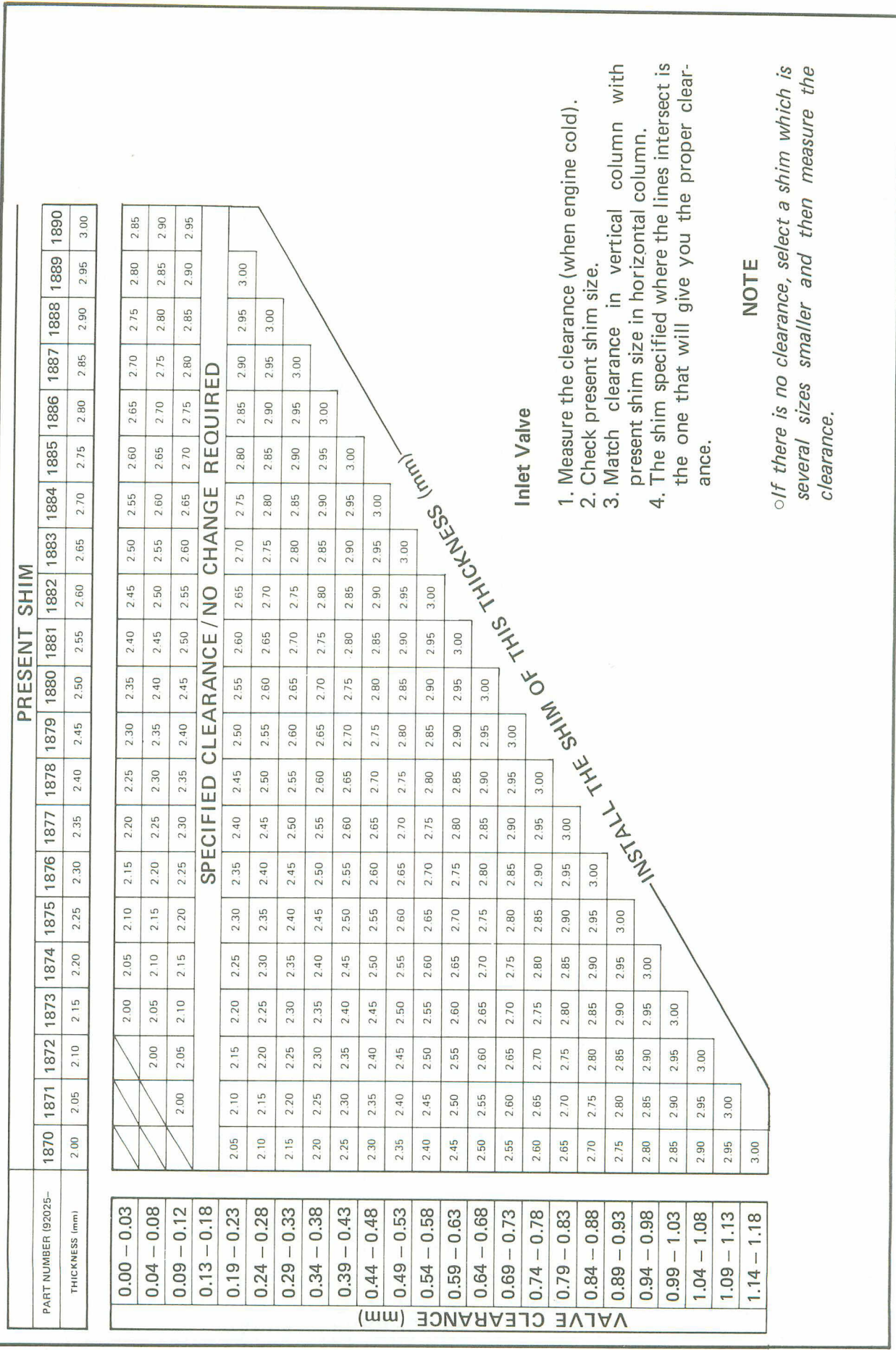

Exhaust Valve Clearance Adjustment Chart

PART NUMBER (92025- THICKNESS (mm))	PRESENT SHIM																					
	1870	1871	1872	1873	1874	1875	1876	1877	1878	1879	1880	1881	1882	1883	1884	1885	1886	1887	1888	1889	1890	
0.00 - 0.03					2.00	2.05	2.10	2.15	2.20	2.25	2.30	2.35	2.40	2.45	2.50	2.55	2.60	2.65	2.70	2.75	2.80	2.85
0.04 - 0.08				2.00	2.05	2.10	2.15	2.20	2.25	2.30	2.35	2.40	2.45	2.50	2.55	2.60	2.65	2.70	2.75	2.80	2.85	2.90
0.09 - 0.13		2.00	2.05	2.10	2.15	2.20	2.25	2.30	2.35	2.40	2.45	2.50	2.55	2.60	2.65	2.70	2.75	2.80	2.85	2.90	2.95	3.00
0.14 - 0.17	2.00	2.05	2.10	2.15	2.20	2.25	2.30	2.35	2.40	2.45	2.50	2.55	2.60	2.65	2.70	2.75	2.80	2.85	2.90	2.95	3.00	
0.18 - 0.23																						
0.24 - 0.28																						
0.29 - 0.33																						
0.34 - 0.38																						
0.39 - 0.43																						
0.44 - 0.48																						
0.49 - 0.53																						
0.54 - 0.58																						
0.59 - 0.63																						
0.64 - 0.68																						
0.69 - 0.73																						
0.74 - 0.78																						
0.79 - 0.83																						
0.84 - 0.88																						
0.89 - 0.93																						
0.94 - 0.98																						
0.99 - 1.03																						
1.04 - 1.08																						
1.09 - 1.13																						
1.14 - 1.18																						
1.19 - 1.23																						

VALVE CLEARANCE (mm)

Exhaust Valve

INSTALL THE SHIM OF THIS THICKNESS (mm)

SPECIFIED CLEARANCE / NO CHANGE REQUIRED

1. Measure the clearance (when engine cold).
2. Check present shim size.
3. Match clearance in vertical column with present shim size in horizontal column.
4. The shim specified where the lines intersect is the one that will give you the proper clearance.

NOTE

If there is no clearance, select a shim which is several sizes smaller and then measure the clearance.

○Slide the rocker arm sideways and change the shim.

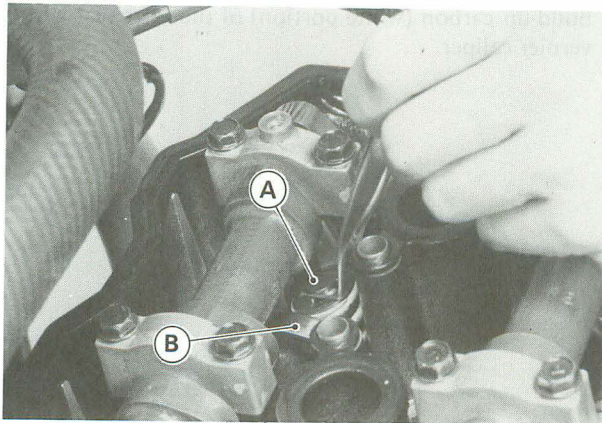

A. Shim B. Rocker Arm

○Remeasure the valve clearance that was adjusted. Re-adjust if necessary.

CAUTION

- Do not put shim stock under the shim. This may cause the shim to pop out at high rpm, causing extensive engine damage.
- Do not grind the shim. This may cause it to fracture, causing extensive engine damage.

Valve Removal

- Using the valve spring compressor assembly (special tool), remove the valve.

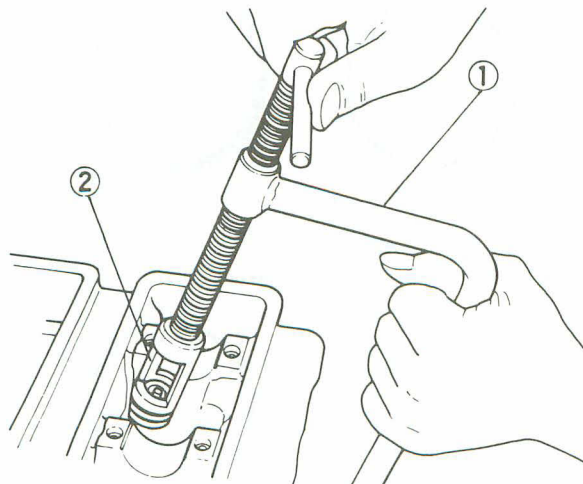

1. Valve Spring Compressor Assembly: 57001-241
2. Adapter: 57001-1202

Valve Installation

- Apply a thin coat of molybdenum disulfide grease to the valve stem before valve installation.
- Install the springs so that the closed coil end faces downwards.

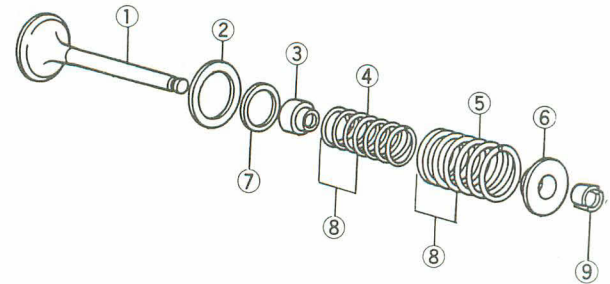

1. Valve Stem 6. Retainer
2. Spring Seats 7. Spring Seat
3. Oil Seal 8. Closed Coil End
4. Inner Spring 9. Split Keepers
5. Outer Spring

Valve Guide Removal

- Using the valve guide arbor (special tool), tap out the valve guide.

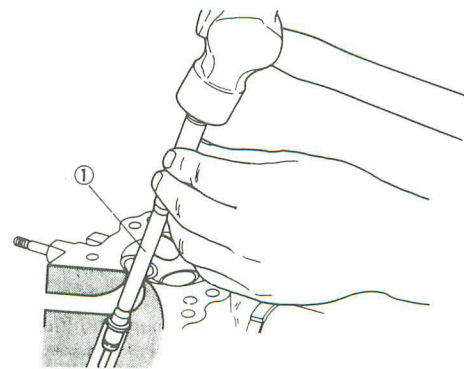

1. Valve Guide Arbor: 57001-1203

NOTE

○Heat the area around the valve guide to 120 – 150°C (248 – 302°F).

4-18 ENGINE TOP END

Valve Guide Installation

- Using the valve guide arbor (special tool), drive the valve guide until its flange touches to the cylinder head.

NOTE

- Heat the area around the valve guide hole to 120 – 150°C (248 – 302°F).
- Apply oil to the valve guide outer surface before valve guide installation.
- Using the valve guide reamer (special tool), ream the valve guide.

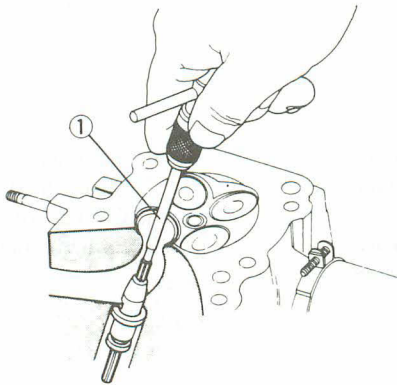

1. Valve Guide Reamer: 57001-1204

Valve Face Contact Inspection

- Check the valve face seating surface width.
- Measure the seat width of the portion where there is no build-up carbon (white portion) of the valve face with a vernier caliper.
- ★ If the valve face seating surface width is not within the specified range, replace the valve with a new one.

Valve Seat Outside Diameter

- If the outside diameter of the seating pattern on the valve seat is too large or too small, repair the valve seat.

Valve Seating Surface Outside Diameter

- Standard: Inlet: 29.3 – 29.5 mm
 Exhaust: 25.3 – 25.5 mm

Valve Seat Width Inspection

- Check the valve seating surface width.
- Measure the seat width of the portion where there is no build-up carbon (white portion) of the valve seat with a vernier caliper.

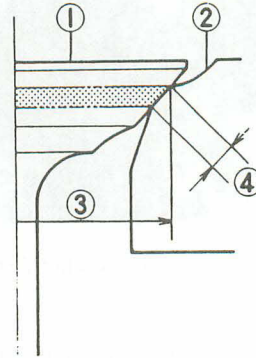

1. Valve
2. Valve Seat
3. Seating Surface Outside Diameter
4. Seating Surface Width

Valve Seating Surface Width (IN and EX)

Standard: 0.5 – 1.0 mm

- ★ If the valve seating surface width is not within the specified range, repair the valve seat.

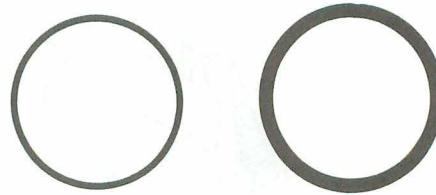

1. Good
2. Too wide



3. Too narrow
4. Uneven

Valve Seat Repair (Valve Lapping)

●Using the valve seat cutters (special tools), repair the valve seat.

Valve Seat Cutters

Inlet Valves:	45° – ϕ 32	57001-1115
	32° – ϕ 33	57001-1199
	60° – ϕ 30	57001-1123
Exhaust Valves:	45° – ϕ 27.5	57001-1114
	32° – ϕ 30	57001-1120
	60° – ϕ 30	57001-1123

Holder and Bar

Holder:	57001-1208
Bar:	57001-1128

★If the manufacturer's instructions are not available, use the following procedure.

Seat Cutter Operating Care:

1. This valve seat cutter is developed to grind the valve for repair. Therefore the cutter must not be used for other purposes than seat repair.
2. Do not drop or shock the valve seat cutter, or the diamond particles may fall off.
3. Do not fail to apply engine oil to the valve seat cutter before grinding the seat surface. Also wash off ground particles sticking to the cutter with washing oil.

NOTE

○Do not use a wire brush to remove the metal particles from the cutter. It will take off the diamond particles.

4. Setting the valve seat cutter holder in position, operate the cutter in one hand. Do not apply too much force to the diamond portion.

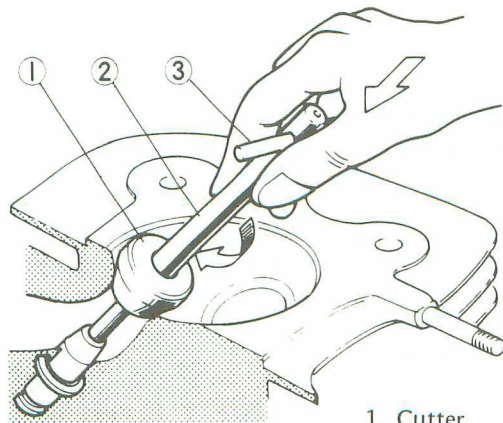

1. Cutter
2. Cutter Holder
3. Bar

NOTE

○Prior to grinding, apply engine oil to the cutter and during the operation, wash off any ground particles sticking to the cutter with washing oil.

5. After use, wash it with washing oil and apply thin layer of engine oil before storing.

Marks Stamped on the Cutter:

The marks stamped on the back of the cutter represent the following.

- 45°Cutter angle
24.5 ϕ Outer diameter of cutter

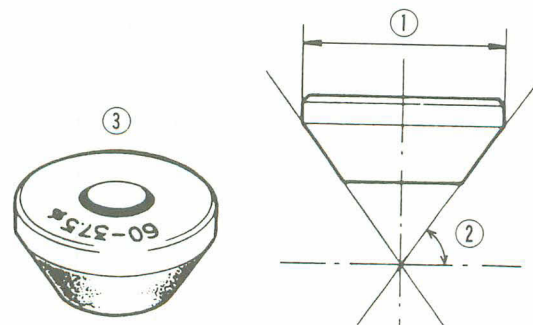

1. Outer Diameter of Cutter
2. Angle of Cutter
3. Cutter

Operating Procedures:

- Clean the seat area carefully.
- Coat the seat with machinist's dye.
- Fit a 45° cutter to the holder and slide it into the valve guide.
- Press down lightly on the handle and turn it right or left. Grind the seating surface only until it is smooth.

CAUTION

○Do not grind the seat too much. Overgrinding will reduce valve clearance by sinking the valve into the head. If the valve sinks too far into the head, it will be impossible to adjust the clearance, and the cylinder head must be replaced.

- Measure the outside diameter of the seating surface with a vernier caliper.
- ★If the outside diameter of the seating surface is too small, repeat the 45° grind until the diameter is within the specified range.

4-20 ENGINE TOP END

- ★If the outside diameter of the seating surface is too large, make the 32° grind described below.
- ★If the outside diameter of the seating surface is within the specified range, measure the seat width as described below.
- Grind the seat at a 32° angle until the seat O.D. is within the specified range.
- To make the 32° grind, fit a 32° cutter to the holder, and slide it into the valve guide.
- Turn the holder one turn at a time while pressing down very lightly. Check the seat after each turn.

CAUTION

- The 32° cutter removes material very quickly. Check the seat outside diameter frequently to prevent over-grinding.

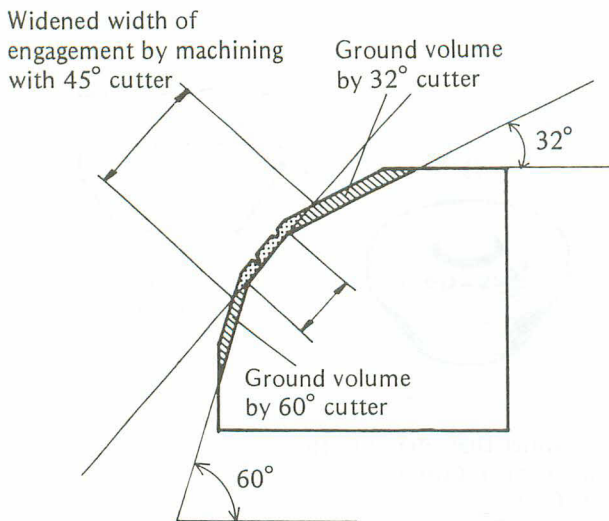

- After making the 32° grind, return to the seat O.D. measurement step above.
- To measure the seat width, use a vernier caliper to measure the width of the 45° angle portion of the seat at several places around the seat.
- ★If the seat width is too narrow, repeat the 45° grind until the seat is slightly too wide, and then return to the seat O.D. measurement step above.
- ★If the seat width is too wide, make the 60° grind described below.
- Grind the seat at a 60° angle until the seat width is within the specified range.
- To make the 60° grind, fit 60° cutter to the holder, and slide it into the valve guide.
- Turn the holder, while pressing down lightly.
- After marking the 60° grind, return to the seat width measurement step above.

- Lap the valve to the seat, once the seat width and O.D. are within the ranges specified above.
- Put a little coarse grinding compound on the face of the valve in a number of places around the valve head.
- Spin the valve against the seat until the grinding compound produces a smooth, matched surface on both the seat and the valve.
- Repeat the process with a fine grinding compound.
- The seating area should be marked about in the middle of the valve face.
- ★If the seat area is not in the right place on the valve, check to be sure the valve is the correct part. If it is, it may have been refaced too much; replace it.
- Be sure to remove all grinding compound before assembly.
- When the engine is assembled, be sure to adjust the valve clearance (see Valve Clearance Adjustment).

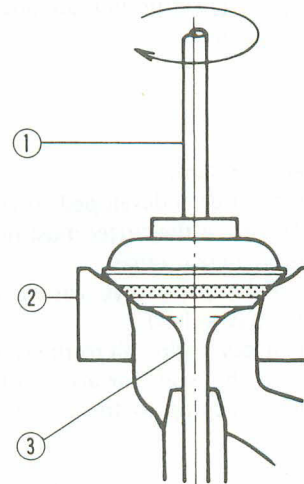

1. Lapper 3. Valve
2. Valve Seat

Measuring Valve-to-Guide Clearance (Wobble Method)

- If a small bore gauge is not available, inspect the valve guide wear by measuring the valve to valve guide clearance with the wobble method, as indicated below.
- Insert a new valve into the guide and set a dial gauge against the stem perpendicular to it as close as possible to the cylinder head mating surface.
 - Move the stem back and forth to measure valve/valve guide clearance.
 - Repeat the measurement in a direction at a right angle to the first.
 - ★If the reading exceeds the service limit, replace the guide.

NOTE

○The reading is not actual valve/valve guide clearance because the measuring point is above the guide.

**Valve/Valve Guide Clearance
(Wobble Method)**

	Standard	Service Limit
Inlet	0.02 – 0.07 mm	0.18 mm
Exhaust	0.06 – 0.11 mm	0.21 mm

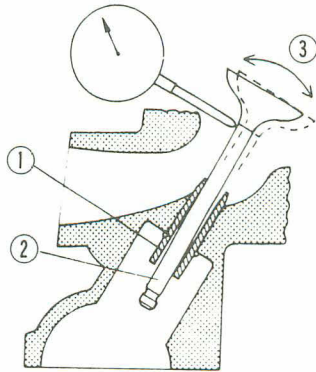

- 1. Valve Guide
- 2. New Valve
- 3. Move the Valve.

Cylinder, Piston

Cylinder Removal

- Remove the cylinder head.
- Remove the cylinder bolts.

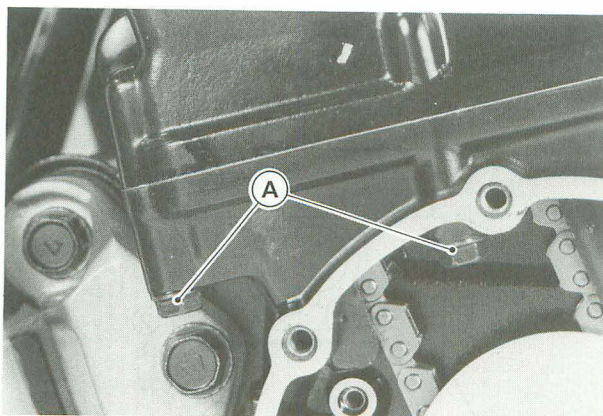

A. Cylinder Bolts

- Remove the cylinder.

Cylinder Installation

- Apply engine oil to the cylinder bore.
- Using the piston base and piston ring compressor assemblies (special tools), install the cylinder block.

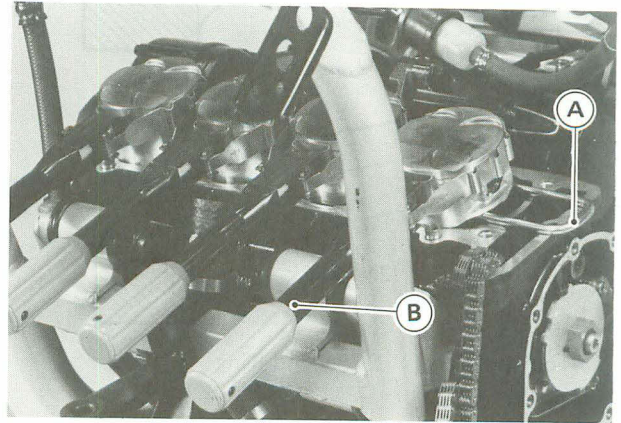

- A. Piston Base: 57001-1263
- B. Piston Ring Compressor Assembly: 57001-1094

Piston Removal

- Remove the cylinder.
- Place a clean cloth under the pistons and remove the piston pin snap rings from the outside of each piston.
- Using the piston pin puller assembly (special tool), remove the piston pins.

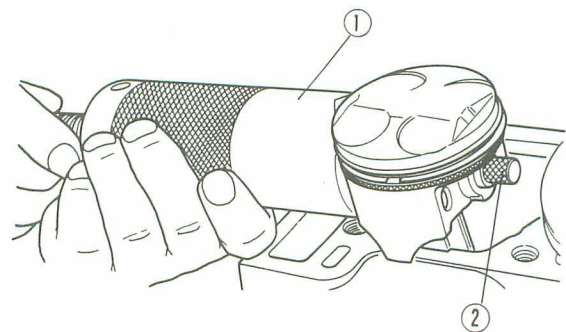

- 1. Piston Pin Puller Assembly: 57001-910
- 2. Adapter

Piston Installation

- The top and second rings must be installed with the N or 2N marks on the rings facing up.

4-22 ENGINE TOP END

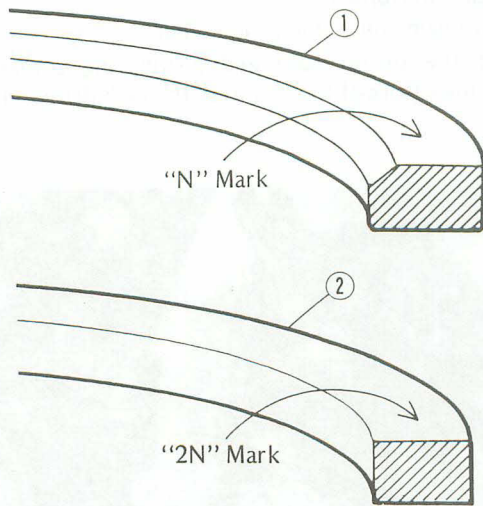

1. Top Ring 2. Second Ring

●The piston ring openings must be positioned as shown below. The openings of the oil ring steel rails must be about 30 – 40° of angle from the opening of the top ring.

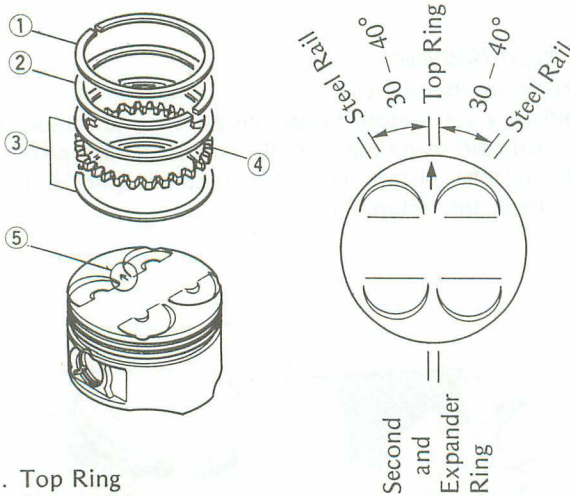

1. Top Ring
2. Second Ring
3. Oil Ring Steel Rails
4. Oil Ring Expander
5. Arrow

●The arrow on the piston head must point toward the front of the engine.

CAUTION

○Do not reuse snap rings, as removal weakens and deforms them. They could fall out and score the cylinder wall.

Cylinder Wear

●Measure the cylinder inside diameter taking a side-to-side and a front-to-back measurement at each of the 3 positions (total of 6 measurements) shown below.

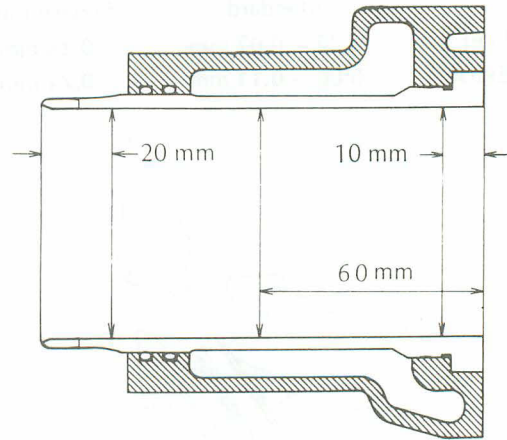

Cylinder Inside Diameter:

Standard: 73.994 – 74.006 mm
Service Limit: 74.11 mm

Piston Wear

●Measure the piston outside diameter 5 mm up from the bottom of the piston at a right angle to the direction of the piston pin.

Piston Outside Diameter

Standard: 73.935 – 73.950 mm
Service Limit: 73.79 mm

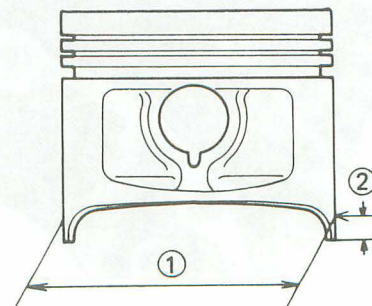

1. Piston Outside Diameter
2. 5 mm up from bottom

Piston Ring, Piston Ring Groove Wear

- Check for uneven groove wear by inspecting the ring seats.
- ★The rings should fit perfectly parallel to the groove surfaces. If not, the piston must be replaced.
- With the piston rings in their grooves, make several measurements with a thickness gauge to determine piston ring/groove clearance.

Piston Ring/Groove Clearance

	Standard	Service Limit
Top	0.03 ~ 0.07 mm	0.17 mm
Second	0.02 ~ 0.06 mm	0.16 mm

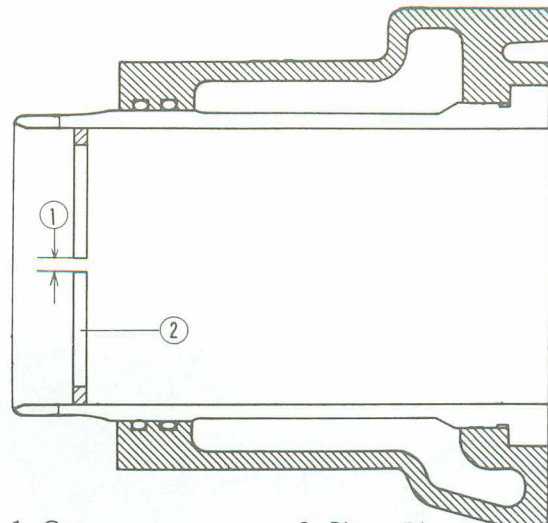

1. Gap

2. Piston Ring

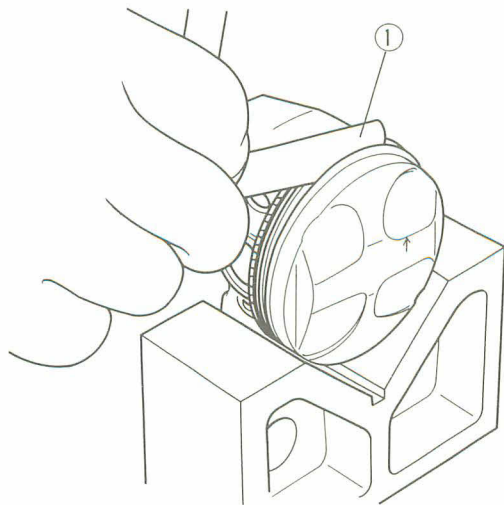

1. Thickness Gauge

Piston Ring End Gap

- Place the piston ring inside the cylinder, using the piston to locate the ring squarely in place. Set it close to the bottom of the cylinder, where cylinder wear is low.
- Measure the gap between the ends of the ring with a thickness gauge.

Piston Ring End Gap

	Standard	Service Limit
Top	0.20 ~ 0.35 mm	0.7 mm
Second	0.20 ~ 0.35 mm	0.7 mm

Carburetor Holder

Carburetor Holder Installation

- Install the carburetor holder so that the pipe is upward. Be careful of the clamp screw position.

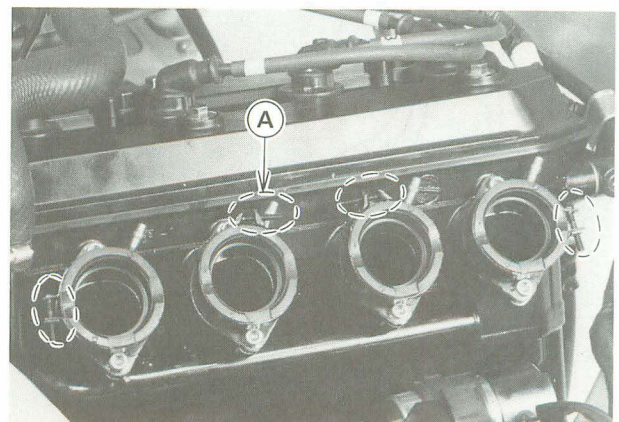

A. Clamp Screws

WARNING

- Operation with an improperly installed carburetor holder clamps could result in an unsafe riding condition.

4-24 ENGINE TOP END

Muffler

Removal

- Remove the following.
 - Coolant (draining)
 - Radiator
 - Horns (both left and right)
- Remove the nuts and take off the exhaust pipe holders.

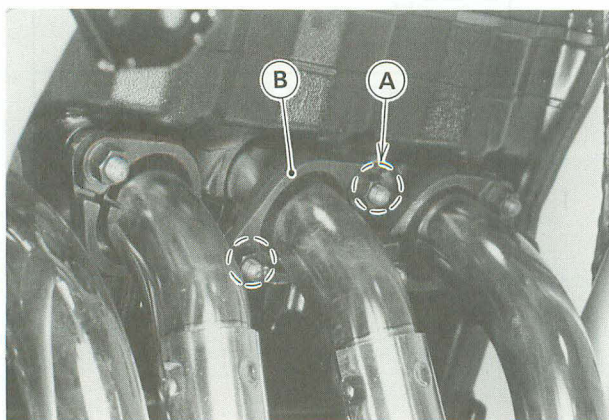

A. Nuts

B. Holders

- Loosen the muffler clamp bolt.
- Remove the muffler mounting bolts.

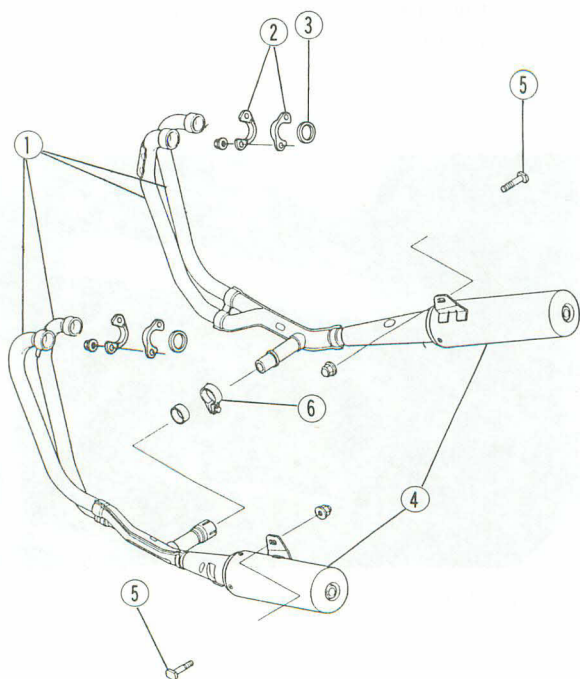

- | | |
|-------------------|------------------|
| 1. Exhaust Pipes | 4. Muffler |
| 2. Holders | 5. Mounting Bolt |
| 3. Exhaust Gasket | 6. Clamp |

Clutch

Table of Contents

5

Exploded View	5-2
Specifications	5-4
Special Tool	5-4
Clutch Fluid	5-5
Fluid Level Inspection.	5-5
Clutch Fluid Changing.	5-5
Bleeding the Clutch Line.	5-6
Master Cylinder.	5-6
Installation	5-6
Disassembly.	5-6
Assembly.	5-7
Inspection	5-7
Clutch Slave Cylinder	5-7
Removal	5-7
Installation	5-7
Disassembly.	5-8
Assembly.	5-8
Clutch	5-8
Removal	5-8
Installation	5-9
Friction Plate Wear	5-10
Friction and Steel Plate Warp	5-10
Clutch Spring Free Length Measurement.	5-11

5-2 CLUTCH

Exploded View

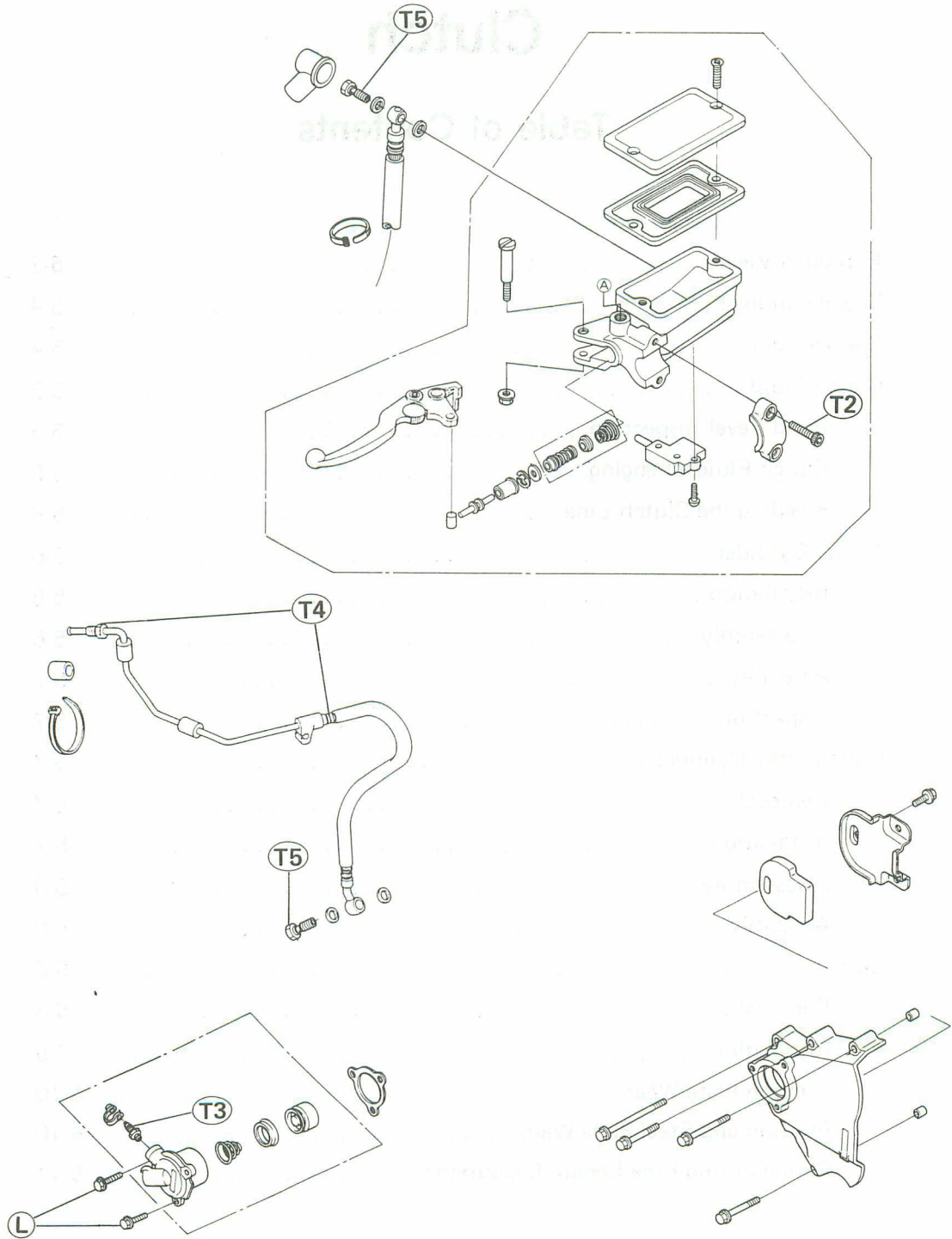

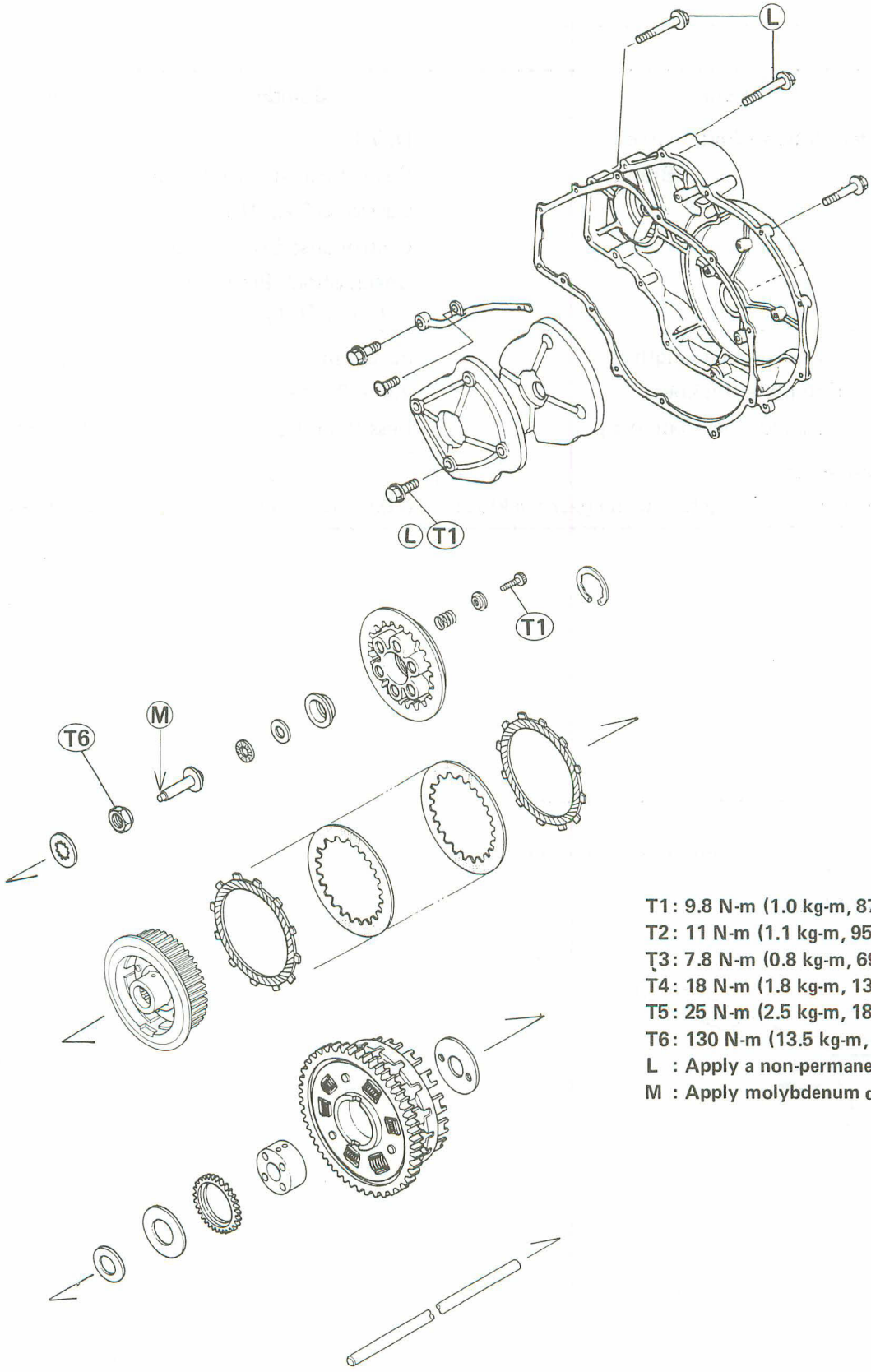

- T1: 9.8 N-m (1.0 kg-m, 87 in-lb)
- T2: 11 N-m (1.1 kg-m, 95 in-lb)
- T3: 7.8 N-m (0.8 kg-m, 69 in-lb)
- T4: 18 N-m (1.8 kg-m, 13.0 ft-lb)
- T5: 25 N-m (2.5 kg-m, 18.0 ft-lb)
- T6: 130 N-m (13.5 kg-m, 98 ft-lb)
- L : Apply a non-permanent locking agent.
- M : Apply molybdenum disulfide grease.

5-4 CLUTCH

.....
Specifications
.....

Item	Standard	Service Limit
Recommended Clutch Fluid: Grade Brand	D.O.T.4 Castrol Girling–Universal Castrol GT (LMA) Castrol Disc Brake Fluid Check Shock Premium Heavy Duty	
Clutch: Clutch spring free length Friction plate thickness Friction and steel plate warp	33.2 mm 2.9 – 3.1 mm Less than 0.2 mm	32.1 mm 2.75 mm 0.3 mm
Primary Reduction: Primary gear/clutch housing gear backlash	0.03 – 0.10 mm	0.14 mm

.....
Special Tool
.....

Clutch Holder: 57001-1243

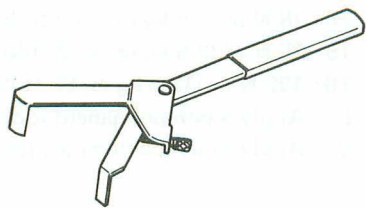

Clutch Fluid

Fluid Level Inspection

- Check the clutch fluid level in the reservoir.

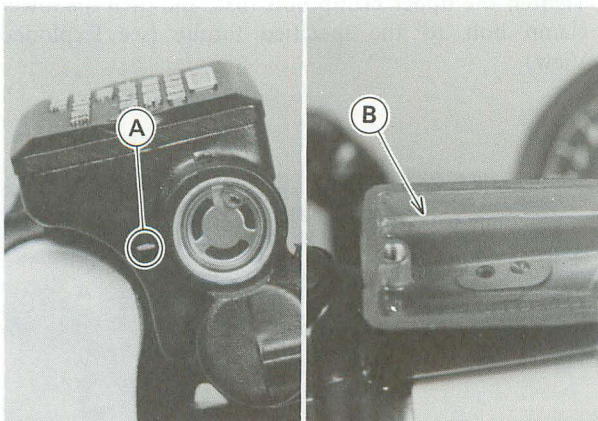

A. Lower Level Line

B. Upper Level Line

NOTE

- Hold the reservoir horizontal when checking clutch fluid level.

- ★ If the fluid level is lower than the lower level line, fill the reservoir to the upper level line in the reservoir.

WARNING

- Change the fluid in the clutch line completely if the fluid must be refilled but the type and brand of the fluid that already is in the reservoir are unidentified. After changing the fluid, use only the same type and brand of fluid thereafter. Mixing different types and brands of fluid lowers the fluid boiling point and could cause the clutch to be ineffective. It may also cause the rubber clutch parts to deteriorate.

Recommended Clutch Fluid

- Grade: D.O.T.4 Heavy Duty Brake Fluid
 Brand: Castrol Girling-Universal
 Castrol GT (LMA)
 Castrol Disc Brake Fluid
 Check Shock Premium Heavy Duty

NOTE

- Since the clutch fluid is the same as the brake fluid, refer to Brake Fluid Section in Brakes for further details.

Clutch Fluid Changing

- Remove the reservoir cap, and remove the rubber cap on the bleed valve.
- Attach a clear plastic hose to the bleed valve on the clutch slave cylinder, and run the other end of the hose into a container.
- Fill the reservoir with fresh fluid.
- Check the clutch fluid as follows.

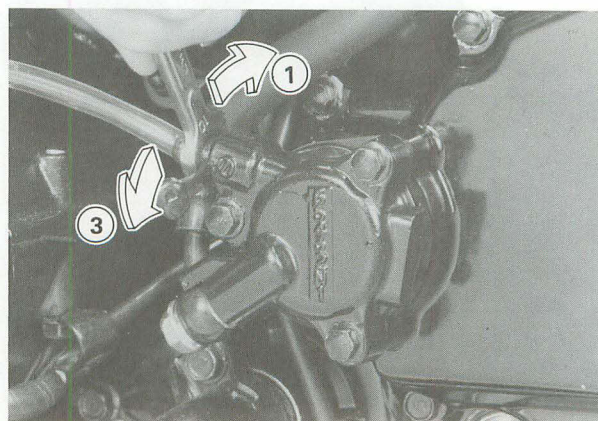
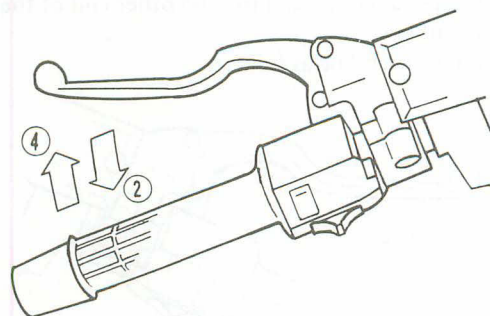

1. Open the bleed valve.
2. Squeeze the clutch lever and hold it.
3. Close the bleed valve.
4. Release the clutch lever.

- Repeat this operation until fresh fluid comes out from the plastic hose or the color of the fluid changes.
- Check the fluid level in the reservoir often, replenishing it as necessary.

NOTE

- If the fluid in the reservoir runs completely out any time during fluid changing, the bleeding operation must be done over again from the beginning since air will have entered the line.

WARNING

- Do not mix two brands of fluid.

5-6 CLUTCH

Bleeding the Clutch Line

- With the reservoir cap off, slowly pump the clutch lever several times until no air bubbles can be seen rising up through the fluid from the holes at the bottom of the reservoir. This bleeds the air from the master cylinder end of the line.

NOTE

- Tap the clutch hose lightly going from the lower end to the upper end and bleed the air off at the reservoir.
- Attach a clear plastic hose to the bleed valve on the clutch slave cylinder, and run the other end of the hose into a container.
- Bleed the clutch line as follows:

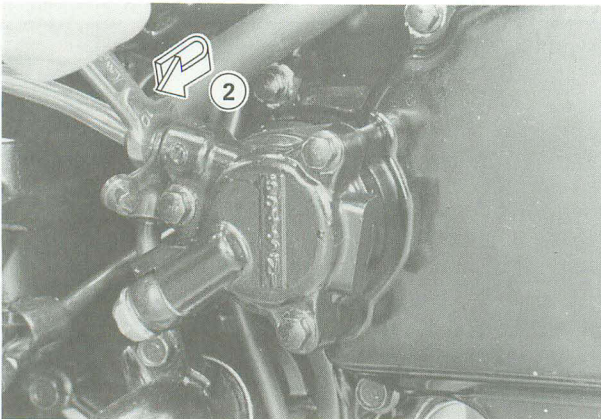
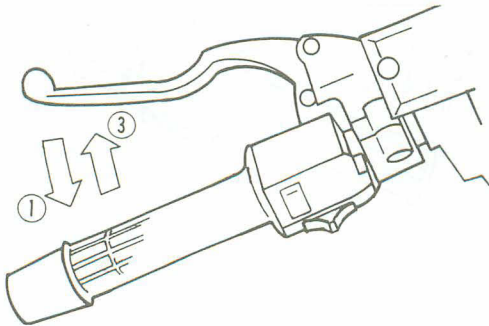

1. Pump the clutch lever a few times until it becomes hard and then hold it squeezed.
2. Quickly open and close the bleed valve.
3. Release the clutch lever.

- Check the fluid level in the reservoir often, replenishing it as necessary.

NOTE

- If the fluid in the reservoir runs completely out any time during bleeding, the bleeding operation must be done over again from the beginning since air will have entered the line.
- Repeat this operation until no more air can be seen coming out in to the plastic hose.

WARNING

- Do not mix two brands of fluid.

Master Cylinder

Installation

- When installing the clutch master cylinder, be careful of following.
- The master cylinder clamp with the arrow on it pointing upwards.
- Tighten the upper clamp bolt first, and then the lower clamp bolt to the specified torque (see Exploded View).

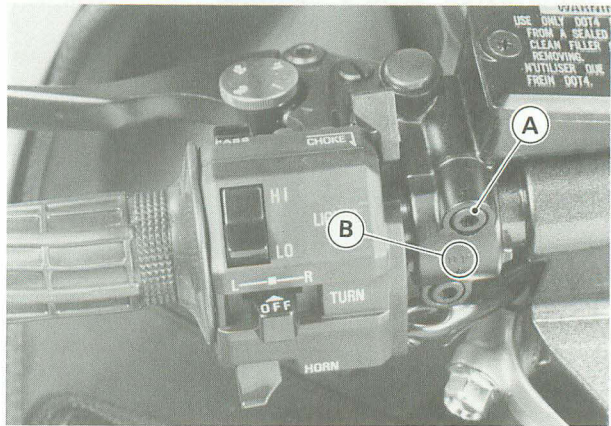

- A. Tighten upper clamp bolt first.
- B. UP mark

- Replace the aluminum washer on each side of the clutch hose fitting with a new one.
- Tighten the banjo bolt to the specified torque (see Exploded View).

- Perform the following after installing the master cylinder.

- Bleed for clutch line
- Check for clutch operation
- Check for fluid leakage

Disassembly

- Remove the following.
 - Clutch Lever
 - Dust Cover
 - Circlip
 - Piston and Secondary Cup, Primary Cup
 - Spring

NOTE

- Do not remove the secondary cup from the piston.

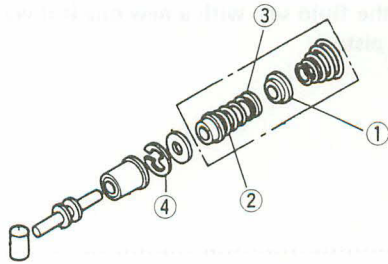

- 1. Primary Cup
- 2. Secondary Cup
- 3. Piston
- 4. Circlip

Assembly

- Clean the disassembled parts with clutch fluid and apply clutch fluid to the inner wall of the cylinder.

CAUTION

- Take care not to scratch the piston or the inner wall of the cylinder.

Inspection

- Check the following for wear, damage, cracks, or deterioration:
 - Cylinder Inner Wall and Piston
 - Primary and Secondary Cups
 - Dust Cover
 - Spring
- Check that the relief and supply ports on the cylinder are not plugged.

Clutch Slave Cylinder

Removal

- Remove the following.
 - Banjo Bolt
 - Mounting Bolts

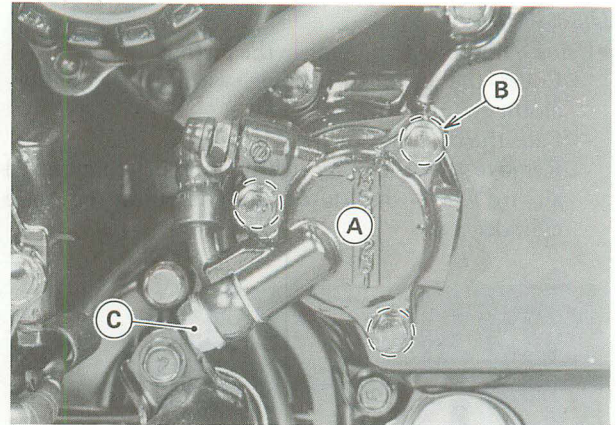

- A. Slave Cylinder
- B. Mounting Bolts
- C. Banjo Bolt

CAUTION

- Immediately wipe up any brake fluid that spills. It may damage painted surfaces.
- Perform the following if the clutch slave cylinder is to be removed but not disassembled.

CAUTION

- If the clutch slave cylinder is removed and left alone, the piston will be pushed out by the spring and the clutch fluid will drain out.
- Remove the clutch slave cylinder from the engine with the hose and push the piston into the cylinder as far as it will go.
- Squeeze the clutch lever slowly and hold it with a band.

NOTE

- Holding the clutch lever keeps the piston from coming out.

Installation

- Note the following.
 - Replace the aluminum washers on each side of the clutch hose fitting with new ones.
 - Tighten the banjo bolt to the specified torque (see Exploded View).
 - Replace the spacer of the clutch slave cylinder with new one.
 - Apply non-permanent locking agent to the two short bolts of the slave cylinder mounting bolts.
 - Check the fluid level in the master cylinder reservoir, and bleed the air in the clutch line.
 - Check the clutch operation.

5-8 CLUTCH

Disassembly

- Using compressed air, remove the piston.
 - Cover the cylinder opening with a clean, heavy cloth.
 - Face the opening downwards.
 - Remove the piston by lightly applying compressed air to where the clutch line fits into the slave cylinder.

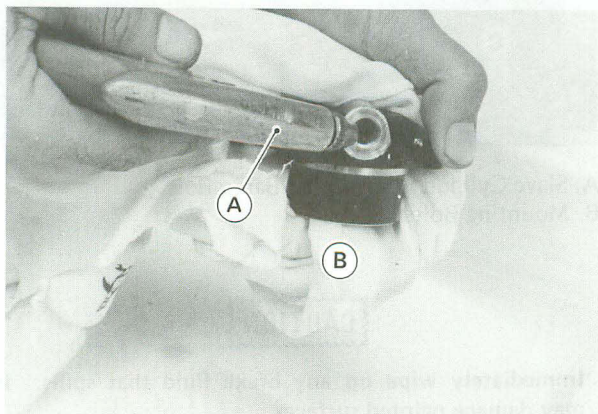

A. Apply compressed air. B. Cloth



- If the fluid seal is removed from the piston, replace the seal with a new one. Removal would damage the seal.



- To avoid serious injury, never place your fingers or palm in front of the cylinder opening. If you apply high compressed air to the cylinder, the piston may injure your hand or fingers.

Assembly

- Do the following.
 - Apply clutch fluid to the outside of the piston and the fluid seal.
 - Install the fluid seal as shown in the figure.

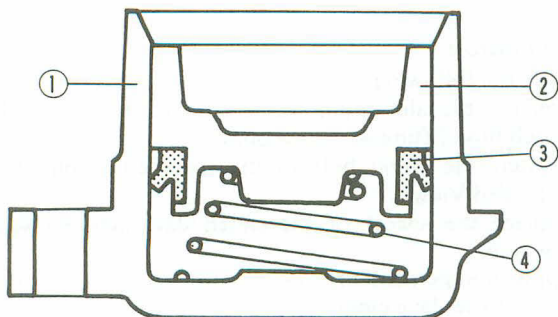

1. Cylinder 3. Fluid Seal
2. Piston 4. Spring



- Replace the fluid seal with a new one if it was removed from the piston.

Clutch

Removal

- Remove the following.
 - Fairings
 - Clutch Cover

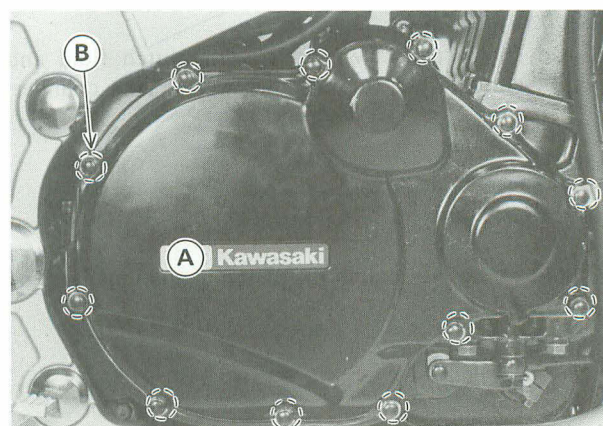

A. Clutch Cover B. Bolts

- Clutch Spring Bolts
- Clutch Springs
- Clutch Spring Plate (with thrust bearing and pusher)

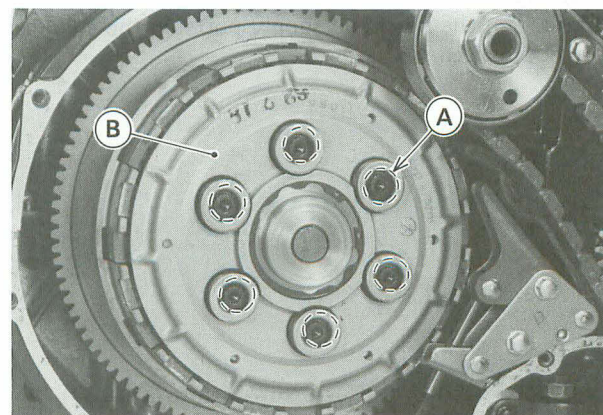

A. Clutch Spring Bolts B. Clutch Spring Plate

- Friction Plates, Steel Plates
- Clutch Hub
- Using the clutch Hub Holder (special tool), hold the clutch hub to remove the nut.

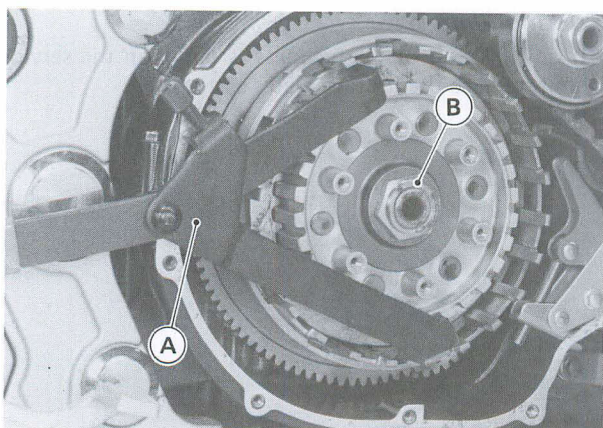

A. Clutch Hub Holder: 57001-1243
 B. Clutch Hub Nut

NOTE

○When removing the clutch housing, remove the alternator drive chain tensioner for easy handling (see Crankshaft/Transmission chapter).

Sleeve
 Clutch Housing

○Using the two 6 mm bolts, pull out the sleeve.

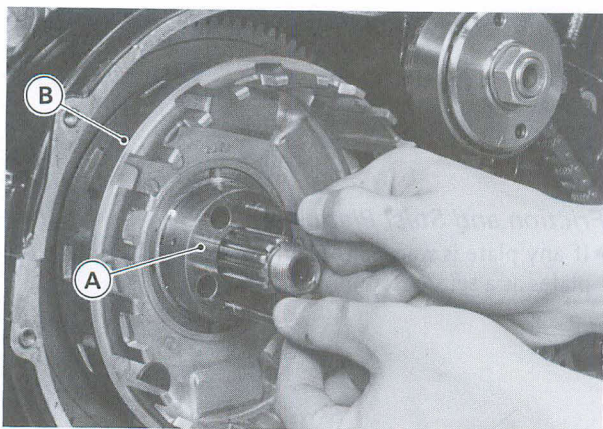

A. Sleeve
 B. Clutch Housing

Installation

- Installation is the reverse of removal. Note the following.
- Discard the used clutch hub self-locking nut, and install a new nut.

CAUTION

○If new dry friction plates and steel plates are installed, apply engine oil to the surfaces of each plate to avoid clutch plate seizure.

●Install the friction plates as shown in the figure.

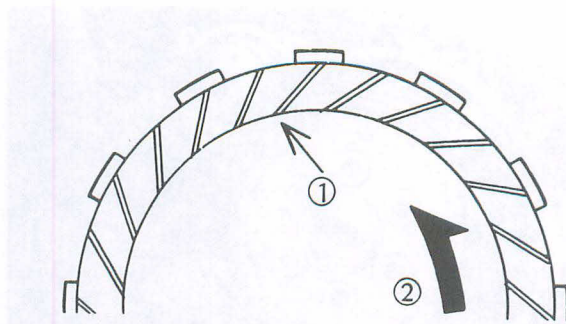

1. Oil Groove
 2. Direction of Rotation

○Install the last friction plate fitting the tangs in the groove on the housing as shown.

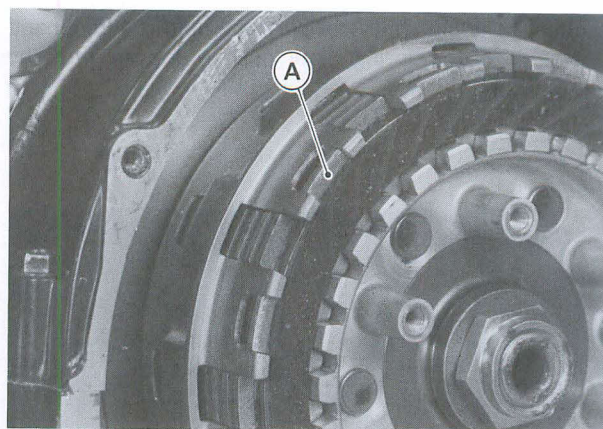

A. Last Friction Plate

- Install the alternator drive chain tensioner, if it was removed (see Crankshaft/Transmission chapter).
- Tighten the following fasteners to the specified torque (see Exploded View).
 Clutch Hub Nut
 Clutch Spring Bolts
- Apply molybdenum disulfide grease to the push rod end.

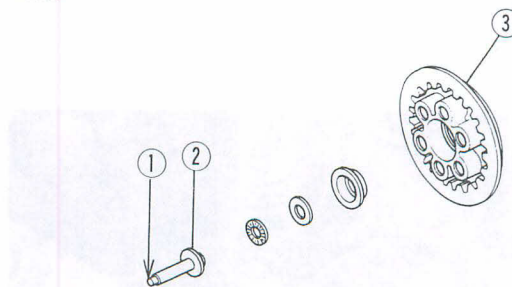

1. Apply molybdenum disulfide grease.
2. Push Rod
3. Clutch Spring Plate

●Apply silicone sealant to the crankcase halves mating surface on the front and rear sides of the cover mount.

5-10 CLUTCH

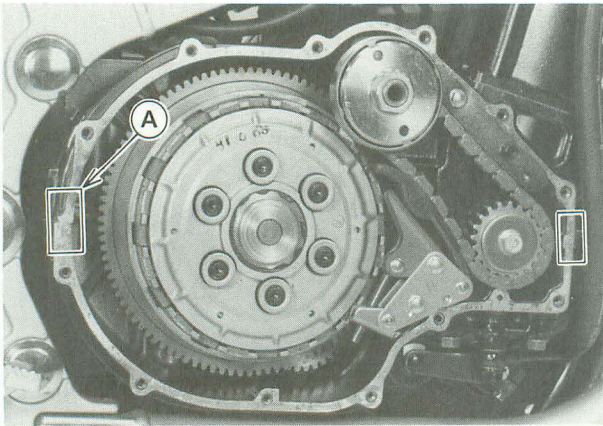

A. Silicone Sealant Applied Areas

- Squeeze the clutch lever slowly and hold it with a band while push the spring plate push rod push into the clutch hub.

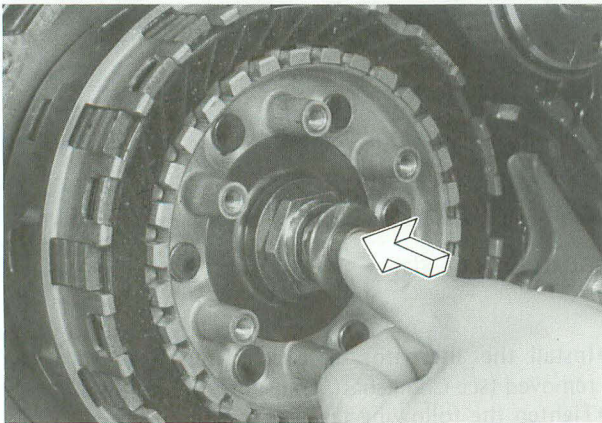

- Apply a non-permanent locking agent to the following bolts.

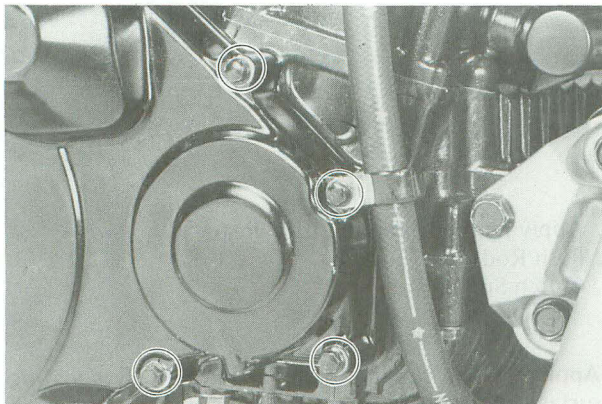

Friction Plate Wear

- ★ If any friction plate thickness is less than the service limit, replace the friction plates as a set.

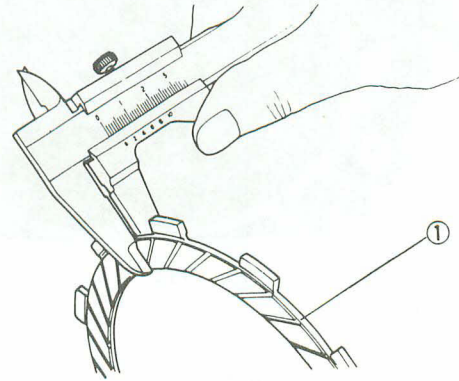

1. Friction Plate

Friction Plate Thickness

Standard:	2.9 – 3.1 mm
Service Limit:	2.8 mm

Friction and Steel Plate Warp

- ★ If any plate is warped over the service limit, replace the plates as a set.

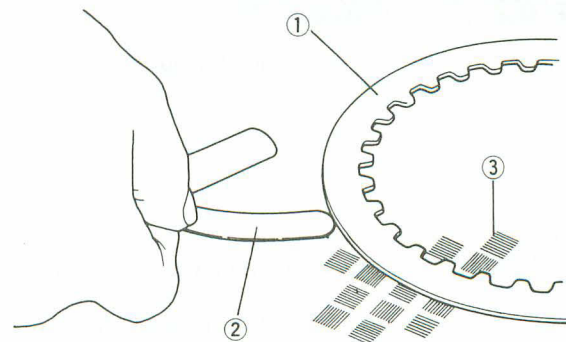

1. Friction or Steel Plate 3. Surface Plate
2. Thickness Gauge

Friction and Steel Plate Warp

Standard:	less than 0.2 mm
Service Limit:	0.3 mm

Clutch Spring Free Length Measurement

★If any of the spring is shorter than the service limit, it must be replaced.

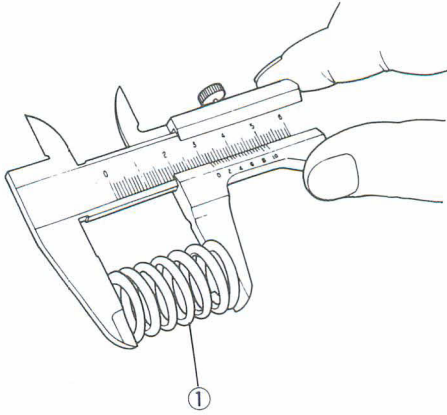

1. Clutch Spring

Clutch Spring Free Length

Standard:	33.2 mm
Service Limit:	32.1 mm

Engine Lubrication System

Table of Contents

Exploded View	6-2
Engine Oil Flow Chart	6-4
Specifications	6-5
Special Tools	6-5
Engine Oil and Filter	6-6
Oil Level Inspection	6-6
Engine Oil Change	6-6
Oil Filter Change	6-7
Oil Pan	6-7
Removal	6-7
Installation	6-7
Oil Pump and Relief Valve	6-8
Oil Pump and Relief Valve Removal	6-8
Oil Pump and Relief Valve Installation	6-9
Oil Pump Assembly Note	6-9
Oil Cooler	6-10
Removal	6-10
Installation	6-10
Oil Pressure Measurement	6-10
Relief Valve Opening Pressure Measurement	6-10
Oil Pressure Measurement	6-11

6-2 ENGINE LUBRICATION SYSTEM

Exploded View

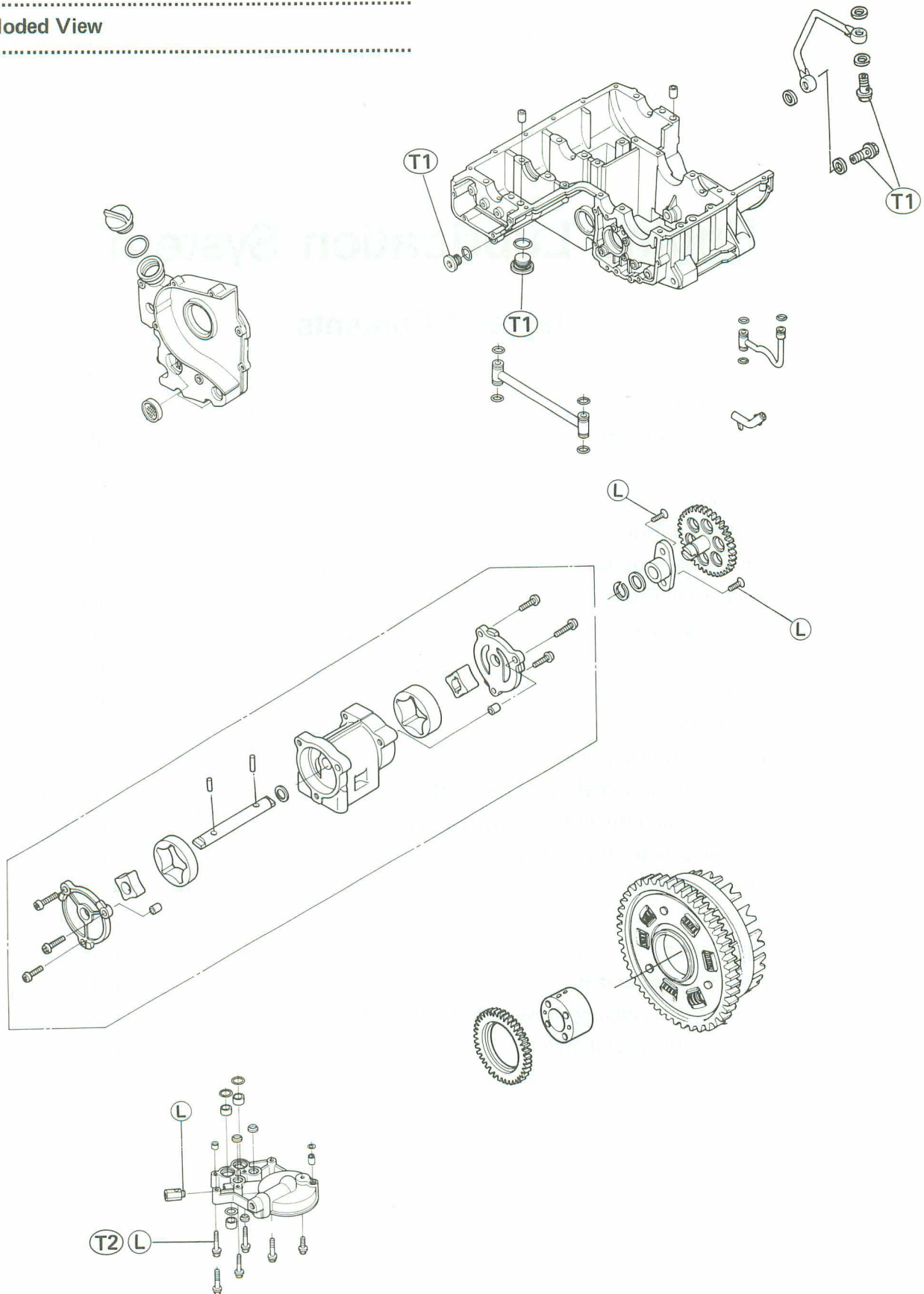

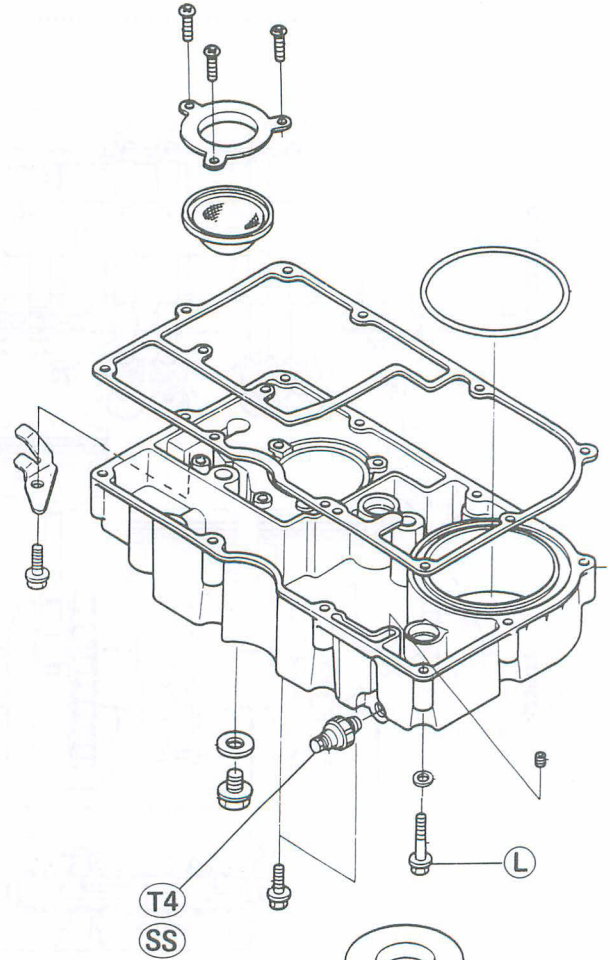
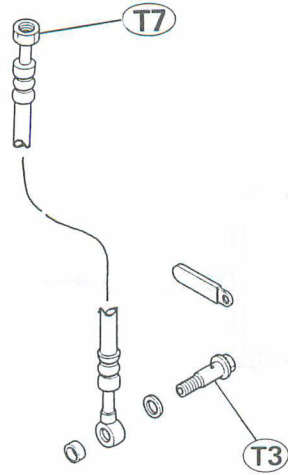

- T1: 18 N-m (1.8 kg-m, 13.0 ft-lb)
- T2: 12 N-m (1.2 kg-m, 104 in-lb)
- T3: 25 N-m (2.5 kg-m, 18.0 ft-lb)
- T4: 15 N-m (1.5 kg-m, 11.0 ft-lb)
- T5: 34 N-m (3.5 kg-m, 25 ft-lb)
- T6: 20 N-m (2.0 kg-m, 14.5 ft-lb)
- T7: 29 N-m (3.0 kg-m, 22 ft-lb)
- L : Apply a non-permanent locking agent.
- SS : Apply silicone sealant.

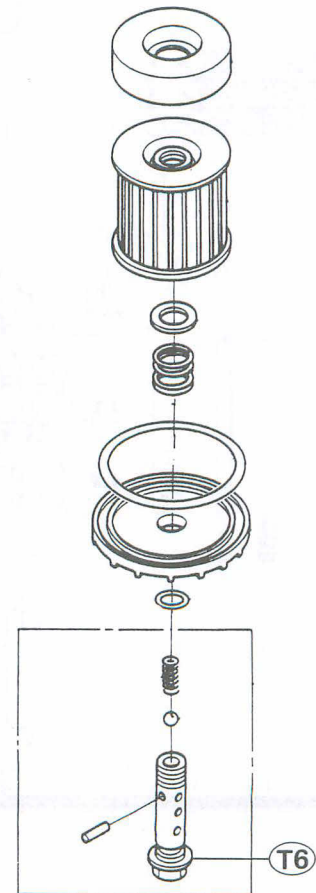
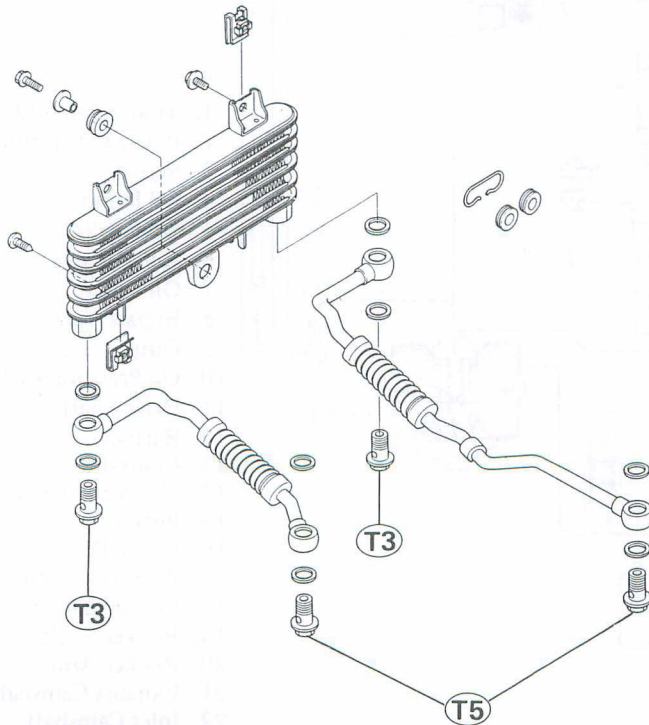

6-4 ENGINE LUBRICATION SYSTEM

Engine Oil Flow Chart

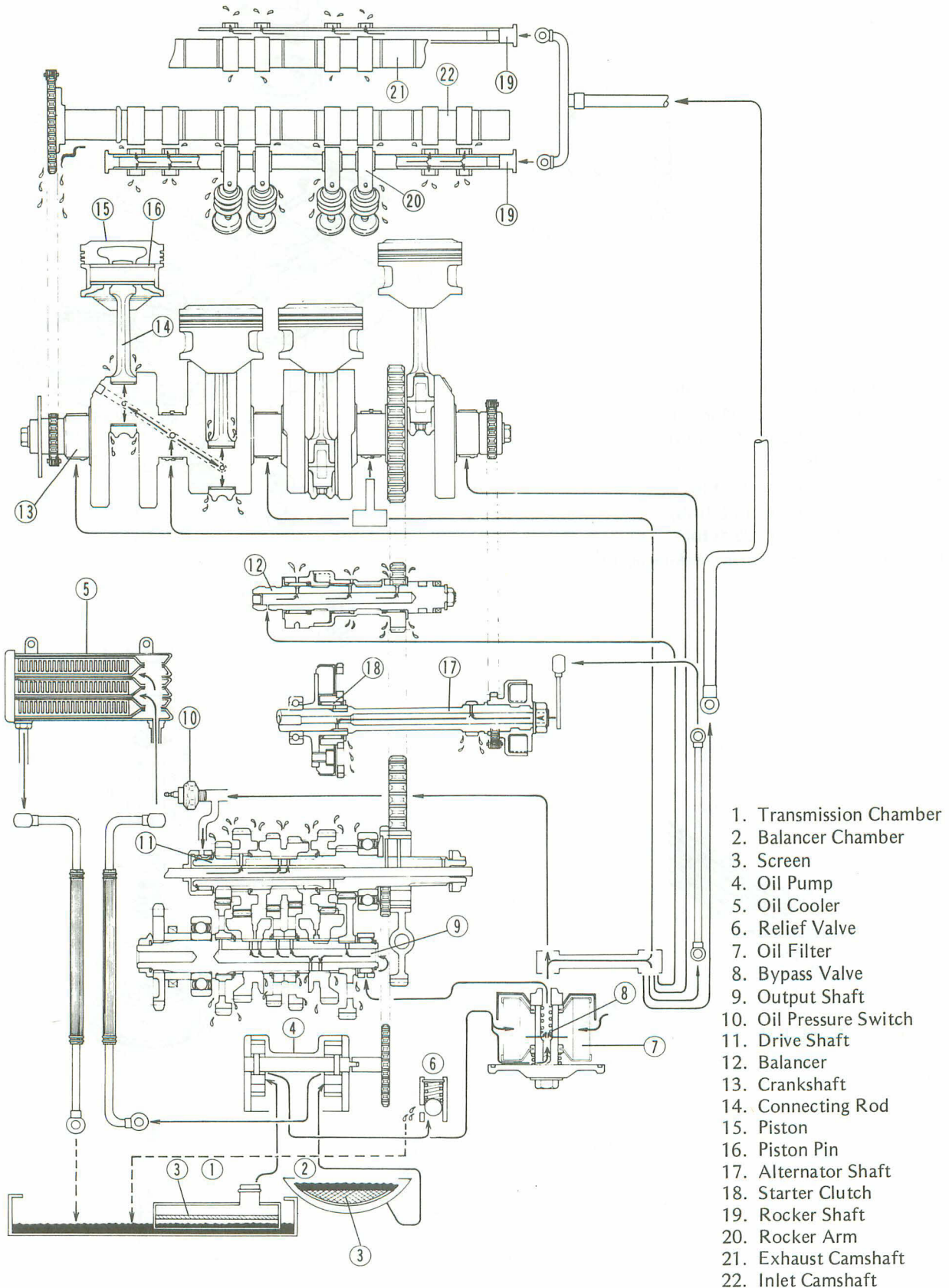

1. Transmission Chamber
2. Balancer Chamber
3. Screen
4. Oil Pump
5. Oil Cooler
6. Relief Valve
7. Oil Filter
8. Bypass Valve
9. Output Shaft
10. Oil Pressure Switch
11. Drive Shaft
12. Balancer
13. Crankshaft
14. Connecting Rod
15. Piston
16. Piston Pin
17. Alternator Shaft
18. Starter Clutch
19. Rocker Shaft
20. Rocker Arm
21. Exhaust Camshaft
22. Inlet Camshaft

Specifications

Item	Standard
Engine Oil: Grade Viscosity Capacity	SE or SF class SAE 10W40, 10W50, 20W40, or 20W50 2.7 L (when filter is not removed) 3.0 L (when filter is removed) 4.0 L (when engine is completely dry)
Oil Pressure Measurement: Relief valve opening pressure Oil pressure @4,000 r/min (rpm), oil temp. 90°C (194°F)	430 – 590 kPa (4.4 – 6.0 kg/cm ² , 63 – 85 psi) 196 – 294 kPa (2.0 – 3.0 kg/cm ² , 28 – 43 psi)

Special Tools

Oil Pressure Gauge: 57001-164

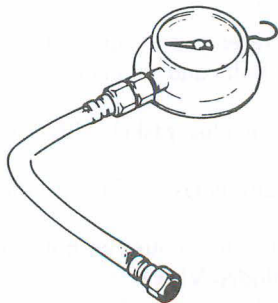

Oil Pressure Gauge Adapter: 57001-1188

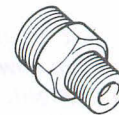

NOTE

○ The oil pressure gauge adapter (P/N 57001-1278) can be used instead of the oil pressure gauge adapter (P/N 57001-1188).

6-6 ENGINE LUBRICATION SYSTEM

Engine Oil and Oil Filter

WARNING

Motorcycle operation with insufficient, deteriorated, or contaminated engine oil will cause accelerated wear and may result in engine or transmission seizure, accident, and injury.

Oil Level Inspection

Check the engine oil level between the upper and lower level in the gauge.

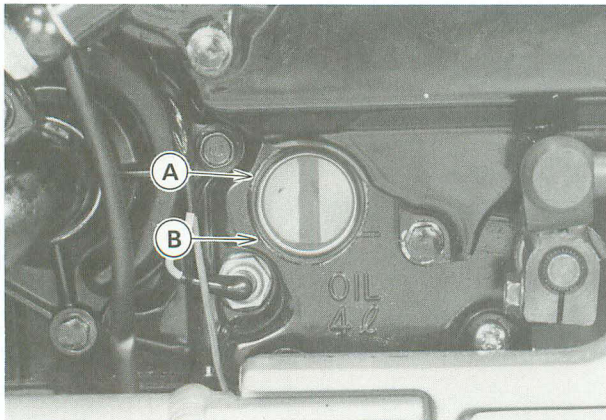

A. Upper Level

B. Lower Level

NOTE

- Situate the motorcycle so that it is perpendicular to the ground.
- If the motorcycle has just been used, wait several minutes for all the oil to drain down.
- If the oil has just been changed, start the engine and run it for several minutes at idle speed. This fills the oil filter with oil. Stop the engine, then wait several minutes until the oil settles.

CAUTION

- Racing the engine before the oil reaches every part can cause engine seizure.
- If the engine oil gets extremely low or if the oil pump or oil passages clog up or otherwise do not function properly, the oil pressure warning light will light. If this light stays on when the engine is running above idle speed, stop the engine immediately and find the cause.

Engine Oil Change

- Set the motorcycle up on its center stand after warming up the engine.
- Remove the lower fairing.
- Remove the engine drain plugs to drain the oil.

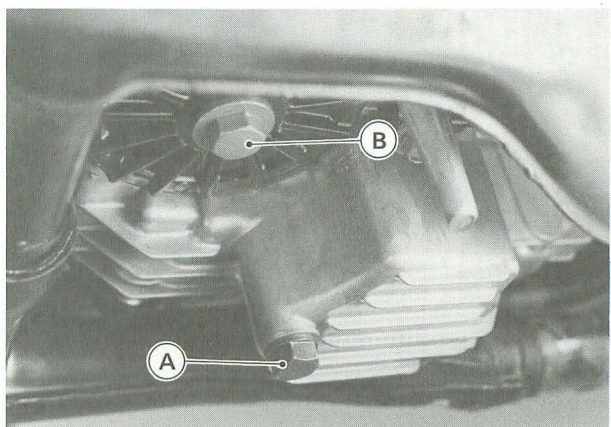
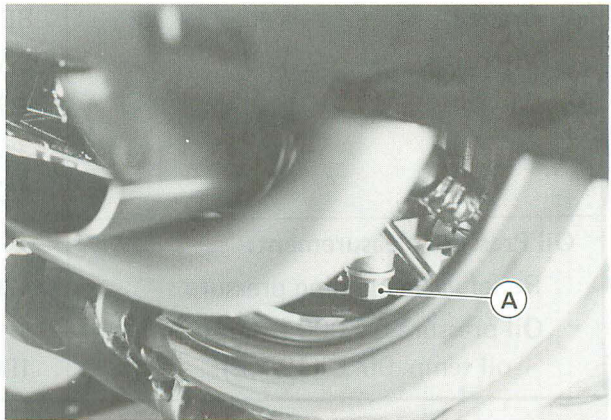

A. Drain Plugs

B. Oil Filter Mounting Bolt

- The oil in the filter can be drained by removing the filter mounting bolts and taking off the filter from the bolt.
- Replace the drain plug gasket with a new one if it is damaged.
- Tighten the drain plugs to the specified torque (see Exploded View).
- Tighten the oil filter mounting bolt to the specified torque (see Exploded View).
- Pour in the specified type and amount of oil.

Engine Oil

- Grade: SE or SF class
- Viscosity: SAE 10W40, 10W50, 20W40, or 20W50
- Amount: 4.0 L (engine is completely dry)
3.0 L (filter is removed)
2.7 L (filter is not removed)

Oil Filter Change

- Drain the engine oil.
- Remove the oil filter mounting bolt and take off the filter assembly.

NOTE

- The oil filter bypass valve is assembled in the mounting bolt.

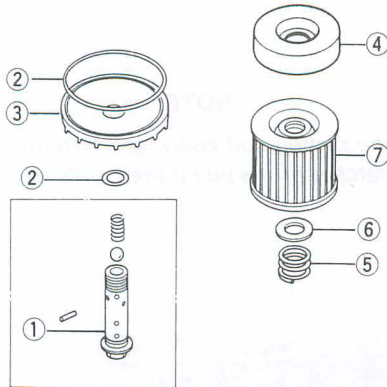

- | | |
|------------------|-----------|
| 1. Mounting Bolt | 5. Spring |
| 2. O-ring | 6. Washer |
| 3. Filter Cover | 7. Filter |
| 4. Oil Fence | |

- When installing the oil filter, be careful of the following.
- Apply oil to the mounting bolt, turn the filter or the mounting bolt to work the filter into place. Be careful that the filter grommets do not slip out of place.
- Tighten the filter mounting bolt to the specified torque (see Exploded View).
- ☆ Replace the O-rings with new ones if they are damaged.
- Pour in the specified type and amount of oil.

Oil Pan

Removal

- Remove the following.
 - Fairings
 - Engine Oil (Drain)
 - Oil Filter
 - Radiator (see Cooling System chapter)
 - Oil Cooler
 - Muffler
 - Oil Pipe and Hose
 - Oil Pressure Switch Lead

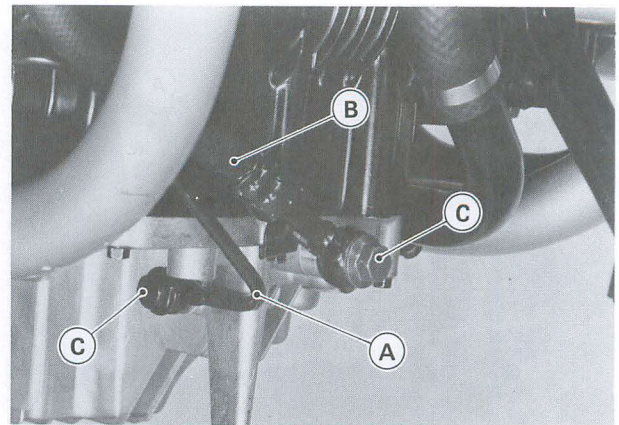

A. Oil Pipe
B. Oil Hose
C. Banjo Bolts

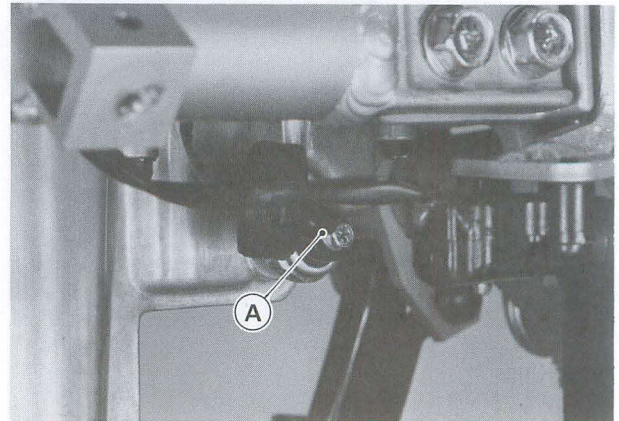

A. Oil Pressure Switch Lead

- Remove the oil pan bolts and take off the oil pan.

Installation

- Installation is the reverse of removal. Note the following.
- Apply a silicone sealant to the threads of the oil pressure switch, and tighten it to the specified torque (see Exploded View).
- Replace the gasket with a new one.
- Replace the O-rings with new ones if they are damaged.
- The outlet side O-ring between the oil pan and the oil pump bracket must be installed so that flat side faces the bracket.

6-8 ENGINE LUBRICATION SYSTEM

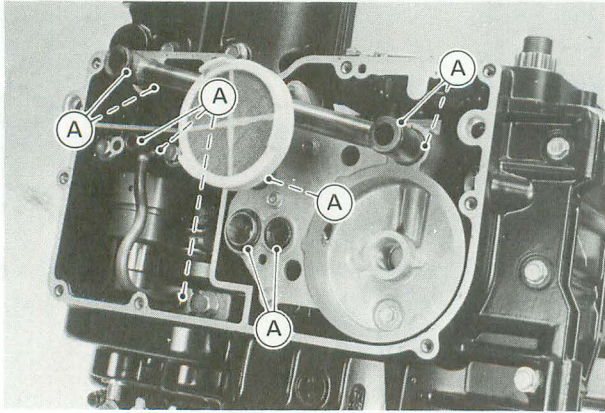

Oil Pump and Relief Valve

Oil Pump and Relief Valve Removal

- Remove the following.
 - Oil Pan
 - Oil Screen
 - Oil Pipe
 - Oil Pump Bracket Bolts
- Pull out the bracket and pump assembly.

NOTE

- Remove the pickup coil cover, and turn the crankshaft until the catches of the pump shaft ends are vertical.

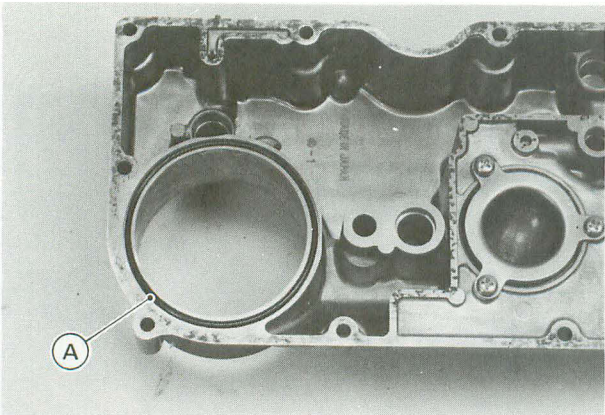

A. O-Rings

- Apply a non-permanent locking agent to the threads of the four oil pan bolts which are indicated by the triangular marks.

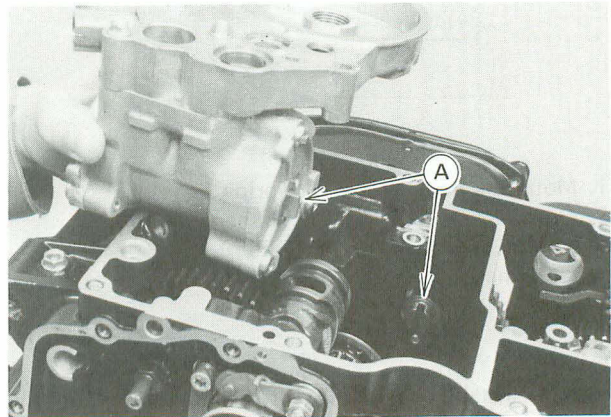

A. Catches

- Remove the oil pump.
- Unscrew the relief valve.

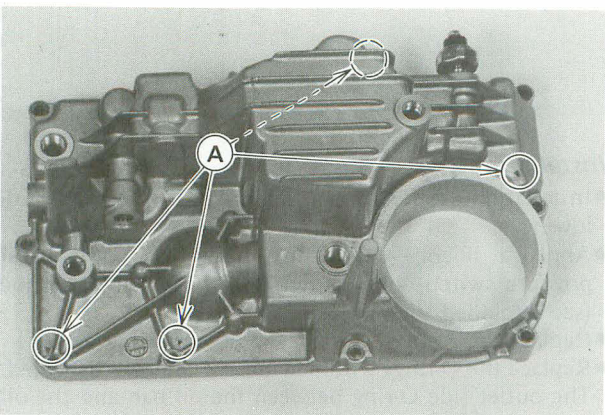

A. Triangular Marks

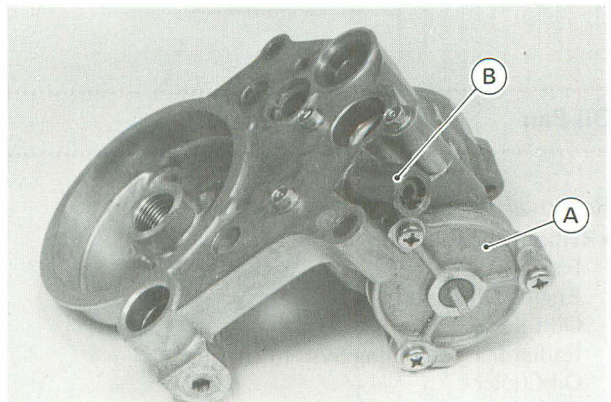

A. Oil Pump
B. Relief Valve

Oil Pump and Relief Valve Installation

- Fill the pump with engine oil before installation.
- Check that the collars and O-rings are in place. The outlet side O-rings must be installed so that the flat side faces the bracket.

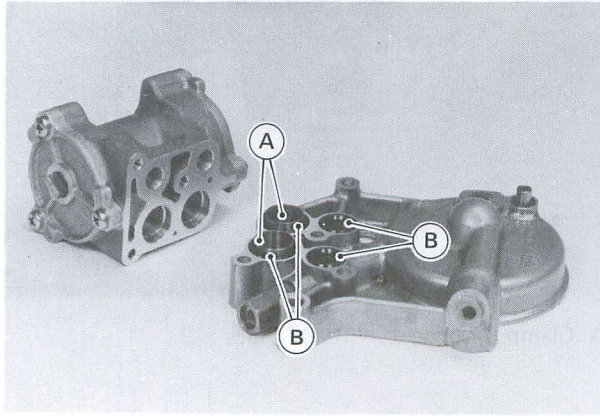

A. Collars B. O-Rings

- Apply non-permanent locking agent to the following, and torque them to the specified (see Exploded View).
Relief Valve
Oil Pump Mounting Bolts

CAUTION

- Do not over-apply a non-permanent locking agent to the threads. This may block the oil passage.
- Check that the knock pin, nozzle, and O-ring are in place. The small hole of the nozzle must face the bracket.

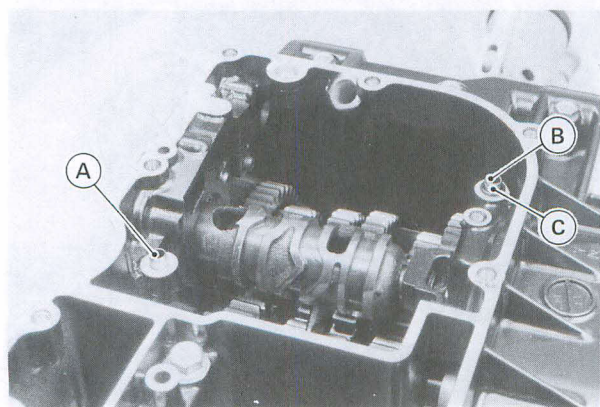

A. Knock Pin B. Nozzle
C. O-ring

- Check that the oil pump shaft catches of both components are vertical.

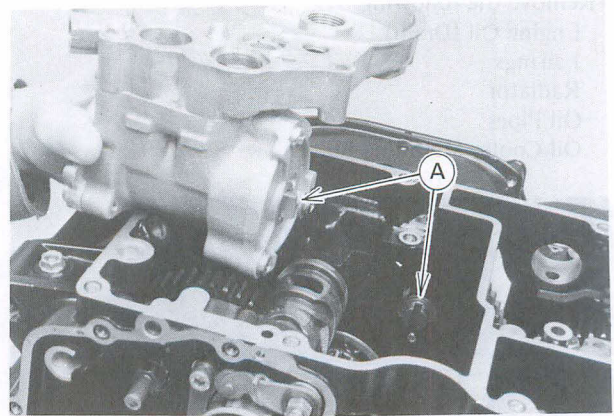

A. Catches

Oil Pump Assembly Note

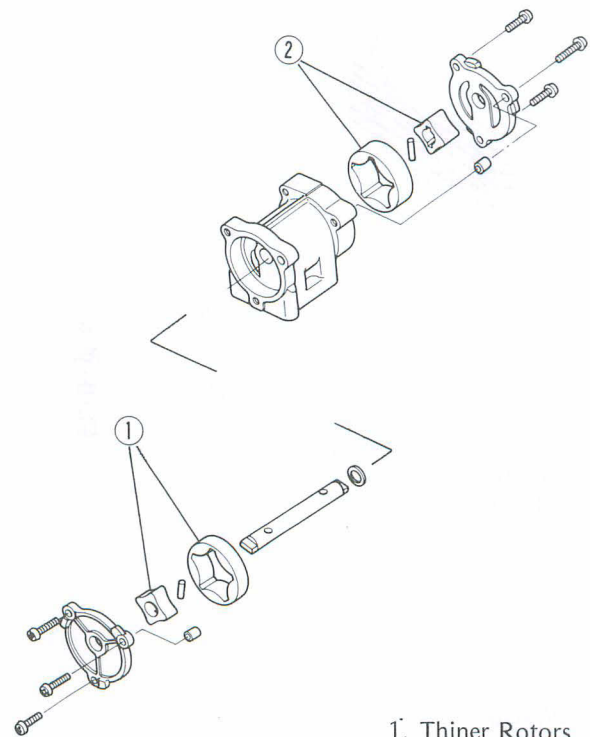

1. Thinner Rotors
2. Thicker Rotors

- Before installing the oil pump, be sure the shaft and rotors turn freely.

6-10 ENGINE LUBRICATION SYSTEM

Oil Cooler

Removal

- Remove the following.
 - Engine Oil (Drain)
 - Fairings
 - Radiator
 - Oil Pipes
 - Oil Cooler Mounting Bolt

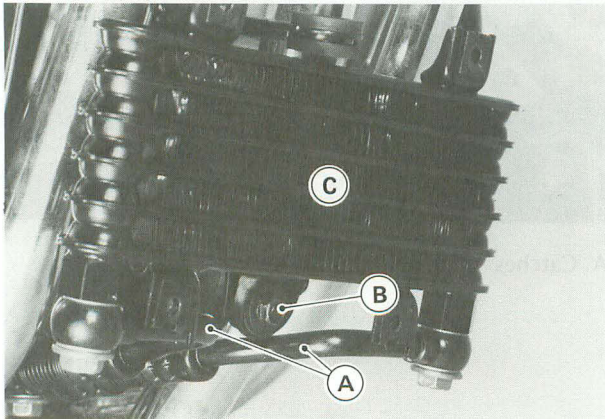

A. Oil Pipes
B. Mounting Bolt
C. Oil Cooler

Oil Cooler Mounting Bolt

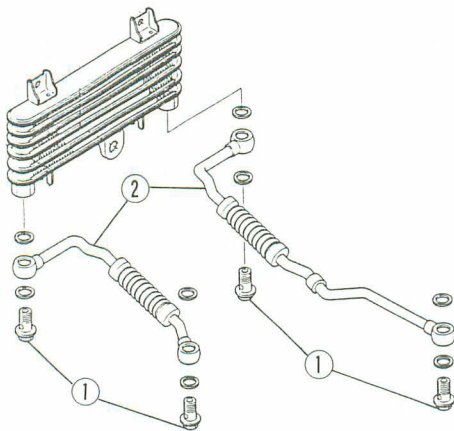

1. Banjo Bolts
2. Oil Pipes

Installation

- Installation is the reverse of removal. Note the following.
- Replace the washer on each side of the hose fitting with a new one if the banjo bolt was removed.
- After installing the oil cooler, tighten the banjo bolts to the specified torque (see Exploded View).

- Install the clamp on the oil pipes so that the clamp opening faces downwards, as shown.

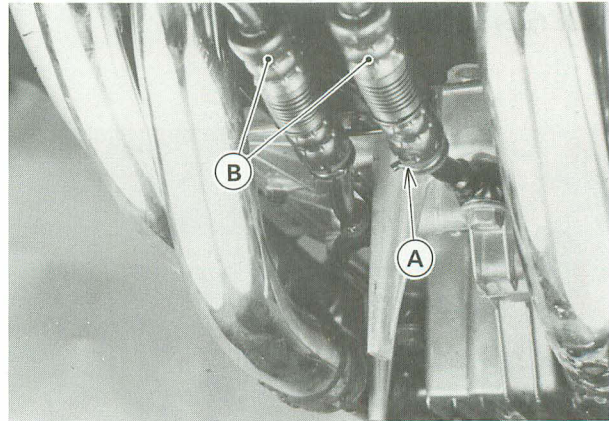

A. Clamp
B. Oil Pipes

Oil Pressure Measurement

Relief Valve Opening Pressure Measurement

NOTE

- Measure the oil pressure before the engine is warmed up if you want to test relief valve opening pressure.

- Remove the oil passage plug.
- Attach the oil pressure gauge and adapter (special tools) to the plug hole.

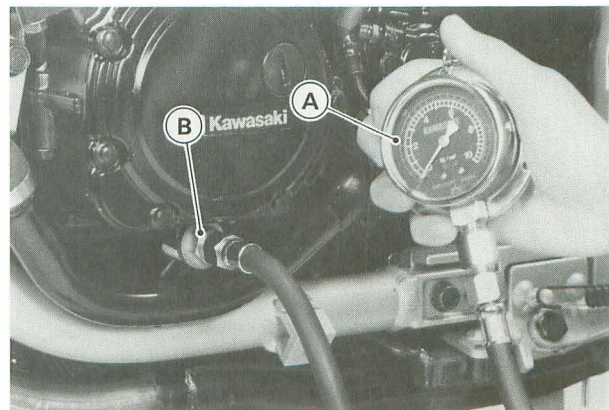

A. Oil Pressure Gauge: 57001-164
B. Adapter: 57001-1188

- Read the maximum oil pressure while running the engine at various speeds. A normal relief valve keeps the maximum oil pressure between the specified valves.

Relief Valve Opening Pressure

Standard: 430 – 590 kPa
(4.4 – 6.0 kg/cm², 63 – 85 psi)

- ★ If the reading is much higher than the standard or is much lower than the standard, find the cause immediately.

Oil Pressure Measurement

NOTE

○ Measure the oil pressure after the engine is warmed up.

- Attached the oil pressure gauge and adapter (special tools) to the oil passage plug hole.

Oil Pressure

Standard: 196 – 294 kPa
(2.0 – 3.0 kg/cm², 28 – 43 psi)
@4 000 r/min (rpm), 90°C (194°F)
of oil temp.

- ★ If the oil pressure is much lower than the standard, check the oil pump, relief valve, and/or crankshaft bearing insert wear immediately.

Engine Removal/Installation

Table of Contents

Exploded View	7-2
Engine Removal/Installation	7-3
Removal	7-3
Installation	7-4

7-2 ENGINE REMOVAL/INSTALLATION

.....
Exploded View
.....

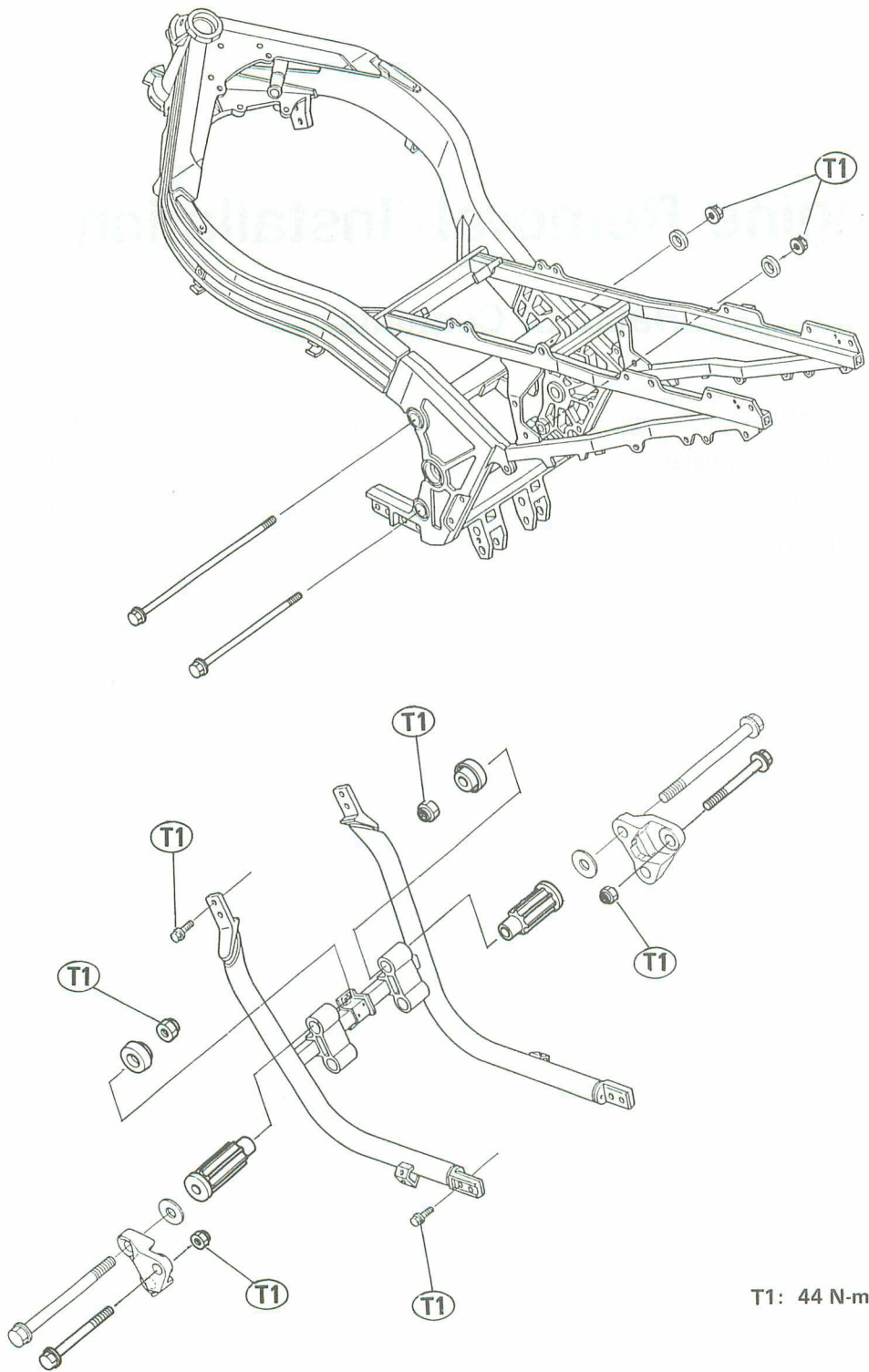

T1: 44 N-m (4.5 kg-m, 33 ft-lb)

Engine Removal/Installation

Engine Removal

- Remove the following.
 - Fairings
 - Engine Oil (Drain)
 - Coolant (Drain)
 - Seat
 - Fuel Tank
 - Radiator
 - Oil Cooler
 - Muffler
 - Air Cleaner Housing
 - Carburetors
 - Fuel Pump and Filter
 - Clutch Slave Cylinder (see Clutch chapter)
 - Engine Sprocket
 - Vacuum Switch Valve and Hoses (US model only)
 - Baffle Plate
- Disconnect wiring from the engine and free them from the clamps.
 - Pickup Coil Lead
 - Battery Ground Lead
 - Starter Motor Lead
 - Oil Pressure Switch Wire
 - Side Stand Switch Leads
 - Alternator Leads
 - Neutral Switch Leads

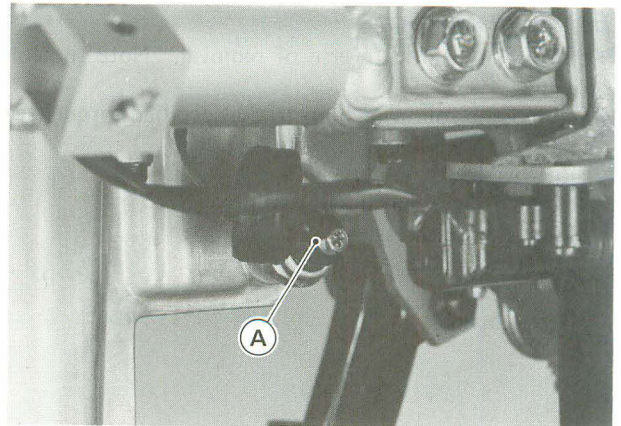

A. Oil Pressure Switch Lead

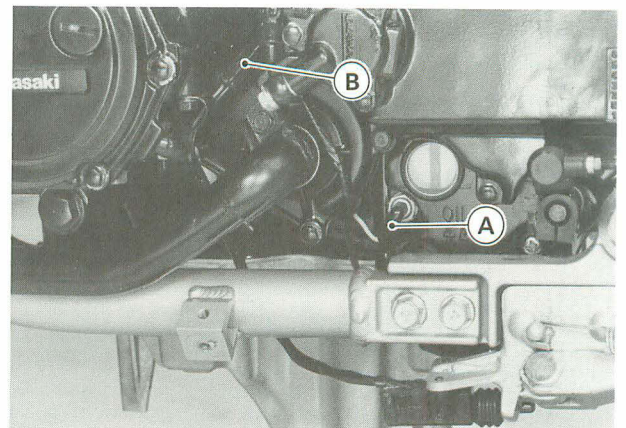

A. Neutral Switch Lead
B. Side Stand Switch Lead Connector

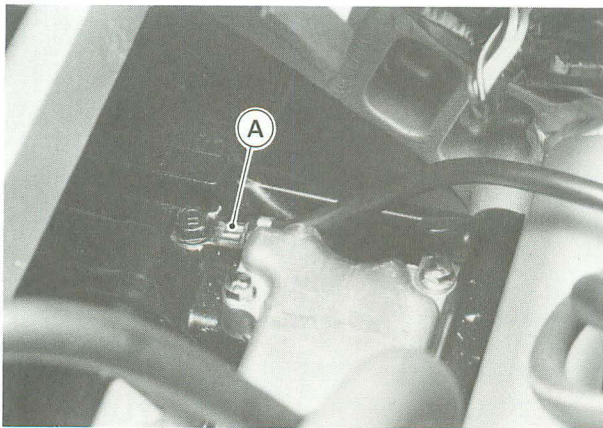

A. Battery Ground Lead

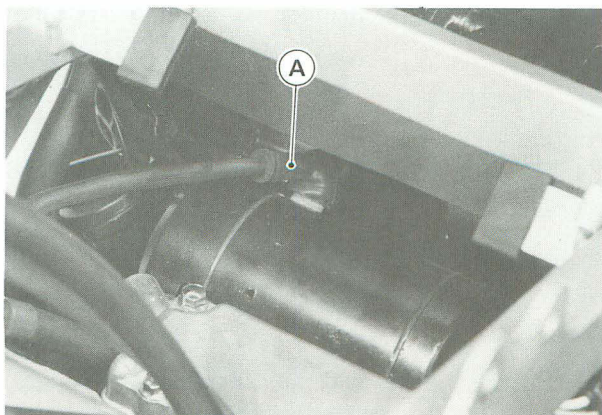

A. Starter Motor Lead

- Remove the down tube.

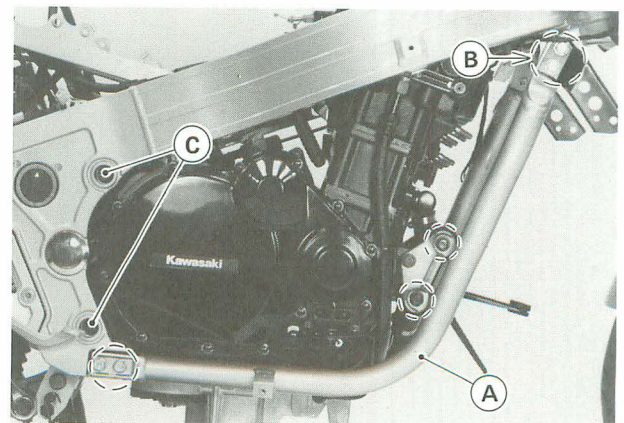

A. Down Tube C. Rear Engine Mounting Bolts
B. Bolts

- Support the engine with a stand before take out the rear engine mounting bolts.
- Remove the engine.

7-4 ENGINE REMOVAL/INSTALLATION

Engine Installation

- Installation is the reverse of removal. Note the following.
- Tighten the following bolts to the specified torque (see Exploded View).
 - Engine Mounting Bolts
 - Down Tube Mounting Bolts
- Adjust the following.
 - Throttle Cable
 - Choke Cable
 - Drive Chain

Crankshaft/Transmission

Table of Contents

Exploded View	8-2
Specifications	8-4
Special Tools	8-5
Crankcase Splitting	8-6
Crankcase Splitting	8-6
Crankcase Assembly	8-6
Crankshaft/Connecting Rods	8-8
Crankshaft Removal	8-8
Crankshaft Installation Notes	8-8
Connecting Rod Removal	8-8
Connecting Rod Installation	8-8
Connecting Rod Big End Bearing Insert/Crankpin Wear	8-9
Crankshaft Main Bearing Insert/Journal Wear	8-11
Crankshaft Side Clearance	8-13
Balancer	8-13
Balancer Removal	8-13
Balancer Installation Notes	8-13
Damper Inspection	8-14
Needle Bearing Wear	8-14
Alternator Shaft/Starter Motor Clutch	8-14
Alternator Chain and Tensioner Removal	8-14
Alternator Chain and Tensioner Installation Note	8-15
Alternator Shaft and Starter Clutch Removal	8-15
Alternator Shaft and Starter Clutch Installation	8-15
Alternator Shaft Chain Wear	8-15
Starter Motor Clutch Inspection	8-16
Transmission	8-16
External Shift Mechanism Removal	8-16
External Shift Mechanism Installation	8-16
External Shift Mechanism Inspection	8-16
Transmission Shaft Removal	8-17
Transmission Shaft Installation	8-17
Transmission Shaft Disassembly	8-17
Transmission Shaft Assembly	8-17
Shift Drum and Fork Removal	8-19
Shift Drum and Fork Installation	8-19

8-2 CRANKSHAFT/TRANSMISSION

Exploded View

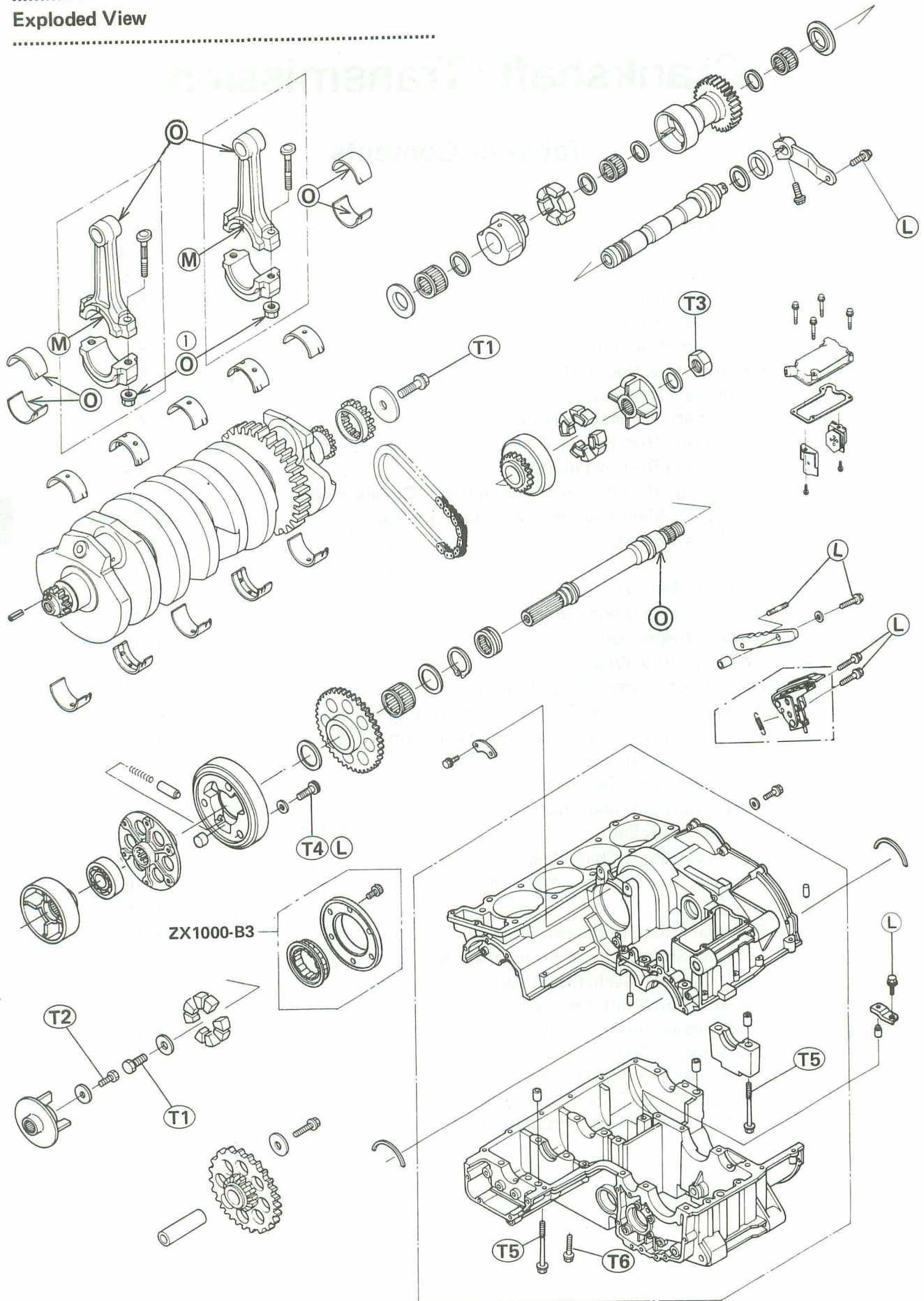

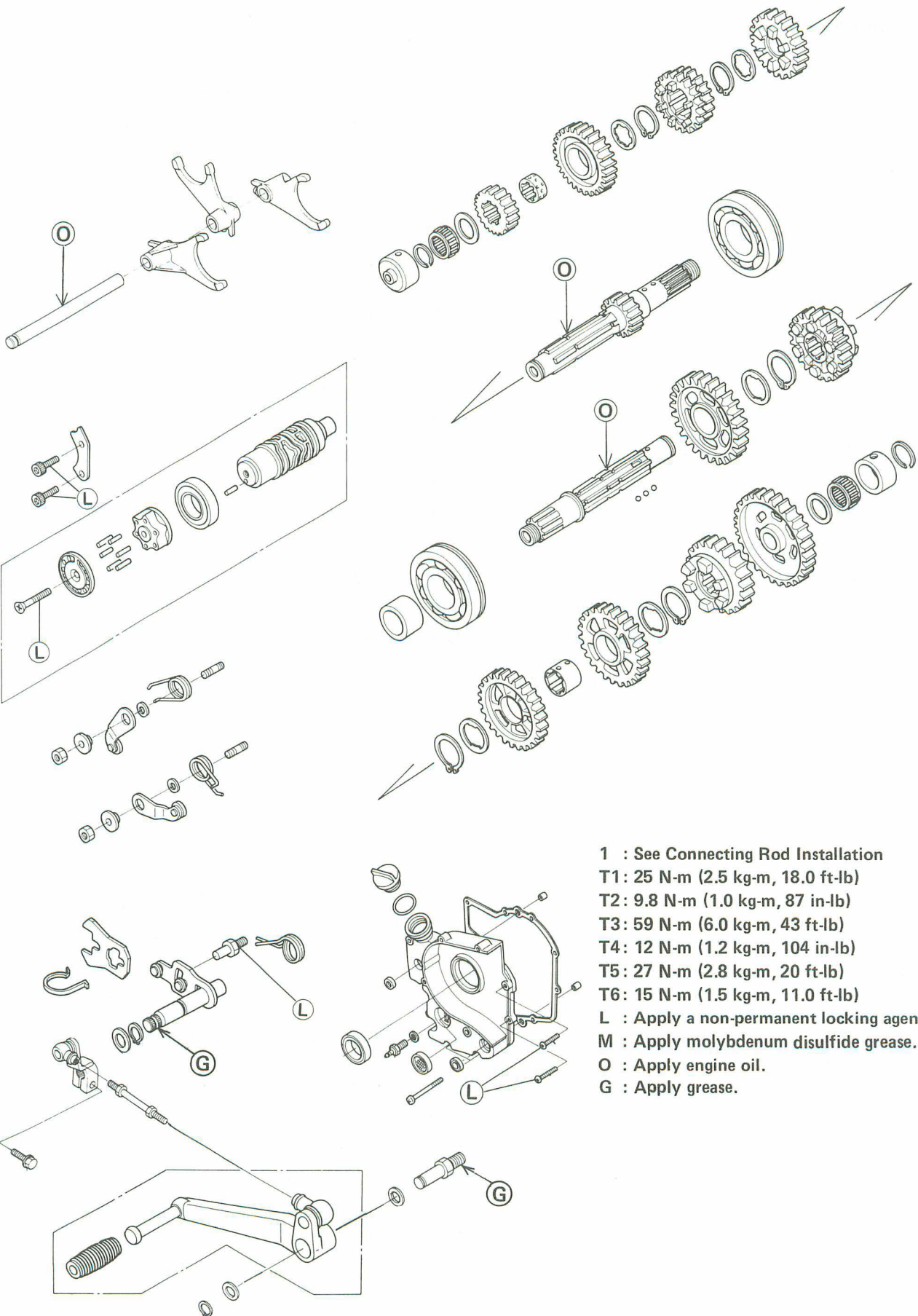

- 1 : See Connecting Rod Installation
- T1: 25 N-m (2.5 kg-m, 18.0 ft-lb)
- T2: 9.8 N-m (1.0 kg-m, 87 in-lb)
- T3: 59 N-m (6.0 kg-m, 43 ft-lb)
- T4: 12 N-m (1.2 kg-m, 104 in-lb)
- T5: 27 N-m (2.8 kg-m, 20 ft-lb)
- T6: 15 N-m (1.5 kg-m, 11.0 ft-lb)
- L : Apply a non-permanent locking agent.
- M : Apply molybdenum disulfide grease.
- O : Apply engine oil.
- G : Apply grease.

8-4 CRANKSHAFT/TRANSMISSION

Specifications

Item	Standard	Service Limit																					
Crankshaft, Connecting Rods:																							
Connecting rod bend	---	0.2/100 mm																					
Connecting rod twist	---	0.2/100 mm																					
Connecting rod big end side clearance	0.13 – 0.33 mm	0.50 mm																					
Connecting rod big end bearing insert/crankpin clearance	0.036 – 0.066 mm	0.10 mm																					
Crankpin diameter:	34.984 – 35.000 mm	34.97 mm																					
Marking	None	---																					
	○	---																					
Connecting rod big end bore diameter:	38.000 – 38.016 mm	---																					
Marking	None	---																					
	○	---																					
Connecting rod big end bearing insert thickness:																							
	Black	---																					
	Blue	---																					
	White	---																					
Connecting rod big end bearing insert selection:																							
<table border="1"> <thead> <tr> <th rowspan="2">Con-rod Big End Bore Diameter Marking</th> <th rowspan="2">Crankpin Diameter Marking</th> <th colspan="2">Bearing Insert</th> </tr> <tr> <th>Size Color</th> <th>Part Number</th> </tr> </thead> <tbody> <tr> <td>○</td> <td>○</td> <td rowspan="2">Blue</td> <td rowspan="2">92028-1407</td> </tr> <tr> <td>None</td> <td>None</td> </tr> <tr> <td>○</td> <td>None</td> <td>White</td> <td>92028-1547</td> </tr> <tr> <td>None</td> <td>○</td> <td>Black</td> <td>92028-1408</td> </tr> </tbody> </table>				Con-rod Big End Bore Diameter Marking	Crankpin Diameter Marking	Bearing Insert		Size Color	Part Number	○	○	Blue	92028-1407	None	None	○	None	White	92028-1547	None	○	Black	92028-1408
Con-rod Big End Bore Diameter Marking	Crankpin Diameter Marking	Bearing Insert																					
		Size Color	Part Number																				
○	○	Blue	92028-1407																				
None	None																						
○	None	White	92028-1547																				
None	○	Black	92028-1408																				
Crankshaft runout	---	0.05 mm TIR																					
Crankshaft main bearing insert/journal clearance	0.020 – 0.044 mm	0.08 mm																					
Crankshaft main journal diameter:	35.984 – 36.000 mm	35.96 mm																					
Marking	None	---																					
	1	---																					
Crankcase main bearing bore diameter:	39.000 – 39.016 mm	---																					
Marking	○	---																					
	None	---																					

Item	Standard	Service Limit																																		
Crankshaft main bearing insert thickness:																																				
Brown	1.490 – 1.494 mm	— — —																																		
Black	1.494 – 1.498 mm	— — —																																		
Blue	1.498 – 1.502 mm	— — —																																		
Crankshaft main bearing insert selection:																																				
<table border="1"> <thead> <tr> <th rowspan="2">Crankcase Main Bearing Bore Diameter Marking</th> <th rowspan="2">Crankshaft Main Journal Diameter Marking</th> <th colspan="3">Bearing Insert*</th> </tr> <tr> <th>Size Color</th> <th>Part Number</th> <th>Journal Nos.</th> </tr> </thead> <tbody> <tr> <td rowspan="2">○</td> <td rowspan="2">1</td> <td rowspan="2">Brown</td> <td>92028-1102</td> <td>2, 4</td> </tr> <tr> <td>92028-1274</td> <td>1, 3, 5</td> </tr> <tr> <td rowspan="2">None</td> <td rowspan="2">None</td> <td rowspan="2">Blue</td> <td>92028-1100</td> <td>2, 4</td> </tr> <tr> <td>92028-1272</td> <td>1, 3, 5</td> </tr> <tr> <td rowspan="2">○</td> <td rowspan="2">None</td> <td rowspan="2">Black</td> <td>92028-1101</td> <td>2, 4</td> </tr> <tr> <td>92028-1273</td> <td>1, 3, 5</td> </tr> <tr> <td>None</td> <td>1</td> <td></td> <td></td> <td></td> </tr> </tbody> </table>			Crankcase Main Bearing Bore Diameter Marking	Crankshaft Main Journal Diameter Marking	Bearing Insert*			Size Color	Part Number	Journal Nos.	○	1	Brown	92028-1102	2, 4	92028-1274	1, 3, 5	None	None	Blue	92028-1100	2, 4	92028-1272	1, 3, 5	○	None	Black	92028-1101	2, 4	92028-1273	1, 3, 5	None	1			
Crankcase Main Bearing Bore Diameter Marking	Crankshaft Main Journal Diameter Marking	Bearing Insert*																																		
		Size Color	Part Number	Journal Nos.																																
○	1	Brown	92028-1102	2, 4																																
			92028-1274	1, 3, 5																																
None	None	Blue	92028-1100	2, 4																																
			92028-1272	1, 3, 5																																
○	None	Black	92028-1101	2, 4																																
			92028-1273	1, 3, 5																																
None	1																																			
*The bearing inserts for Nos. 2 and 4 journals have oil grooves.																																				
Crankshaft side clearance	0.05 – 0.20 mm	0.40 mm																																		
Alternator shaft chain 20-link length	158.8 – 159.2 mm	161.5 mm																																		
Transmission:																																				
Gear backlash	0.06 – 0.23 mm	0.3 mm																																		
Gear shift fork groove width	5.05 – 5.15 mm	5.3 mm																																		
Shift fork ear thickness	4.9 – 5.0 mm	4.8 mm																																		
Shift fork guide pin diameter	7.9 – 8.0 mm	7.8 mm																																		
Shift drum groove width	8.05 – 8.20 mm	8.3 mm																																		

.....
Special Tools

Coupling Holder: 57001-1189

Circlip Pliers: 57001-144

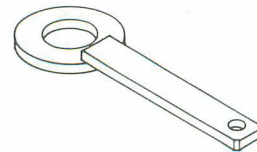
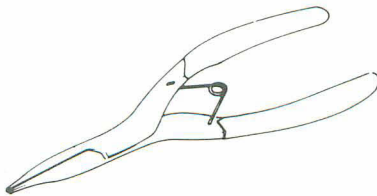

Liquid Gasket: 92104-1003

Silicone Sealant: 56019-120

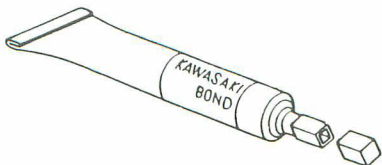

8-6 CRANKSHAFT/TRANSMISSION

Crankcase Splitting

Crankcase Splitting

- Remove the engine (see Engine Removal/Installation chapter).
- Set the engine on a clean surface and hold the engine steady while parts are being removed.
- Remove the following parts from the engine.
 - External Shift Mechanism Cover
 - Starter Motor
 - Alternator
 - Pickup Coil
 - Right Engine Cover
 - Alternator Chain Tensioner
 - Oil Pan
 - Oil Pump with Bracket

Remove the following parts only if the crankshaft is to be removed.

- Cylinder Head
- Cylinder Block
- Pistons

Alternator Shaft Chain and Sprockets

Remove the following part only if the transmission drive shaft assembly is to be removed.

- Clutch

- Remove the upper crankcase bolts.

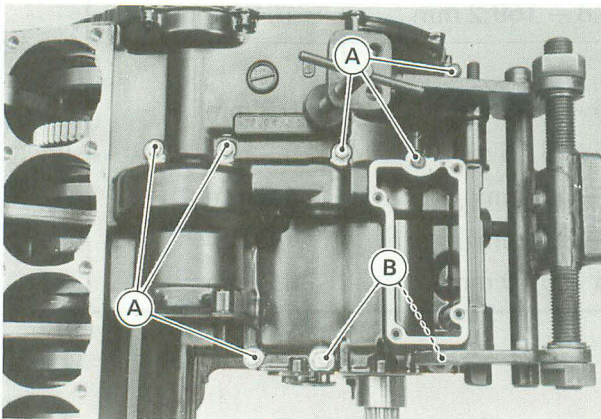

A. 6 mm Bolts B. 8 mm Bolts

- Remove the lower crankcase bolts.

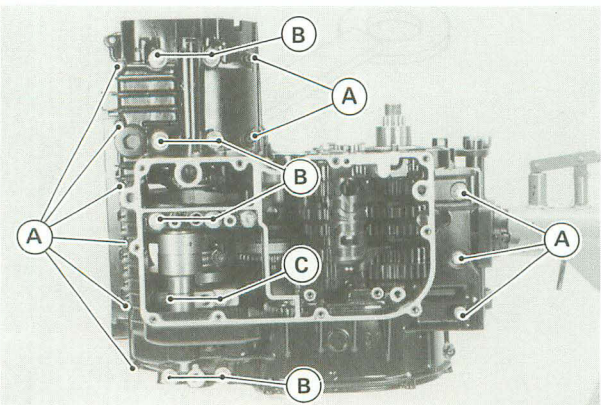

A. 6 mm Bolts
 B. 8 mm Bolts
 C. Remove is not necessary for crankcase split.

- Pry the points indicated in the figure to split the crankcase halves apart, and remove the lower crankcase half.

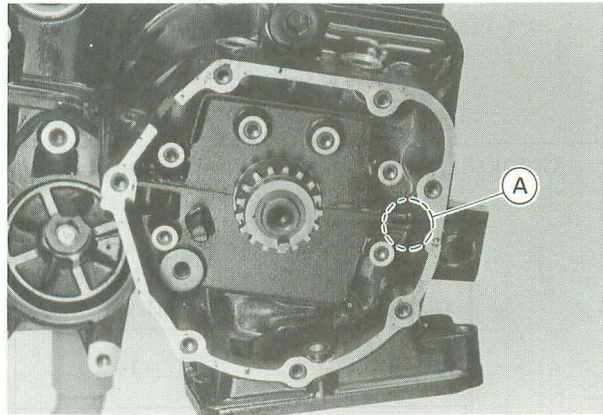

A. Pry Point

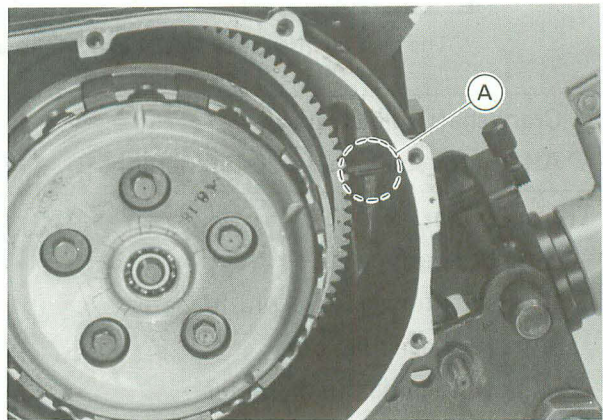

A. Pry Point

Crankcase Assembly

NOTE

○ The upper crankcase half, the lower crankcase half, and the crankshaft main bearing cap are machined at the factory in the assembled state, so the crankcase halves and the main bearing cap must be replaced together as a set.

- Assembly is the reverse of splitting. Note the following.

- Before fitting the lower case on the upper case, check the following.

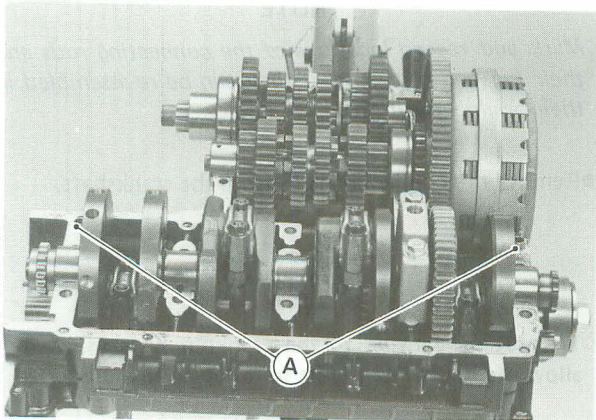

A. Knock Pins

- Shift drum is in the neutral position (neutral positioning lever fits into the detent on the shift drum bearing holder).
- #1 and 4 pistons are at TDC.

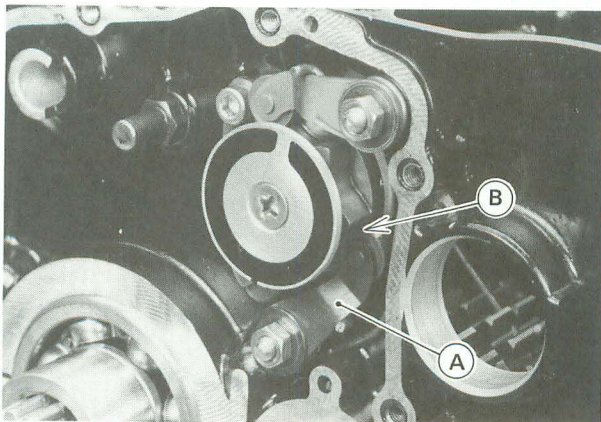

A. Neutral Positioning Lever B. Neutral Detent

- With a high flash-point solvent, clean off the mating surfaces of the crankcases halves and wipe dry.
- Apply a liquid gasket to the mating surface of the lower crankcase half.

CAUTION

- Do not apply a liquid gasket around the crankshaft main bearing inserts.

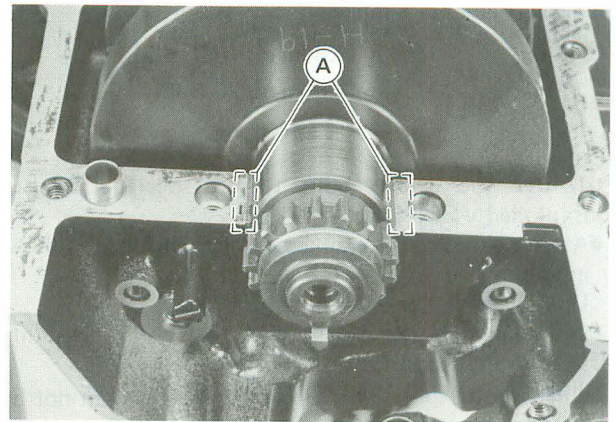

A. Do not apply a liquid gasket here.

- Hold the balancer so that the mark on the balancer weight aligns with the center of the oil passage hole.

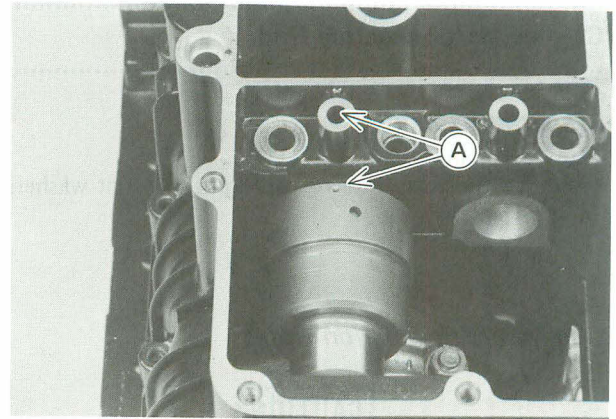

A. Align mark with hole center.

- Tighten the lower crankcase half bolts using the following 3 steps.
- Lightly tighten all lower crankcase half bolts to a snug fit. The three 8 mm bolts (sequence numbered 1 through 3) have a flat washer.
- Torque the 8 mm bolts. The sequence numbers on the lower crankcase half.

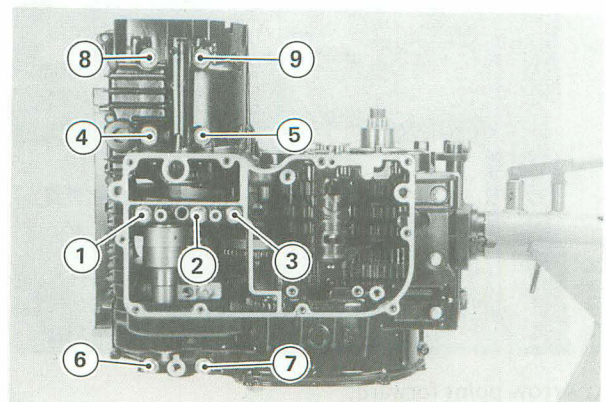

8-8 CRANKSHAFT/TRANSMISSION

Torque Value for 8 mm Bolts

- First:** 14 N-m (1.4 kg-m, 10.0 ft-lb)
Final: 27 N-m (2.8 kg-m, 20 ft-lb)

- Torque the 6 mm bolts to the specification (see Exploded View).
- After tightening all crankcase bolts, check the following items:
 - Drive shaft and output shafts turn freely.
 - While spinning the output shaft, gears shift smoothly from the 1st to 6th gear, and 6th to 1st.
 - When the output shaft stays still, the gear can not be shift to 2nd gear or other higher gear positions.

Crankshaft/Connecting Rods

Crankshaft Removal

- Split the crankcase.
- Remove the main bearing cap bolts with flat washers, and take off the cap.

Crankshaft Installation Notes

CAUTION

- If the crankshaft or bearing inserts are replaced with new ones, check clearance with plastigage before assembling engine to be sure the correct bearing inserts are installed.
- Install the crankshaft main bearing cap with the arrow on it pointing forward. Tighten bolts to the specified torque (see Exploded View).

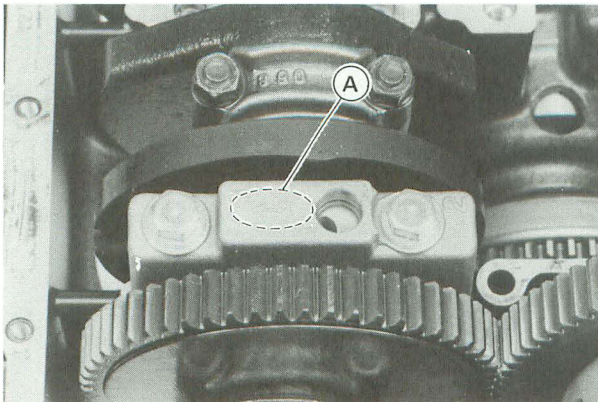

A. Arrow point forward.

Connecting Rod Removal

- Remove the crankshaft.

NOTE

- Mark and record locations of the connecting rods and their big end caps so that they can be re-assembled in their original positions.
- Remove the connecting rods from the crankshaft.

CAUTION

- To prevent damage to the crankpin surfaces, do not allow the big end cap bolts to bump against them.

Connecting Rod Installation

CAUTION

- To minimize vibration, a pair of connecting rod (left two rods or right two) should have the same weight mark.

Weight Mark Location

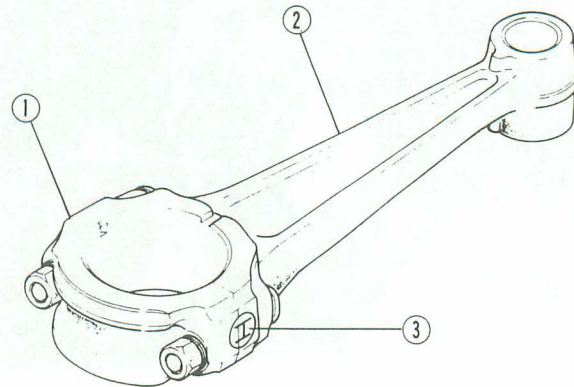

1. Big end cap
2. Connecting rod
3. Weight mark, alphabet

- If the connecting rods or bearing inserts are replaced with new ones check clearance with plastigage before assembling engine to be sure the correct bearing inserts are installed.
- Apply molybdenum disulfide grease to the upper inner surface of the connecting rod big end.
- Apply engine oil to the inner surface of upper or lower bearing inserts.

Connecting Rod and Bearing Insert

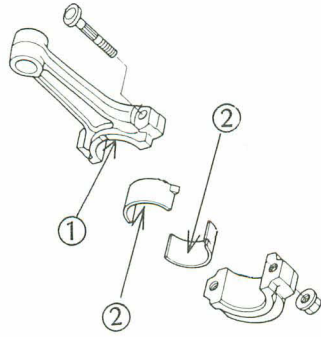

1. Apply molybdenum disulfide grease.
2. Apply engine oil.

CAUTION

- The connecting rod bolts are designed to stretch when tightened. Never reuse them. Replace the connecting rod bolts with new ones.
- The connecting bolt, nut, and connecting rod are treated with an anti-rust solution, be sure to clean the bolt, nut, and connecting rod thoroughly with high flash-point solvent.
- Before assembling, measure the length of new connecting rod bolts and learn the valves to find out the stretch of bolt.

WARNING

- Clean the bolts, nuts, and connecting rods in a well-ventilated area, and take care that there is no spark or flame anywhere near the working area, this includes any appliance with a pilot light. Because of the danger of highly flammable liquides, do not use gasoline or low flash-point solvents to clean them.

CAUTION

- Immediately dry the bolts and nuts with compressed air after cleaning.
- Clean and dry the bolts and nuts completely.
- Apply a small amount of engine oil to the threads and seating surface of the connecting rod bolts and nuts.
- Tighten the nuts to the specified torque, according to whether connecting rod and nut are new or old.

Connecting Rod Ass'y	Nut	Torque N-m (kg-m, ft-lb)
New	In Ass'y or Old	18 (1.8, 13.0)
	New	20 (2.0, 14.5)
Old (Bolt must be new)	Old	24 (2.4, 17.4)
	New	25 (2.6, 18.8)

NOTE

○Since the friction force of the seating surface and thread portion of new nuts is different from that of old one, the nut tightening torque should be changed as specified in the above table.

- Tighten the nuts 120° more.

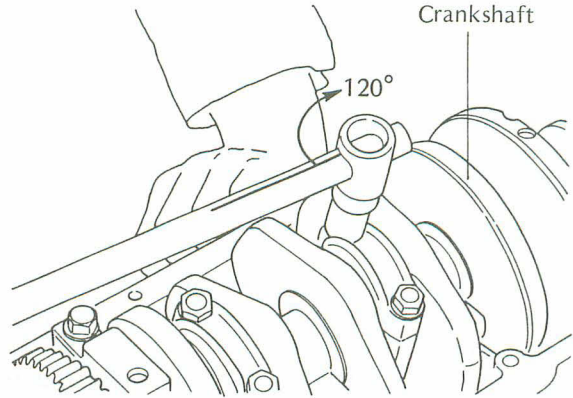

CAUTION

- Be careful not to overtighten the nuts.
- Check the length of connecting rod bolts.
- ★If the stretch is more than service limit, the bolt has stretched too much. Replace the bolt and nut with new ones. An overelongated bolt may break in use.

$$\left(\text{Bolt Length After assembled} \right) - \left(\text{Bolt Length Before assembling} \right) = \text{Stretch}$$

Service Limit

New connecting rod	0.31 mm
Old connecting rod	0.37 mm

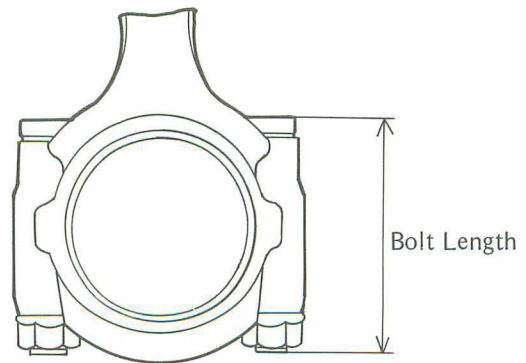

Connecting Rod Big End Bearing Insert/Crankpin Wear

- Measure the bearing insert/crankpin clearance with a plastigage.

8-10 CRANKSHAFT/TRANSMISSION

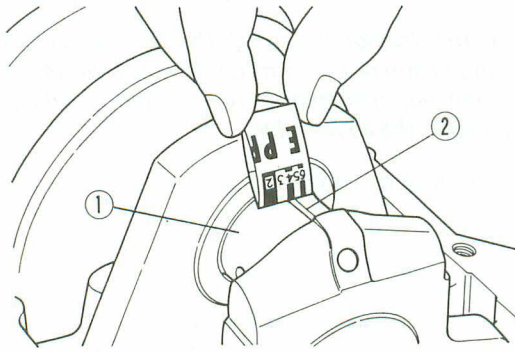

1. Crankpin 2. Plastigage

NOTE

- Tighten the big end cap nuts to the specified torque (see Exploded View).
- Do not move the connecting rod and crankshaft during clearance measurement.

Connecting Rod Big End

Bearing Insert/Crankpin Clearance

Standard:	0.036 – 0.066 mm
Service Limit:	0.10 mm

- ★ If clearance is within the standard, no bearing replacement is required.
- ★ If clearance is between 0.066 mm and the service limit (0.10 mm), replace the bearing inserts with inserts painted blue. Check insert/crankpin clearance with the plastigage. The clearance may exceed the standard slightly, but it must not be less than the minimum in order to avoid bearing seizure.
- ★ If clearance exceeds the service limit, measure the diameter of the crankpins.

Crankpin Diameter

Standard:	34.984 – 35.000 mm
Service Limit:	34.97 mm

- ★ If any crankpin has worn past the service limit, replace the crankshaft with a new one.
- ★ If the measured crankpin diameters are not less than the service limit, but do not coincide with the original diameter markings on the crankshaft, make new marks on it.

Crankpin Diameter Marks

None:	34.984 – 34.992 mm
○ :	34.993 – 35.000 mm

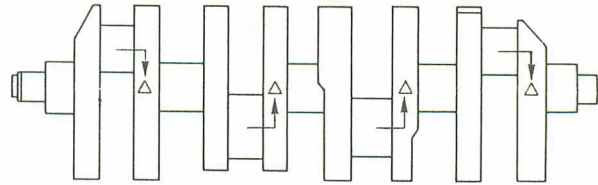

Δ Crankpin Diameter Marks, “○” mark or no mark

- Measure the connecting rod big end inside diameter, and mark each connecting rod big end in accordance with the inside diameter.

NOTE

- Tighten the cap nuts to the specified torque (see Exploded View).
- The mark already on the big end should almost coincide with the measurement.

Connecting Rod Big End Inside Diameter Marks

None:	38.000 – 38.008 mm
○ :	38.009 – 38.016 mm

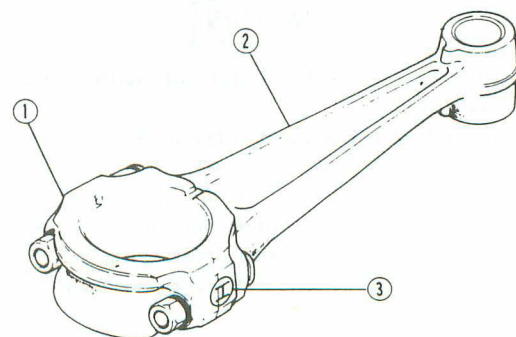

1. Big End Cap 3. Diameter Mark,
2. Connecting Rod “○” mark or no mark

- Select the proper bearing insert in accordance with the combination of the connecting rod and crankshaft coding.

Big End Bearing Insert Selection

Con-rod Big End Bore Diameter Marking	Crankpin Diameter Mark	Bearing Insert	
		Size Color	Part Number
None	None	Blue	92028-1407
○	○		
○	None	White	92028-1547
None	○	Black	92028-1408

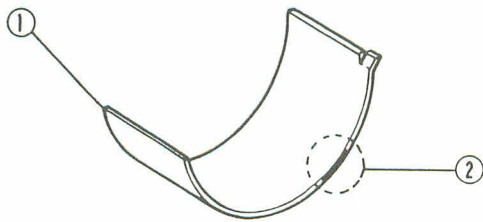

1. Bearing Insert 2. Color Size Mark

● Install the new inserts in the connecting rod and check insert/crankpin clearance with the plastigage.

Crankshaft Main Bearing Insert/Journal Wear

● Measure the bearing insert/crankshaft main journal clearance with a plastigage.

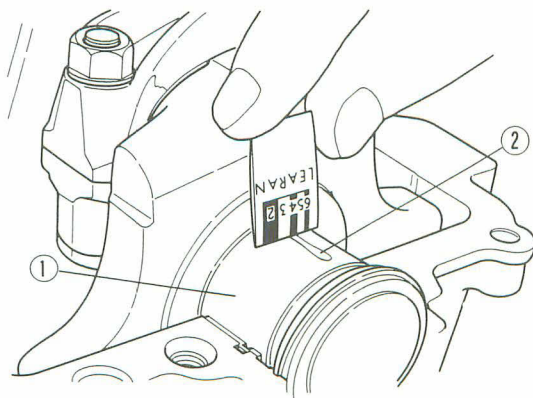

1. Crankshaft Main Journal 2. Plastigage

NOTE

- Tighten the crankcase bolts to the specified torque (see Exploded View).
- Do not turn the crankshaft during clearance measurement.

Crankshaft Main Bearing Insert/Journal Clearance

Standard: 0.020 – 0.044 mm
Service Limit: 0.08mm

- ★ If clearance is within the standard, no bearing replacement is required.
- ★ If clearance is between 0.044 mm and the service limit (0.08 mm), replace the bearing inserts with inserts painted white. Check insert/journal clearance with the plastigage. The clearance may exceed the standard slightly, but it must not be less than the minimum in order to avoid bearing seizure.
- ★ If clearance exceeds the service limit, measure the diameter of the crankshaft main journal.

Crankshaft Main Journal Diameter

Standard: 35.984 – 36.000 mm
Service Limit: 35.96 mm

- ★ If any journal has worn past the service limit, replace the crankshaft with a new one.
- ★ If the measured journal diameters are not less than the service limit, but do not coincide with the original diameter markings on the crankshaft, make new marks on it.

Crankshaft Main Journal Diameter Marks

None: 35.984 – 35.992 mm
1 : 35.993 – 36.000 mm

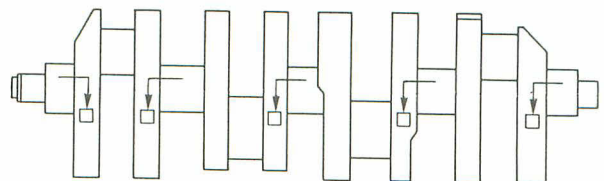

□ Crankshaft Main Journal Diameter Marks, "1" mark or no mark

8-12 CRANKSHAFT/TRANSMISSION

- Measure the main bearing bore diameter, and mark the upper crankcase half in accordance with the bore diameter.

NOTE

- Tighten the crankcase bolts to the specified torque (see Exploded View).
- The mark already on the upper crankcase half should almost coincide with the measurement.

Crankcase Main Bearing Bore Diameter Marks

○ :	39.000 – 39.008 mm
None :	39.009 – 39.016 mm

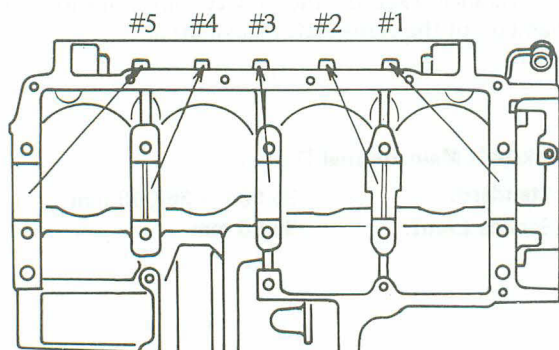

- Select the proper bearing insert in accordance with the combination of the crankcase and crankshaft coding.

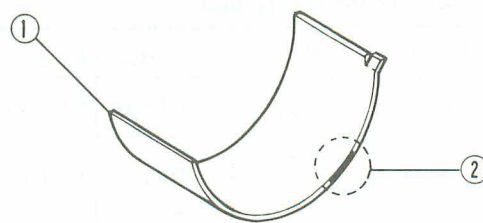

1. Bearing Insert
2. Size Color Mark

- Install the new inserts in the crankcase halves and check insert/journal clearance with plastigage.

Crankshaft Runout

- Measure the crankshaft runout.
- ★ If the measurement exceeds the service limit, replace the crankshaft.

Crankshaft Runout

Service Limit: 0.05 mm TIR

Crankshaft Runout

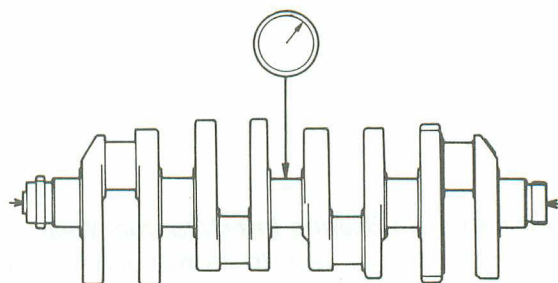

Bearing Insert Selection

Crankcase Main Bearing Bore Diameter Mark	Crankshaft Main Journal Diameter Mark	Bearing Insert*		
		Size Color	Part Number	Journal Nos.
○	1	Brown	92028-1102	2, 4
			92028-1274	1, 3, 5
None	None	Blue	92028-1100	2, 4
			92028-1272	1, 3, 5
○	None	Black	92028-1101	2, 4
			92028-1273	1, 3, 5

*The bearing inserts for Nos. 2 and 4 journals have oil groove.

Crankshaft Side Clearance

- Insert a thickness gauge between the crankcase main bearing cap and the crank web at the No. 2 journal to determine clearance.
- ★ If the clearance exceeds the service limit, replace the crankcase halves and main bearing cap as a set.

NOTE

○ The upper crankcase half, lower crankcase half, and main bearing cap are machined at the factory in the assembled state, so they must be replaced as a set.

Crankshaft Side Clearance

Standard:	0.05 – 0.20 mm
Service Limit:	0.40 mm

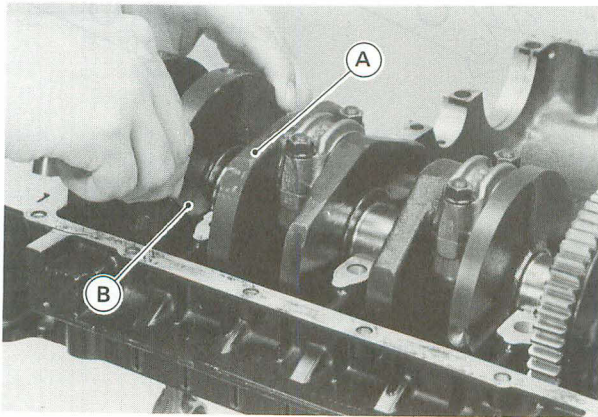

A. Crankshaft B. Thickness Gauge

Balancer Installation Notes

- When coupling the balancer weight and the gear, observe the following.
- Check that the damper rubbers are in place.
- Fit the balancer weight into the gear so that the weight is opposite the mark on the gear.

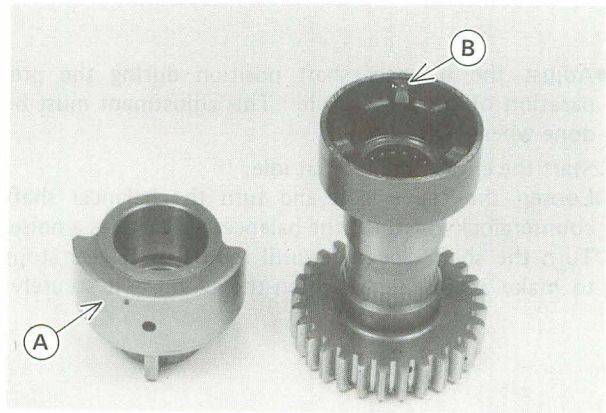

A. Weight Portion B. Mark

- Fit the copper washers on both sides of the weight and gear assembly. The projected side faces toward the assembly.

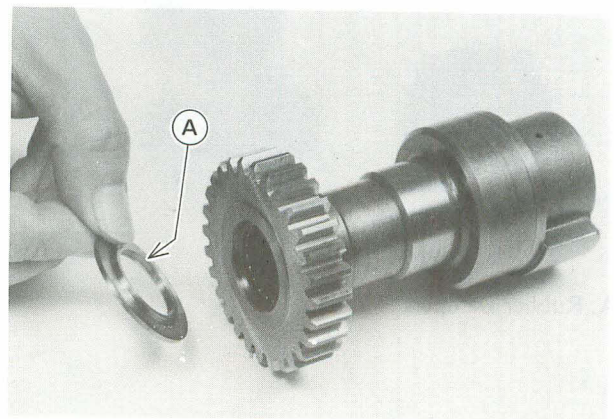

A. Projected Side

Balancer

Balancer Removal

- Split the crankcase.
- Unscrew the balancer shaft clamp bolts, and pull off the clamp lever.
- Unscrew the bolt holding the balancer shaft guide pin plate, and take off the plate and guide pin.
- Pull the balancer shaft with the oil seal toward the right out of the crankcase. At the same time, the balancer weight and gear assembly comes off.

- Turn the balancer shaft until the line mark on the end of the shaft points to the front. And then, install the clamp lever. Tighten the bolt at the rear of the lever first then tighten the clamp bolt at the front of the lever temporarily.

8-14 CRANKSHAFT/TRANSMISSION

Balancer Shaft Installation

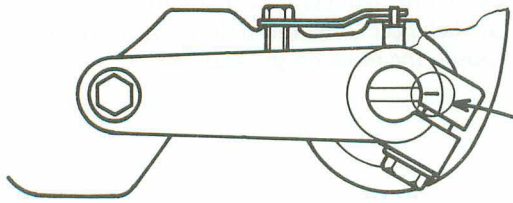

- Adjust the balancer shaft position during the preparation of the motorcycle. This adjustment must be done when engine is cold.
- Start the engine and let it at idle.
- Loosen the clamp bolt and turn the balancer shaft counterclockwise until the balancer gear makes a noise.
- Turn the shaft clockwise until the balancer gear stops to make a noise, and tighten the clamp bolt securely.

Damper Inspection

- Remove the balancer and disassemble the weight and gear assembly.
- Visually inspect the rubber dampers.
- ★ If they appear damaged or deteriorated, replace them.

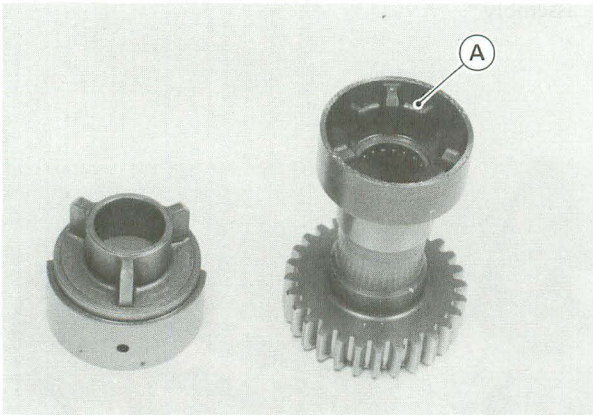

A. Rubber Dampers

Needle Bearing Wear

- Visually check the needle bearings.
- The rollers in a needle bearing normally wear very little, and wear is difficult to measure. Instead of measuring, inspect the bearing for abrasion, color change, or other damage.
- ★ If there is any doubt as to the condition of a needle bearing, replace it.

Alternator Shaft/Starter Motor Clutch

Alternator Chain and Tensioner Removal

- Remove the right engine cover.
- Lock the alternator shaft chain tensioner.
- Push the tensioner guide and the rod stop lever so that the stop lever keeps the rod from returning.

Free Positioned

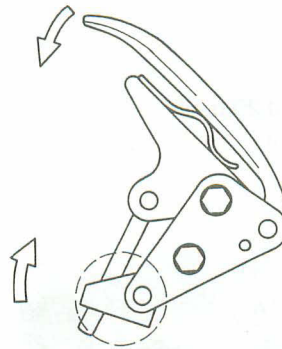

Lock Positioned

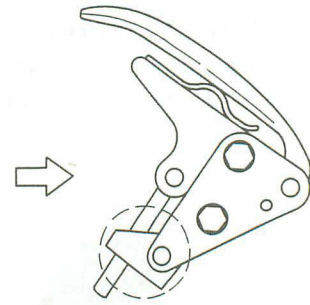

- Remove the chain guide.

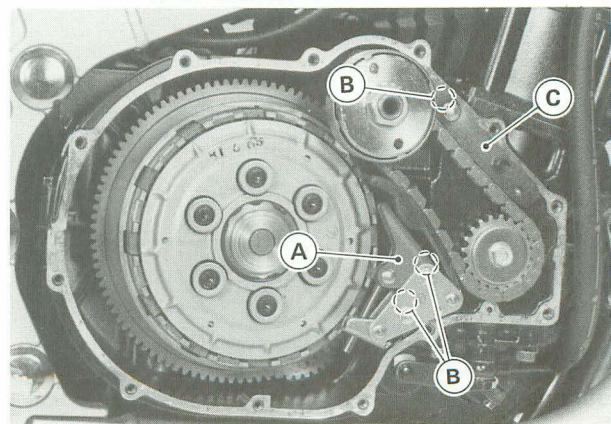

A. Alternator Chain Tensioner
B. Bolts
C. Chain Guide

- Remove the alternator chain tensioner.
- Hold the alternator coupling with the coupling holder (special tool), and remove the coupling nut and sprocket bolt.

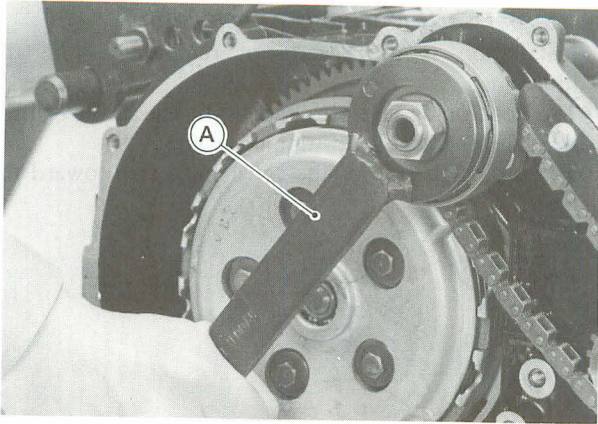

A. Coupling Holder: 57001-1189

- Pull the chain, sprocket, and coupling as a set.

Alternator Chain and Tensioner Installation

- Installation is the reverse of removal. Note the following.
- Tighten the following bolt and nut to the specified torque (see Exploded View).
 Alternator Coupling Nut
 Alternator Sprocket Bolt
- Lock the chain tensioner and install it with the mounting bolts. The tensioner should be free from the locked position after installing it.

Alternator Shaft and Starter Clutch Removal

- Split the crankcase.
- Remove the alternator chain.
- Remove the coupling bolt at the left end of the shaft, and then remove the coupling with the rubber dampers.
- Holding the starter motor clutch, pull the alternator shaft off the crankcase.

Alternator Shaft and Starter Clutch Installation

- Installation is the reverse of removal. Note the following.
- If the starter motor idle gear is removed, install it so that the small diameter gear side faces to the left.

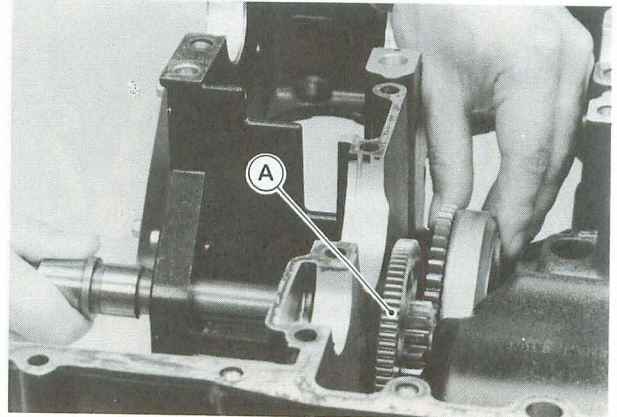

A. Idle Gear

- Tighten the alternator coupling bolt to the specified torque (see Exploded View).

Alternator Shaft Chain Wear

- Hold the alternator shaft chain so that it may be pulled tight.
- Measure the length of 20 links (21 pins) with a vernier caliper.
- ★ If the 20-link length of the alternator shaft chain is greater than the service limit, replace it.

Alternator Shaft Chain 20-link length

Standard:	158.8 – 159.2 mm
Service Limit:	161.5 mm

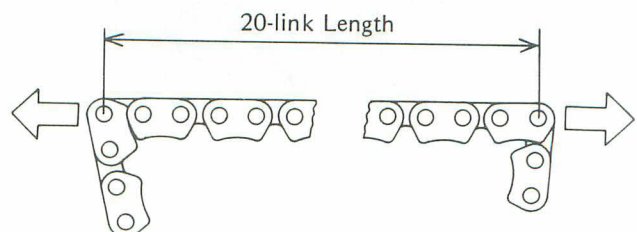

8-16 CRANKSHAFT/TRANSMISSION

Starter Motor Clutch Inspection

- Remove the starter motor.
- Turn the starter motor idle gear by hand. When viewed from the left side of the engine, the idle gear should turn counterclockwise freely, but should not turn clockwise.

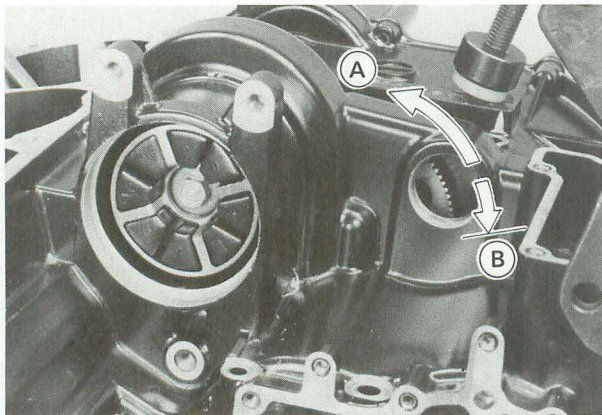

A. Turn freely. B. Locked

Transmission

External Shift Mechanism Removal

- Drain the engine oil.
- Remove the engine (see Engine Removal/Installation chapter).
- Remove the following.
 - Engine Sprocket
 - Water Pump
 - External Mechanism Cover
- Remove the shift shaft, while moving the shift mechanism arm backward.

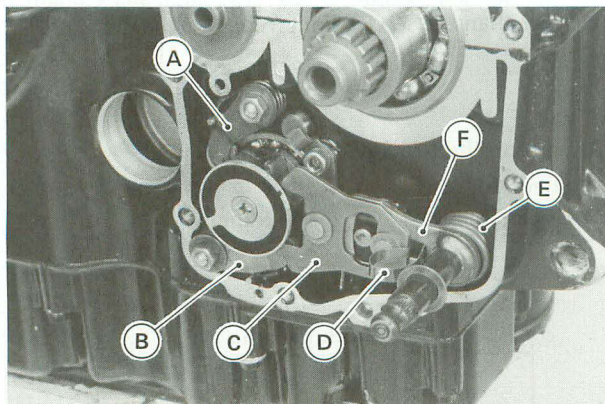

A. Neutral Positioning Lever D. Arm Spring
 B. Gear Positioning Lever E. Return Spring
 C. Shift Mechanism Arm F. Shift Shaft

- Unscrew the nuts and remove the positioning levers.

External Shift Mechanism Installation

- Installation is the reverse of removal. Note the following.
- The positioning levers are identical. The spring painted white is for the gear positioning lever.
- The projected side of the collar must face toward the lever.

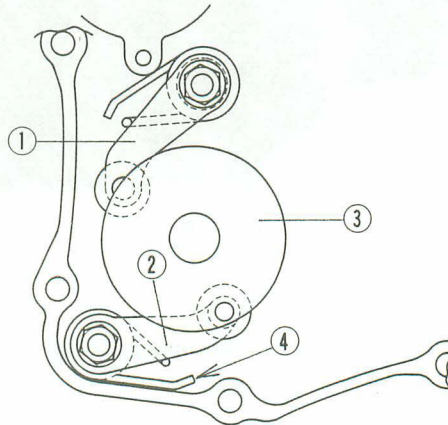

1. Neutral Positioning Lever 3. Change Drum
 2. Gear Positioning Lever 4. White Spring

External Shift Mechanism Inspection

- Examine the shift shaft for any damage.

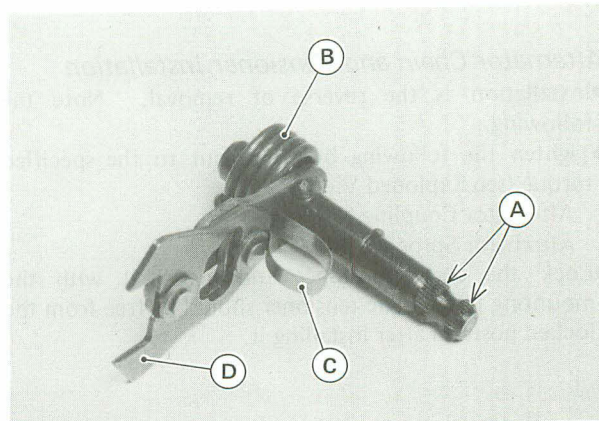

A. Splines C. Arm Spring
 B. Return Spring D. Arm

- ★ If the shaft is bent, straighten or replace it. If the splines are damaged, replace the shaft.
- ★ If the springs are damaged in any way, replace them.
- ★ If the shift mechanism arm is damaged in any way, replace the arm.
- Check the return spring pin is not loose.
- ★ If it is loose, unscrew it, apply a non-permanent locking agent to the threads, and tighten it to the specified torque (see Exploded View).
- Check the positioning levers and their springs for breaks or distortion.
- ★ If the levers or springs are damaged in any way, replace them.

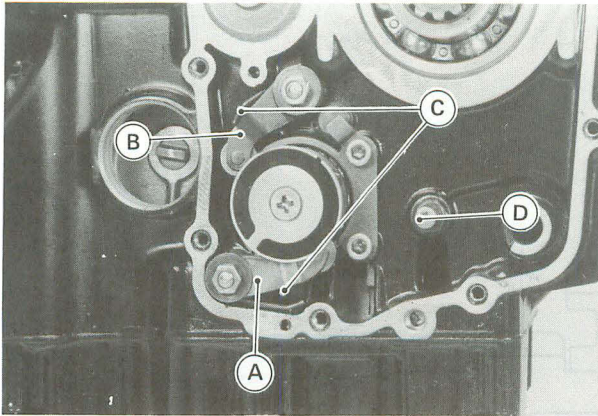

A. Neutral Positioning Lever C. Springs
B. Gear Positioning Lever D. Return Spring Pin

- Visually inspect the shift drum pins, pin holder, and pin plate.
- ★If they are badly worn or if they show any damage, replace them.

Transmission Shaft Removal

NOTE

○If the drive shaft assembly is to be disassembled, remove the clutch.

- Split the crankcase.
- Take out the drive and output shaft assemblies.

Transmission Shaft Installation

- Installation is the reverse of removal. Note the following.
- Check to see that the set rings and set pins are in place in the transmission bearing housings, and blow the oil passages in the bearing housings clean with compressed air.

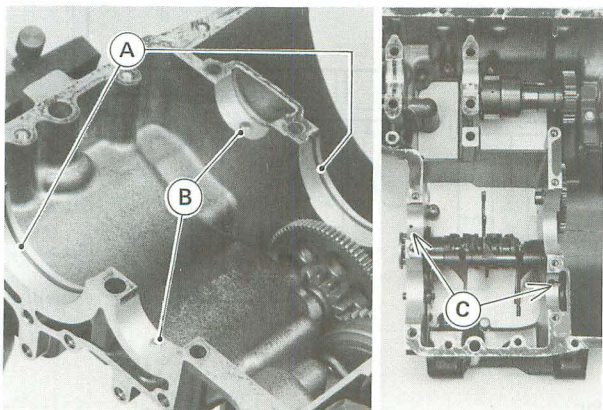

A. Set Rings C. Oil Passage Holes
B. Set Pins

- Install the drive and output shaft assemblies in the upper crankcase half.

○The bearing set pins and rings must match properly with the holes or grooves in the bearing outer races. When they are properly matched, there is no clearance between the crankcase and the bearing outer races.

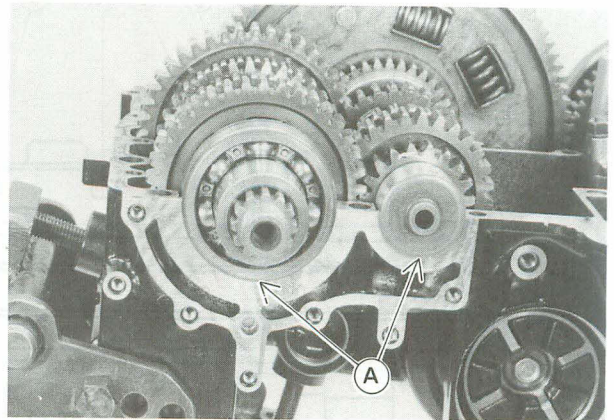

A. No Clearance (both left and right sides)

Transmission Disassembly

- Remove the transmission shafts.
- Using the circlip pliers (special tool: 57001-144) to remove the circlips, disassemble the transmission shafts.
- The 5th gear on the output shaft has three steel balls assembled into it for the positive neutral finder mechanism. Remove the 5th gear as the following.
- Set the output shaft in a vertical position holding the 3rd gear.
- Spin the 5th gear quickly and pull it off upward.

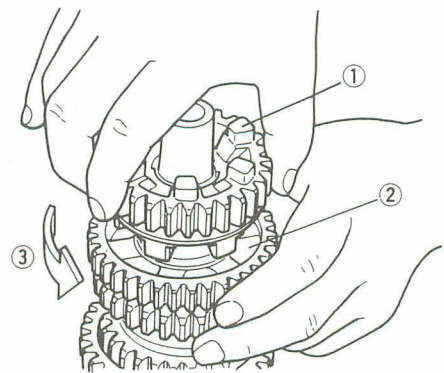

1. 5th Gear 3. Spin quickly.
2. 3rd Gear

Transmission Assembly

- Assembly is the reverse of disassembly. Note the following.
- Replace any circlips that were removed with new ones.
- Install the circlips so that the opening is aligned with a spline groove.
- Install the toothed washers so that the teeth are not aligned with the circlip opening.

8-18 CRANKSHAFT/TRANSMISSION

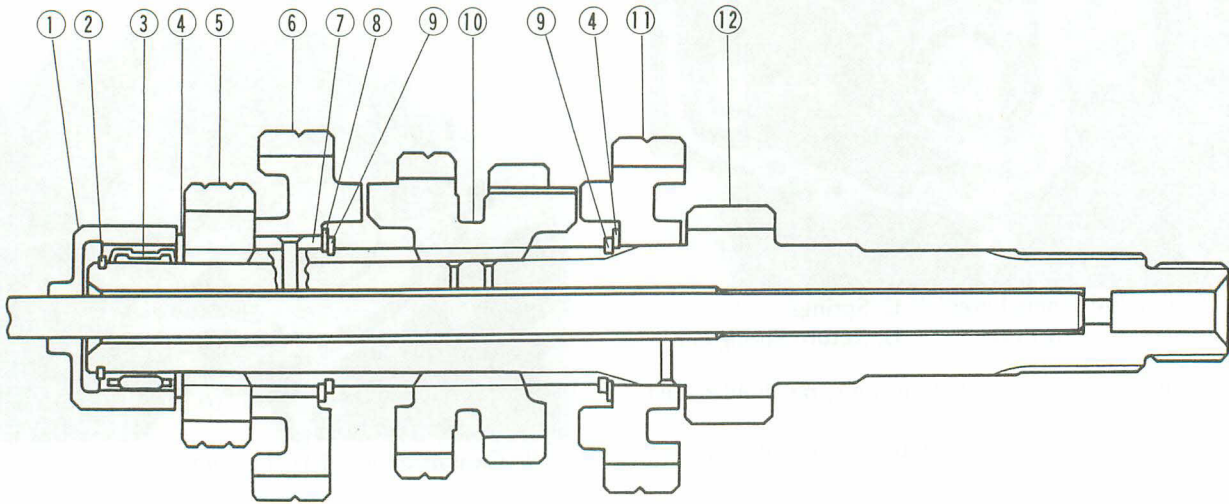

1. Bearing Outer Race
2. Circlip
3. Needle Bearing
4. Thrust Washer
5. 2nd Gear

6. Top (6th) Gear
7. Bushing
8. Toothed Washer
9. Circlip
10. 3rd/4th Gear

11. 5th Gear
12. 1st Gear (Drive Shaft)

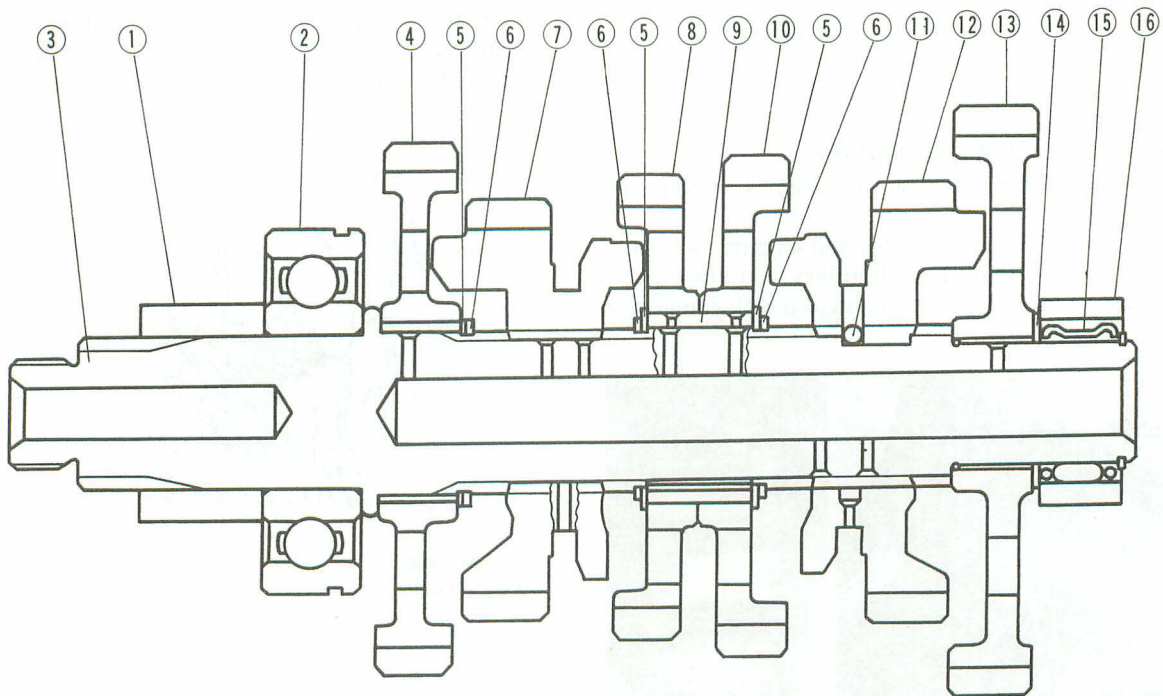

1. Collar
2. Ball Bearing
3. Output Shaft
4. 2nd Gear
5. Toothed Washer
6. Circlip

7. Top (6th) Gear
8. 4th Gear
9. Bushing
10. 3rd Gear
11. Steel Ball
12. 5th Gear

13. 1st Gear
14. Thrust Washer
15. Needle Bearing
16. Bearing Outer Race

CAUTION

Do not apply grease to the steel balls to hold them in place. This will cause the positive neutral finder mechanism to malfunction.

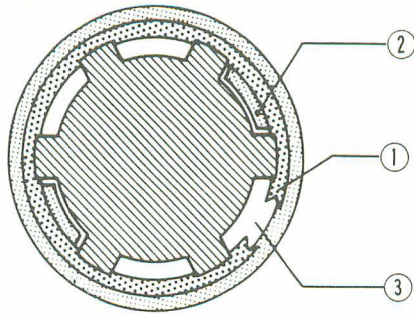

- 1. Circlip
- 2. Toothed Washer
- 3. Groove

Install the gear bushings on the shafts with their oil holes aligned with the shaft oil holes.

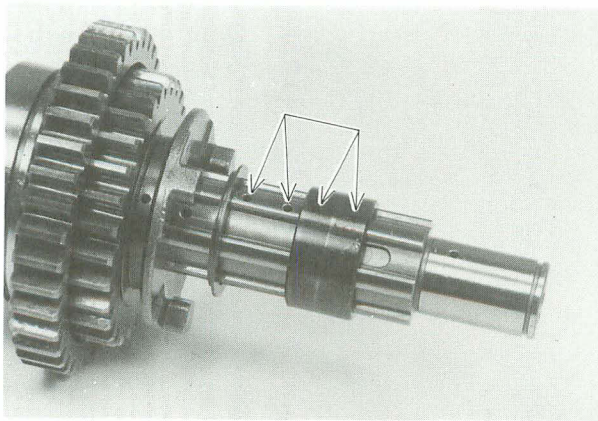

Fit the steel balls into the 5th gear holes that are smaller than the other holes as seen from the outside of the gear, and then install the gear on the shaft so that the steel balls align with the recesses in the shaft.

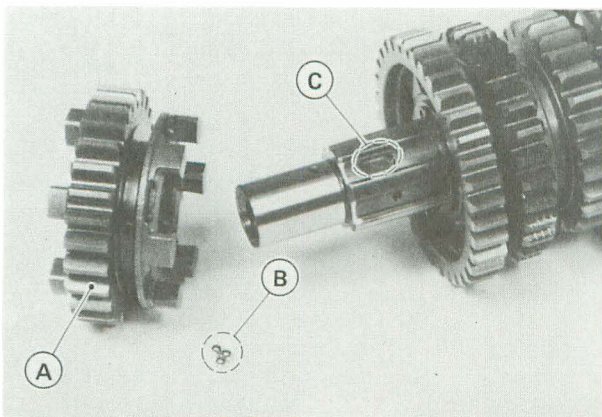

- A. 5th Gear
- B. Steel Balls
- C. Recess

Shift Drum and Fork Removal

- Remove the engine (see Engine Removal/Installation chapter).
- Remove the following.
 - External Shift Mechanism
 - Oil Pan
 - Oil Pump and Bracket
- Unscrew the Allen bolts holding the shift drum ball bearing holder.

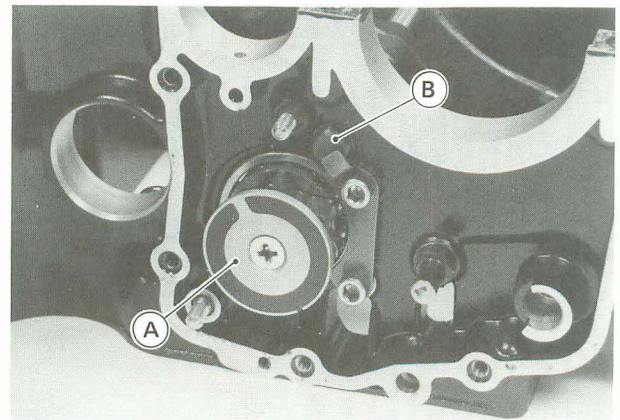

- A. Shift Drum
- B. Shift Rod

- Pull out the shift rod, and take off the shift forks.
- Pull out the shift drum.

Shift Drum and Fork Installation

- Installation is the reverse of removal. Note the following.
- Apply a non-permanent locking agent to the Allen bolts of the shift drum holding plate.
- The shift forks can be identified by their shape. Install them as following.

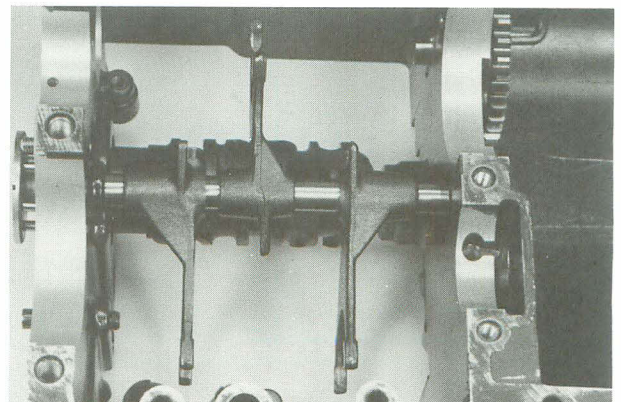

Wheels/Tires

Table of Contents

Exploded View	9-2
Specifications	9-3
Special Tools	9-4
Wheels (Rims)	9-5
Front Wheel Removal	9-5
Front Wheel Installation	9-5
Rear Wheel Removal	9-6
Rear Wheel Installation	9-6
Wheel Inspection	9-6
Balance Weight Installation	9-7
Balance Weight Removal	9-7
Tires	9-8
Tire Air Pressure Inspection	9-8
Tire Inspection	9-8
Hub Bearings	9-9
Removal	9-9
Installation	9-9
Lubrication	9-9
Speedometer Gear Housing	9-9
Disassembly and Assembly	9-9
Lubrication	9-10

9-2 WHEELS/TIRES

Exploded View

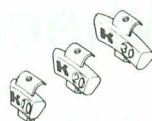
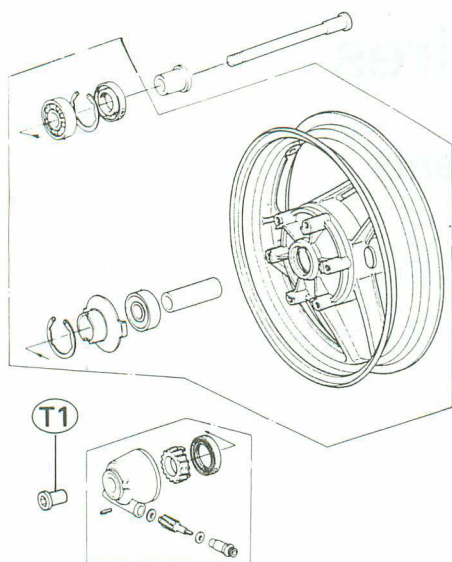

ZX1000-B1

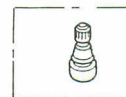
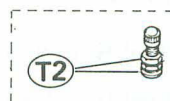

T1: 88 N-m (9.0 kg-m, 65 ft-lb)
T2: 1.5 N-m (0.15 kg-m, 13 in-lb)
T3: 108 N-m (11.0 kg-m, 80 ft-lb)

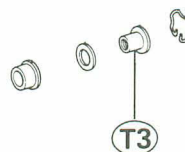
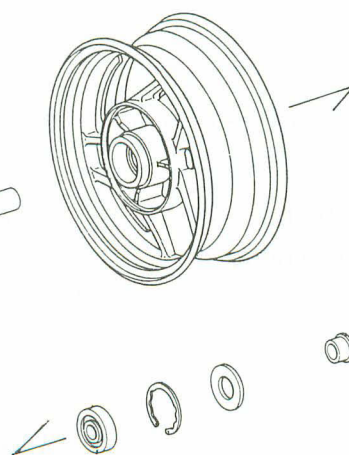
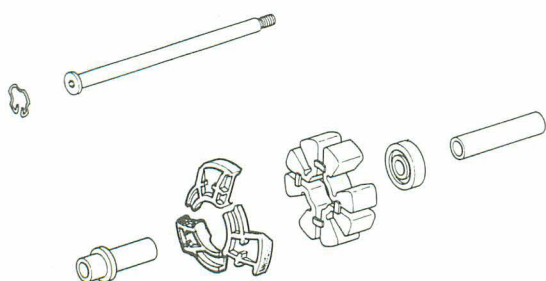
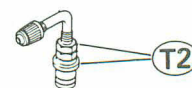
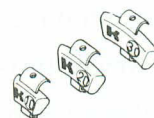

Specifications

Item		Standard	Service Limit		
Wheels:					
Tire tread depth.	Front	3.9 mm	1 mm		
	Rear	6.9 mm	2 mm (Under 130 km/h) (Under 80 mph) 3 mm (Over 130 km/h) (Over 80 mph)		
Standard tire	Front	120/70 VR17-V280 TUBELESS DUNLOP K455FG BRIDGESTONE CYROX-03 120/70 VB17-V280 TUBELESS METZELER ME33 LASER 120/70 ZR17 TUBELESS PIRELLI MP7 SPORT MICHELIN A59X			
	Rear	160/60 VR18-V280 TUBELESS DUNLOP K455A BRIDGESTONE CYROX-04 160/60 VB18-V280 TUBELESS METZELER ME1 160/60 ZR18 TUBELESS PIRELLI MP7 SPORT MICHELIN M59X			
Tire air pressure			Load	Air Pressure (when cold)	
				Under 210 km/h (Under 130 mph)	Over 210 km/h (Over 130 mph)
	US and Canadian Model	Front	Up to 180 kg (397 lb)	250 kPa (2.5 kg/cm ² , 36 psi)	
		Rear		290 kPa (2.9 kg/cm ² , 41 psi)	
	Other than US and Canadian Model	Front	Up to 975. kg (215 lb)– 975. kg (215 lb)– 181 kg (399 lb)	250 kPa (2.5 kg/cm ² , 36 psi)	
		Rear		250 kPa (2.5 kg/cm ² , 36 psi)	290 kPa (2.9 kg/cm ² , 41 psi)
290 kPa (2.9 kg/cm ² , 41 psi)					
Rim runout: Axial		---	0.5 mm		
Radial		---	0.8 mm		
Axle runout/100 mm:		Under 0.05 mm	0.2 mm (0.7 mm: RL)		

9-4 WHEELS/TIRES

.....
Special Tools
.....

Circlip Pliers: 57001-143

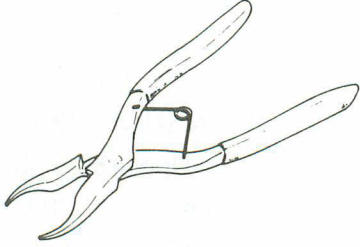

Rim Protector: 57001-1063

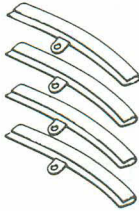

Bead Breaker: 57001-1072

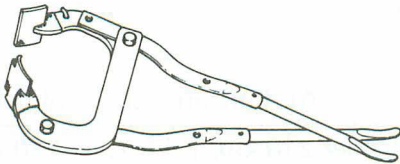

Tire Iron: 57001-1073

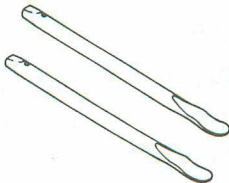

Bearing Driver Set: 57001-1129

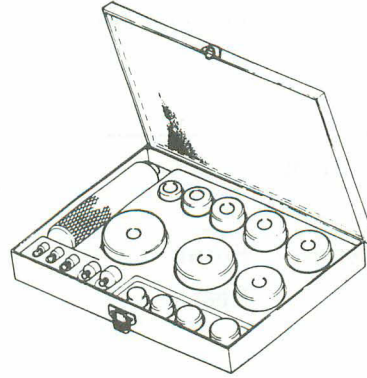

Bearing Remover Set: 57001-1264

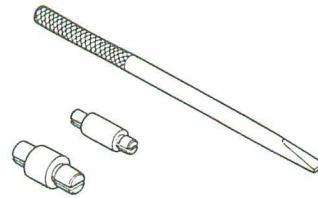

Bearing Remover Head: 57001-1293

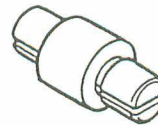

NOTE

○The tire irons (P/N 57001-1073) are included in the bead breaker (P/N 57001-1072).

Wheels (Rims)

Front Wheel Removal

- Remove the following.
 - Lower Fairing
 - Speedometer Cable Lower End
 - Brake Caliper Mounting Bolts

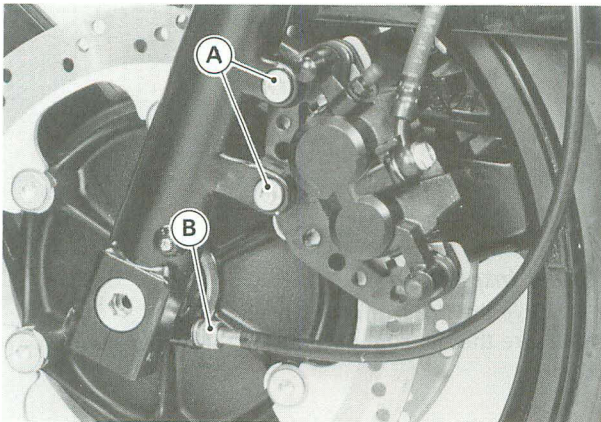

A. Caliper Mounting Bolts B. Speedometer Cable

Right Side Axle Clamp Bolts (Loosen)
Axle (Loosen)

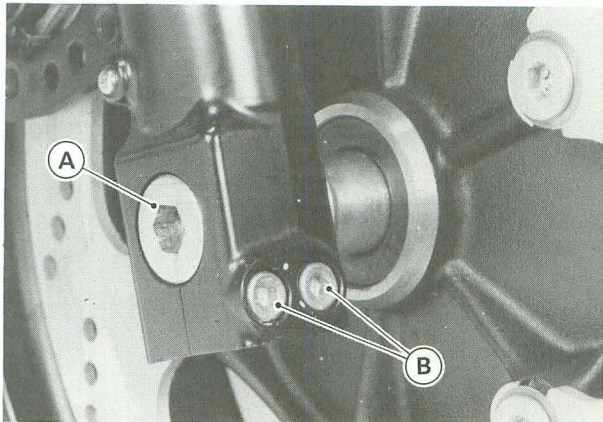

A. Axle B. Axle Clamp Bolts

- Using the jack stand (special tool: 57001-1238), raise the front wheel off the ground.
- Pull out the axle to the right and drop the front wheel out of the forks.

CAUTION

- Do not lay the wheel down on one of the discs. This can damage or warp the disc. Place blocks under the wheel so that the discs do not touch the ground.

Front Wheel Installation

- Installation is the reverse of removal. Note the following.

NOTE

- Put the speedometer gear drive onto the wheel hub notches, then install the housing so that it fits in the drive notches.
- Fit the speedometer gear housing stop to the fork leg stop.

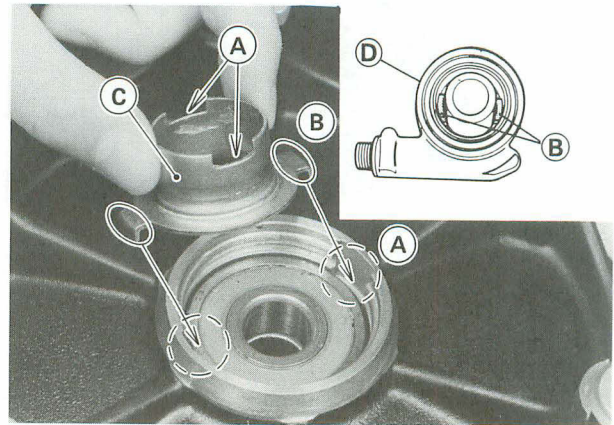

A. Notches C. Drive
B. Projections D. Housing

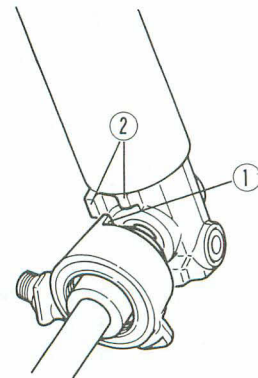

1. Housing Stop 2. Fork Leg Stop

- Fit the collar on the right hand side of the hub.

- Tighten the axle nut to the specified torque (see Exploded View).
- Tighten the axle clamp bolts to the specified torque (see Exploded View).
- Check the front brake.

WARNING

- Do not attempt to drive the motorcycle until fully depressing the brake lever then pump the brake lever until the pads are against the disc. The brakes will not function on the first application of the lever if this is not done.

9-6 WHEELS/TIRES

Rear Wheel Removal

- Loosen the left and right adjuster clamp bolts.

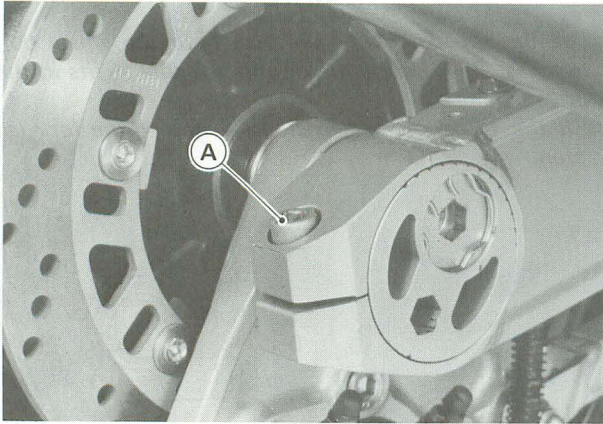

A. Adjuster Clamp Bolt

- Remove the following.
 - Retaining Ring
 - Torque Link Bolt and Nut
 - Axle Nut

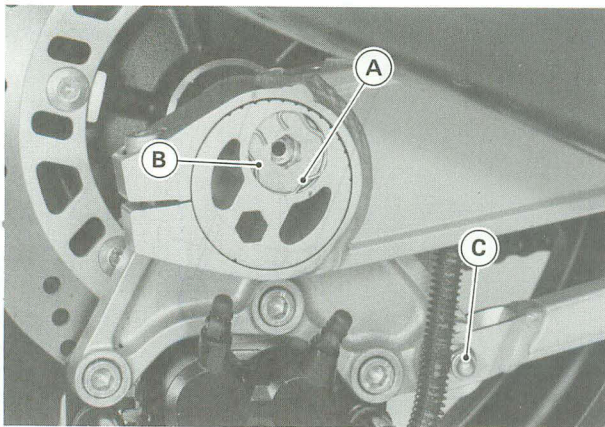

A. Retaining Ring
B. Axle Nut
C. Torque Link Bolt and Nut

- Pull out the axle toward the left.
- Pull the drive chain toward the left, and remove the rear wheel.

CAUTION

- Do not lay the wheel on the ground with the disc facing down. This can damage or warp the disc. Place blocks under the wheel so that the disc does not touch the ground.

Rear Wheel Installation

- Installation is the reverse of removal. Note the following.
- Adjust the drive chain after installation (see Final Drive chapter).
- Tighten the following fasteners to the specified torque (see Exploded View).
 - Axle Nut
 - Adjuster Clamp Bolts (see Suspension chapter)
 - Caliper Mounting Bolts (see Brakes chapter)
 - Torque Link Nut (see Brakes chapter)

Wheel Inspection

- Remove the tire from the wheel.
- Measure the rim runout by using the dial gauge.

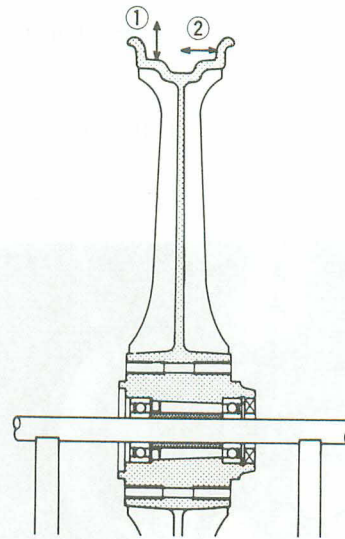

1. Radial Runout 2. Axial Runout

- ★ If rim runout exceeds the service limit, check the wheel bearings.
- ★ If the problem is not due to the bearings, the wheel must be replaced.

Axial Runout

Service Limit: 0.5 mm

Radial Runout

Service Limit: 0.8 mm

WARNING

- Never attempt to repair a damaged wheel. If there is any damage besides wheel bearings, the wheel must be replaced to insure safe operational condition.

Balance Weight Installation

- Check if the weight portion has any play on the blade-and-clip plate.
- ★ If it does, discard it.
- Lubricate the balance weight blade, tire bead, and rim flange with a soap and water solution or rubber lubricant. This helps the balance weight slip onto the rim flange.

CAUTION

- Do not lubricate the tire bead with engine oil or gasoline because they will deteriorate the tire.
- Install the balance weight on the rim.
- Slip the weight on the rim flange by pushing or lightly hammering the weight in the direction shown in the figure.
- Check that the blade and weight seat fully on the rim flange, and that the clip is hooked over the rim ridge and reaches rim flat portion.

WARNING

- If the balance weight has any play on the rim flange, the blade and/or clip have been stretched. Replace the loose balance weight.
- Do not reuse used balance weights.

Balance Weight

Part Number	Weight (grams)
41075-1014	10
41075-1015	20
41075-1016	30

Installing Balance Weight

- (a) Press or lightly hammer the weight in.

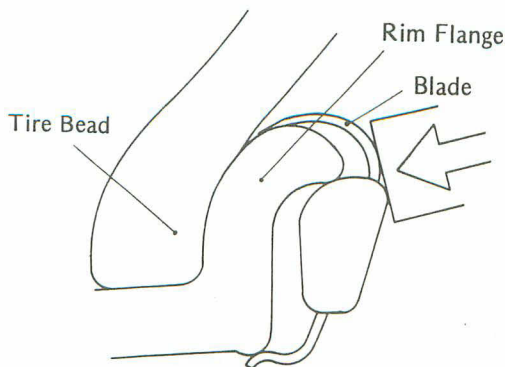

- (b) Installation completed.

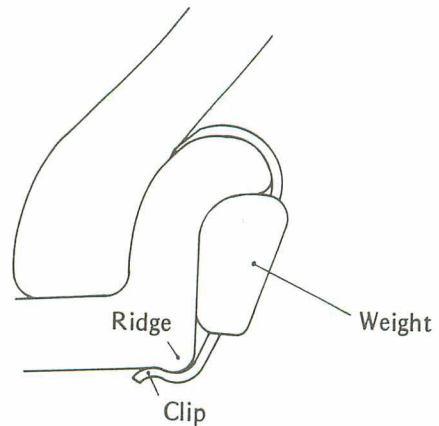

Balance Weight Removal

- (a) When the tire is not on the rim.
 - Push the blade portion toward the outside with a regular tip screw driver, and slip the weight off the rim flange.
 - Discard the used balance weight.

Removing Balance Weight (without tire on rim)

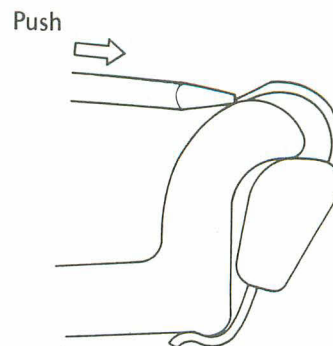

- (b) When the tire is on the rim.
 - Pry the Balance weight off the rim flange using a regular tip screw driver as shown in the figure.
 - Insert a tip of the screw driver between the tire bead and weight blade until the end of the tip reaches the end of the weight blade.
 - Push the driver grip toward the tire so that the balance weight slips off the rim flange.
 - Discard the used balance weight.

9-8 WHEELS/TIRES

Removing Balance Weight (with tire on rim)

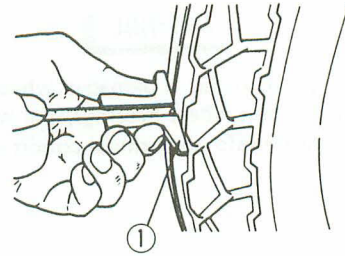
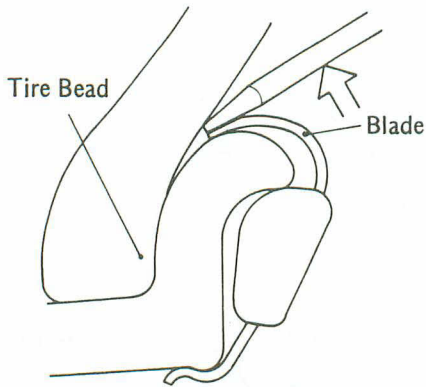

1. Depth Gauge

★If any measurement is less than the service limit, replace the tire.

Tire Tread Depth

Front

Standard	3.9 mm
Service Limit	1 mm

Rear

Standard	6.9 mm
Service Limit	2 mm (Up to 130 km/h) 3 mm (Over 130 km/h)

Tires

Tire Air Pressure Inspection

NOTE

○Measure the tire pressure when the tire are cold (that is, when the motorcycle has not been ridden more than a mile during the past 3 hours).

US and Canadian Model

Front	————	250 kPa (2.5 kg/cm ² , 36 psi)
Rear	Up to 180 kg (397 lb)	290 kPa (2.9 kg/cm ² , 41 psi)

Other than US and Canadian Model

Front	————	250 kPa (2.5 kg/cm ² , 36 psi)
Rear	Up to 97.5 kg (215 lb)	290 kPa (2.9 kg/cm ² , 41 psi)
	97.5 – 181 kg (215 – 399 lb), Over 210 km/h (130 mph)	

Tire Inspection

- Visually inspect the tire for cracks and cuts, replacing the tire in case of bad damage.
- Measure the tread depth at the center of the tread with a depth gauge.

ZX1000-B2 and latest models

Rubber-type air valve and air valve hole modified wheels are used on the front and rear wheels.

Installation

- Remove the air valve and discard it.

CAUTION

- Replace the rubber-type air valve whenever the tire is replaced.
- Do not reuse the air valve.

Air Valve

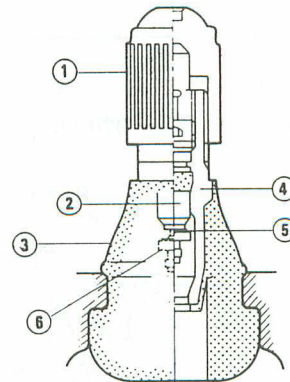

1. Plastic Cap
2. Valve Core
3. Stem Seal

4. Valve Stem
5. Valve Seat
6. Valve Opened

- Install a new valve in the rim.
- Remove the valve cap, lubricate the stem with a soap and water solution, and pull the stem through the rim from the inside out until it snaps into place.

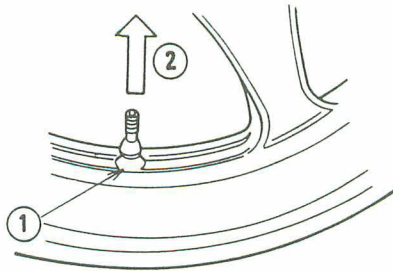

1. Apply soap and water solution.
2. Pull the stem out.

CAUTION

- Do not use engine oil or petroleum distillates to lubricate the stem because they will deteriorate the rubber.

CAUTION

- Do not lay the wheel on the ground with the disc facing down. This can damage or warp the disc. Place blocks under the wheel so that the disc does not touch the ground.

Installation

- Install the bearings by using the bearing driver set (special tools: 57001-1129).

NOTE

- Install the bearings so that the marked or shielded sides face out.

Lubrication

NOTE

- Since the hub bearings are packed with grease and shield, they are not required to be removed for lubrication.

.....
Hub Bearings

Removal

- Use the bearing remover (special tool) to remove the hub bearings.

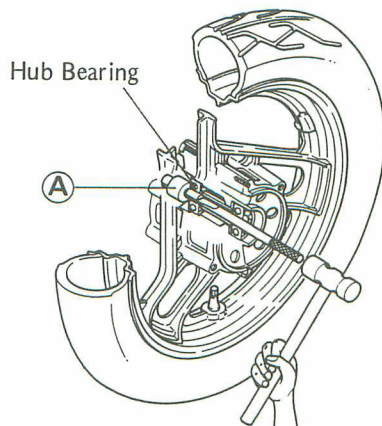

A. Bearing Remover Set: 57001-1264

.....
Speedometer Gear Housing

Disassembly and Assembly

NOTE

- It is recommended that the assembly be replaced rather than attempting to repair the components.

- Install the speedometer gear housing so that it fits in the speedometer gear drive notches (see Front Wheel Installation).

9-10 WHEELS/TIRES

Lubrication

- Clean and grease the speedometer gear housing.

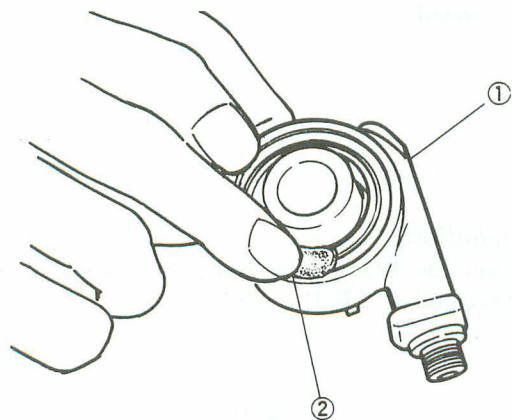

1. Speedometer Gear Housing
2. Grease.

Final Drive

Table of Contents

Exploded View	10-2
Specifications	10-3
Special Tools	10-3
Drive Chain	10-4
Drive Chain Slack Adjustment	10-4
Wheel Alignment Adjustment	10-4
Drive Chain Wear Inspection	10-5
Lubrication	10-5
Drive Chain Removal	10-5
Drive Chain Installation	10-6
Sprocket, Coupling	10-6
Engine Sprocket Removal	10-6
Engine Sprocket Installation	10-7
Rear Sprocket Removal	10-7
Rear Sprocket Installation	10-7
Sprocket Warp	10-7
Coupling Installation Notes	10-8

10-2 FINAL DRIVE

Exploded View

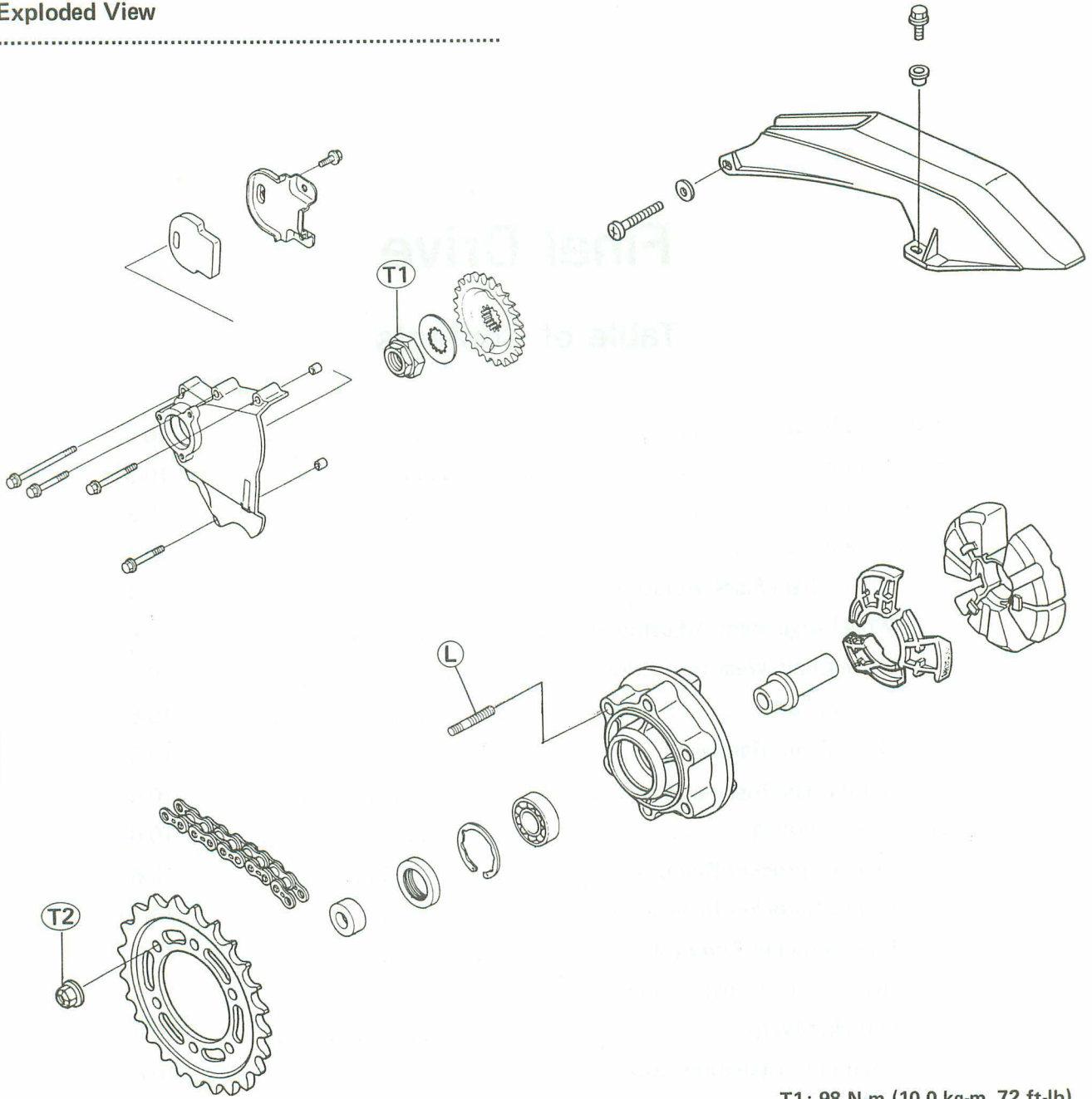

T1: 98 N-m (10.0 kg-m, 72 ft-lb)
T2: 74 N-m (7.5 kg-m, 54 ft-lb)

.....
Specifications

Item	Standard	Service Limit
Drive Chain:		
Make and type	Enuma Endless EK532ZV-O 110 Link	--- ---
Chain slack	30 – 40 mm	Less than 30 mm, or more than 45 mm
20-Link length	317.5 – 318.4 mm	323 mm
Sprockets:		
Rear sprocket warp	Under 0.4 mm	0.5 mm

.....
Special Tools

Bearing Driver Set: 57001-1129

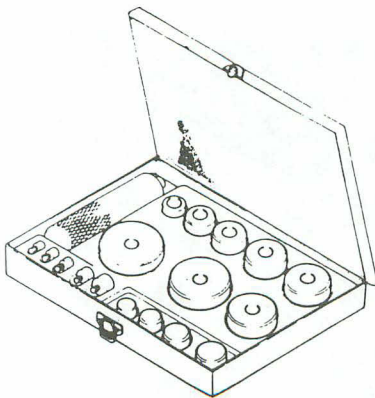

Circlip Pliers: 57001-143

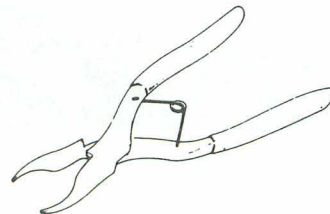

10-4 FINAL DRIVE

Drive Chain

Drive Chain Slack Adjustment

- Set the motorcycle up on its center stand, and check the chain slack within the standard value.
- Check to see if wheel alignment is properly adjusted.

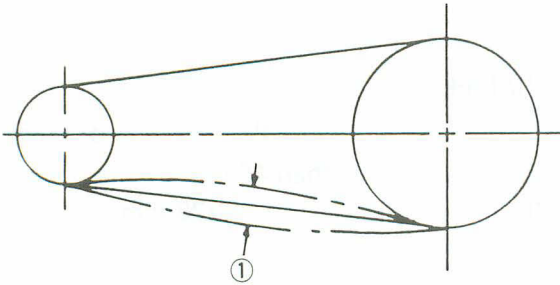

1. Chain Slack

Drive Chain Slack

Standard: 30 – 40 mm

- Loosen the following bolt and nut.
 - Torque Link Nut
 - Left and Right Chain Adjust Clamp Bolts

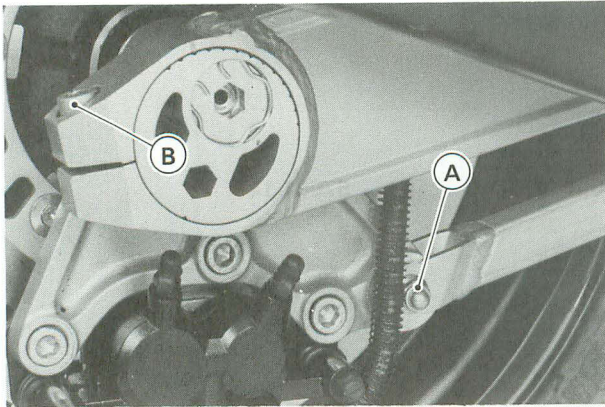

A. Torque Link Nut B. Chain Adjuster Clamp Bolt

- Turn the chain adjusters forward or rearward with an Allen wrench until the drive chain has the correct amount of chain slack.

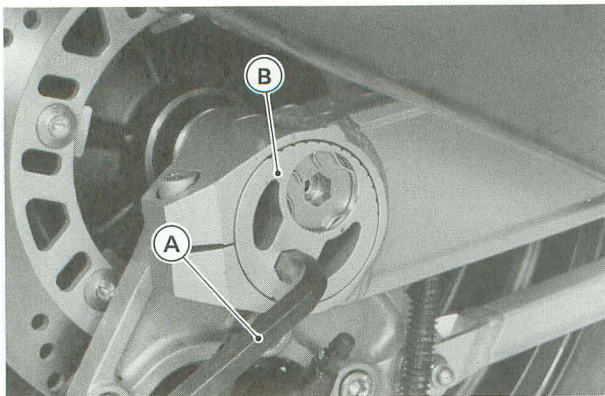

A. Allen Wrench B. Chain Adjuster

- The left and right notches on the swing arm should point to the same marks or positions on the left and right adjusters.

WARNING

- **Misalignment of the wheel will result in abnormal wear, and may result in an unsafe riding condition.**
- Tighten the following fasteners to the specified torque (see Exploded View).
 - Chain Adjuster Clamp Bolts
 - Torque Link Nut

WARNING

- **If the clamp bolts are not securely tightened, an unsafe riding condition may result.**

Wheel Alignment Adjustment

- Set the motorcycle up on its center stand.
- Check to see if wheel alignment is properly adjusted. The left and right notches on the swing arm should point to the same marks or positions on the left and right adjusters.

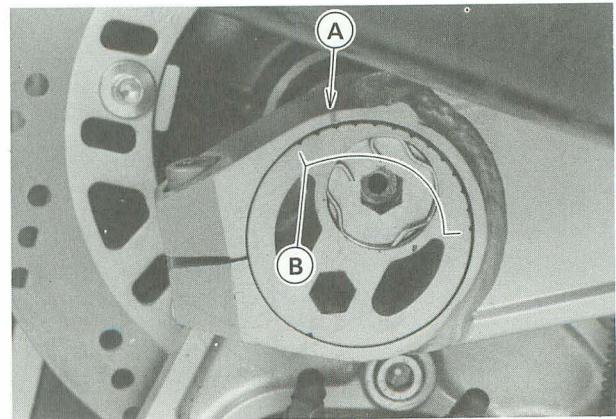

A. Swing Arm Notch B. Marks

- Remove the right retaining ring.
- Loosen the following bolt and nuts.
 - Axle Nut
 - Torque Link Nut
 - Right Chain Adjuster Clamp Bolt

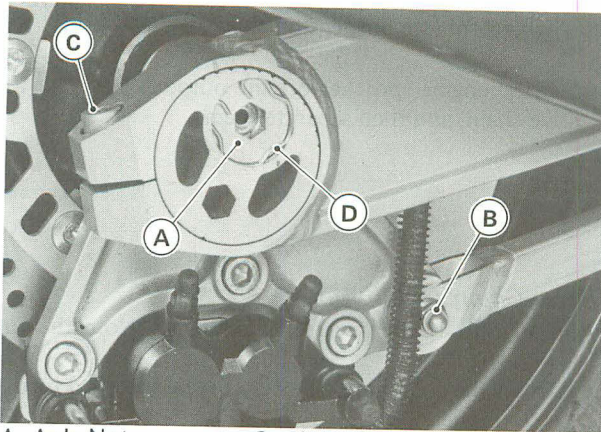

A. Axle Nut C. Chain Adjuster Clamp Bolt
B. Torque Link Nut D. Retaining Ring

- Turn the chain adjuster so that the left and right notches on the swing arm point to the same marks or positions on the left and right adjuster.
- Tighten the following bolt and nuts to the specified torque (see Exploded View).
Axle Nut (see Wheels/Tires chapter)
Right Chain Adjuster Clamp Bolt
Torque Link Nut
- Insert the retaining ring to secure the axle shaft.

WARNING

- If the axle nut or clamp bolts are not securely tightened or the retaining ring is not installed, an unsafe riding condition may result.

Drive Chain Wear Inspection

- Stretch the chain taut hanging a 98 N (10 kg, 20 lb) weight on the chain.
- Measure the length of 20 links on the straight part of the chain from pin center of the 1st pin to pin center of the 21st pin. Since the chain may wear unevenly, take measurement at several places.

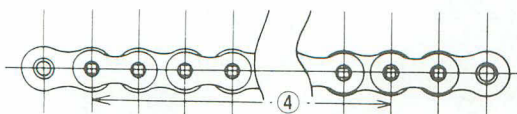
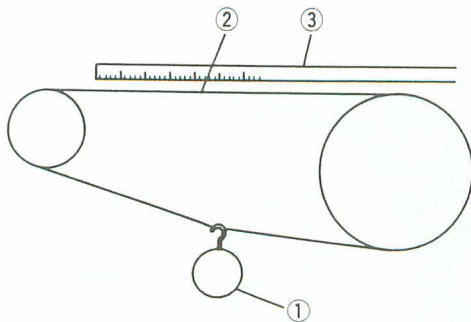

1. Weight 3. Ruler
2. Straight Part 4. Measure this length.

Drive Chain 20-Link Length

Standard:	317.5 – 318.4 mm
Service Limit:	323 mm

- ★ If any measurement exceeds the service limit, replace the chain. Also, replace the engine and rear sprockets when the drive chain is replaced.

WARNING

- For safety, use only the standard chain. It is an endless type and should not be cut for installation.

Lubrication

CAUTION

- The O-rings between the side plates seal in the lubricant between the pin and the bushing. To avoid damaging the O-rings and resultant loss of lubricant, observe the following rules.
- Use only kerosene or diesel oil for cleaning an O-ring drive chain. Any other cleaning solution such as gasoline or trichloroethylene will cause deterioration and swelling of the O-rings.
- Immediately blow the chain dry with compressed air after cleaning.
- Complete cleaning and drying the chain within 10 minutes.
- If a special lubricant is not available, a heavy oil such as SEA90 is preferred to a lightly oil because it will stay on the chain longer and provide better lubrication.

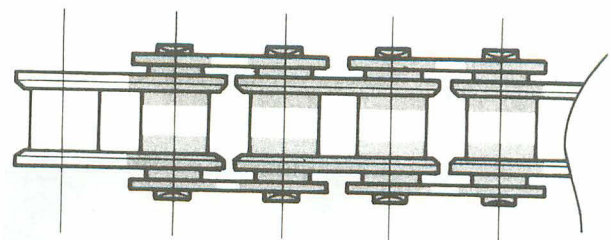

■ Oil Applied Areas

Drive Chain Removal

- Remove the following.
Clutch Slave Cylinder (see Clutch chapter)
Sprocket Cover
Engine Sprocket Nut

10-6 FINAL DRIVE

NOTE

○When loosening the engine sprocket nut, insert the steel rod into the rod hole to hold the sprocket.

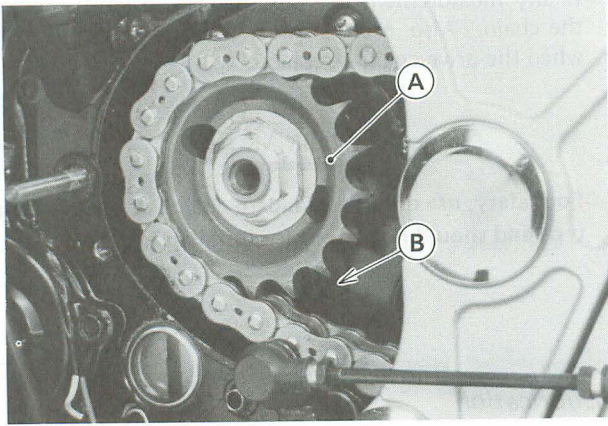

A. Engine Sprocket B. Rod Hole

Rear Wheel (see Wheels/Tires)
Right Footpeg Bracket

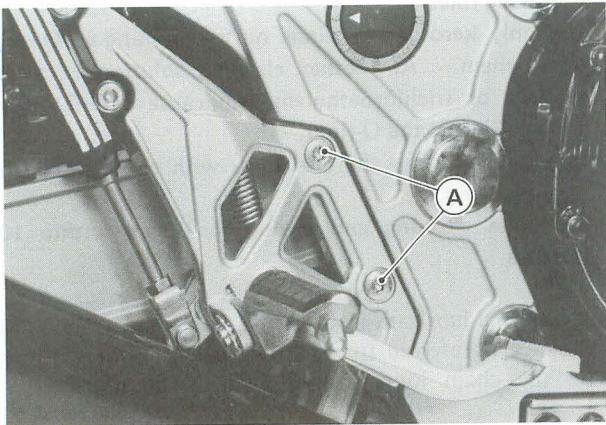

A. Bolts

Torque Link

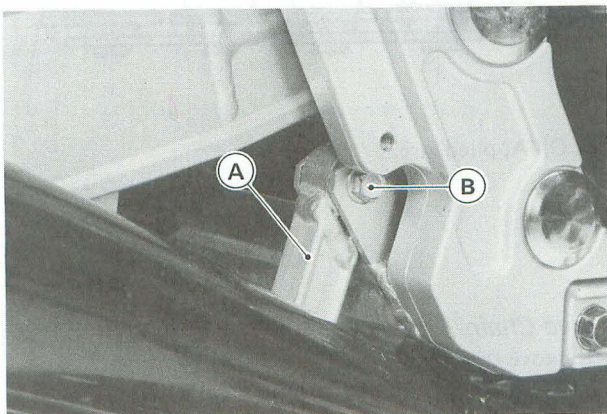

A. Torque Link B. Bolt

Swing Arm (see Suspension chapter)

- Pull the engine sprocket off the output shaft with the drive chain, and then separate them.

Drive Chain Installation

- Installation is the reverse of removal. Note the following.
- Tighten the following fasteners to the specified torque (see Exploded View).
 - Engine Sprocket Nut
 - Swing Arm Pivot Nut (see Suspension chapter)
 - Shock Absorber Nut (see Suspension chapter)
 - Uni-trak Tie-rod Nut (see Suspension chapter)
- Install the rear wheel (see Wheels/Tires chapter).
- Adjust the drive chain after installation.

Sprocket, Coupling

Engine Sprocket Removal

- Loosen the drive chain.
- Remove the following.
 - Clutch Slave Cylinder (see Clutch chapter)
 - Sprocket Cover
 - Engine Sprocket Nut

NOTE

○When loosening the engine sprocket nut, insert the steel rod into the rod hole to hold the sprocket.

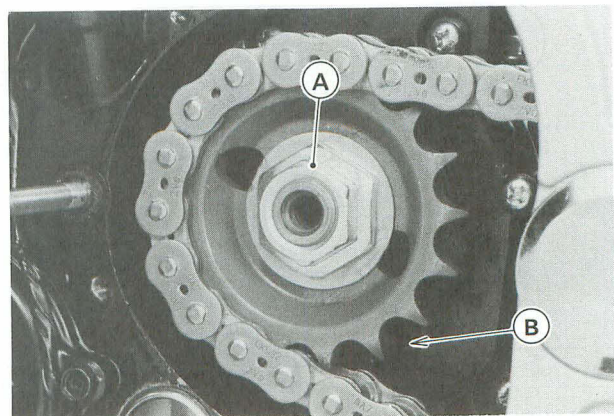

A. Engine Sprocket Nut B. Rod Hole

- Remove the drive chain from the rear sprocket.

NOTE

○ If it is difficult to remove the drive chain from the rear sprocket, remove the rear axle (see *Wheels/Tires* chapter).

- Pull the engine sprocket off the output shaft.

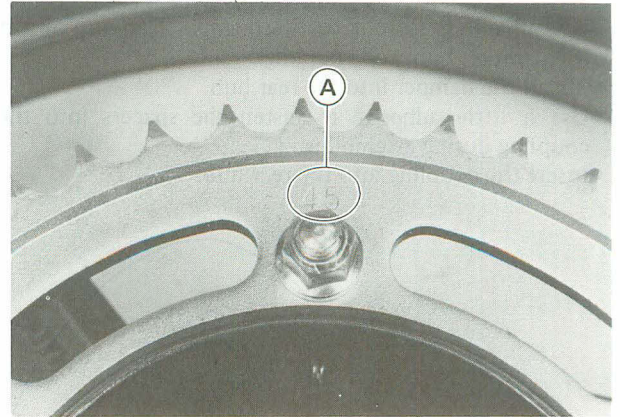

A. Tooth Number Marking

Engine Sprocket Installation

- Installation is the reverse of removal. Note the following.
- Tighten the following fasteners to the specified torque (see Exploded View).
 - Engine Sprocket Nut
 - Axle Clamp Bolts (see *Suspension* chapter)
 - Torque Link Nut (see *Brakes* chapter)
- Bend the lockwasher after tightening the engine sprocket nut.

- Tighten the rear sprocket nuts to the specified torque (see Exploded View).
- Install the rear wheel (see *Wheels/Tires* chapter).

Rear Sprocket Removal

- Remove the rear wheel (see *Wheels/Tires* chapter).

CAUTION

○ Do not lay the wheel on the ground with the disc facing down. This can damage or warp the disc. Place blocks under the wheel so the disc does not touch the ground.

- Remove the rear sprocket nuts.
- Remove the rear sprocket.

Rear Sprocket Installation

- Installation is the reverse of removal. Note the following.
- Install the sprocket facing the tooth number marking outward.

Sprocket Warp

Elevate the rear wheel so that it will turn freely, and set a dial gauge against the rear sprocket near the teeth as shown. Rotate the rear wheel. The difference between the highest and lowest dial gauge readings is the amount of runout (warp).

If the runout exceeds the service limit, replace the rear sprocket.

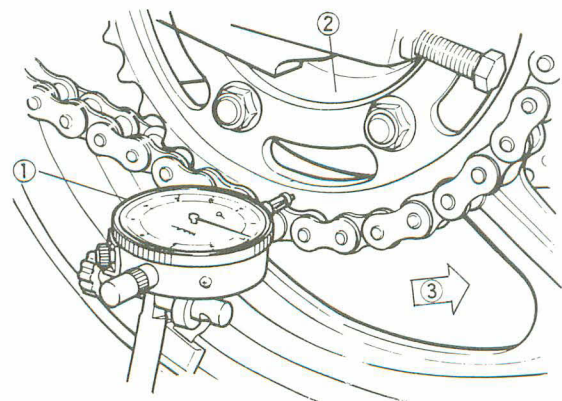

- 1. Dial Gauge
- 2. Rear Sprocket
- 3. Turn.

Rear Sprocket Warp

Standard:	Under 0.4 mm
Service Limit:	0.5 mm

10-8 FINAL DRIVE

Coupling Installation Notes

- Use an oilless solvent to thoroughly clean any oil off the damper, hub, and coupling.
- Install the damper into the rear hub.
- Use a little adhesive to fasten the spacers into the coupling during assembling.
- Insert the coupling into the rear hub.

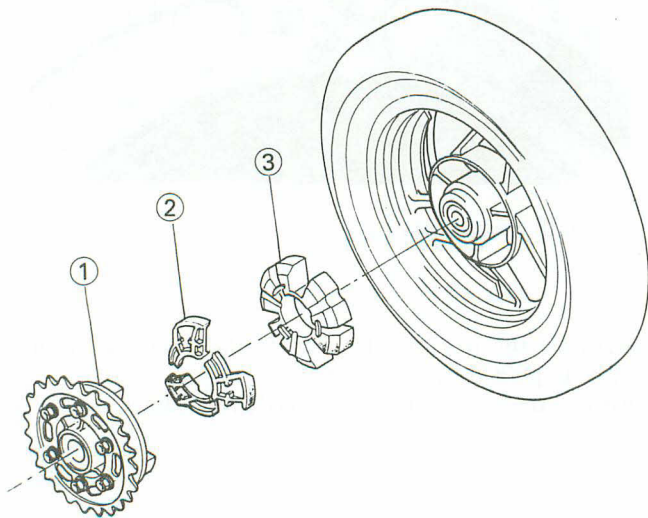

1. Coupling
2. Spacer

3. Damper

NOTE

○ Always use a soap and water solution to ease inserting the coupling into the hub. Never use such lubricant that leaves oily residue.

Brakes

Table of Contents

Exploded View	11-2
Specifications	11-4
Special Tool	11-4
Brake Pedal	11-5
Brake Light Switch Adjustment	11-5
Brake Pedal Position Adjustment	11-5
Caliper	11-6
Front Caliper Removal	11-6
Rear Caliper Removal	11-6
Caliper Installation	11-6
Disassembly Notes	11-6
Assembly Notes	11-7
Brake Pads	11-7
Removal	11-7
Installation Notes	11-7
Lining Wear	11-7
Master Cylinders	11-7
Front Master Cylinder Installation	11-7
Rear Master Cylinder Removal Note	11-8
Rear Master Cylinder Installation Note	11-8
Inspection and Adjustment after Installation	11-8
Disassembly	11-8
Assembly	11-8
Inspection (Visually)	11-9
Brake Disc	11-9
Wear	11-9
Warp	11-9
Brake Fluid	11-10
Fluid Level Inspection	11-10
Brake Fluid Change	11-10
Bleeding the Brake Line	11-11

11-2 BRAKES

Exploded View

- T1: 1.5 N-m (0.15 kg-m, 13 in-lb)
- T2: 8.8 N-m (0.9 kg-m, 78 in-lb)
- T3: 11 N-m (1.1 kg-m, 95 in-lb)
- T4: 25 N-m (2.5 kg-m, 18.0 ft-lb)
- T5: 7.8 N-m (0.80 kg-m, 69 in-lb)
- T6: 34 N-m (3.5 kg-m, 25 ft-lb)
- T7: 23 N-m (2.3 kg-m, 16.5 ft-lb)
- T8: 5.9 N-m (0.60 kg-m, 52 in-lb)
- G : Apply grease.

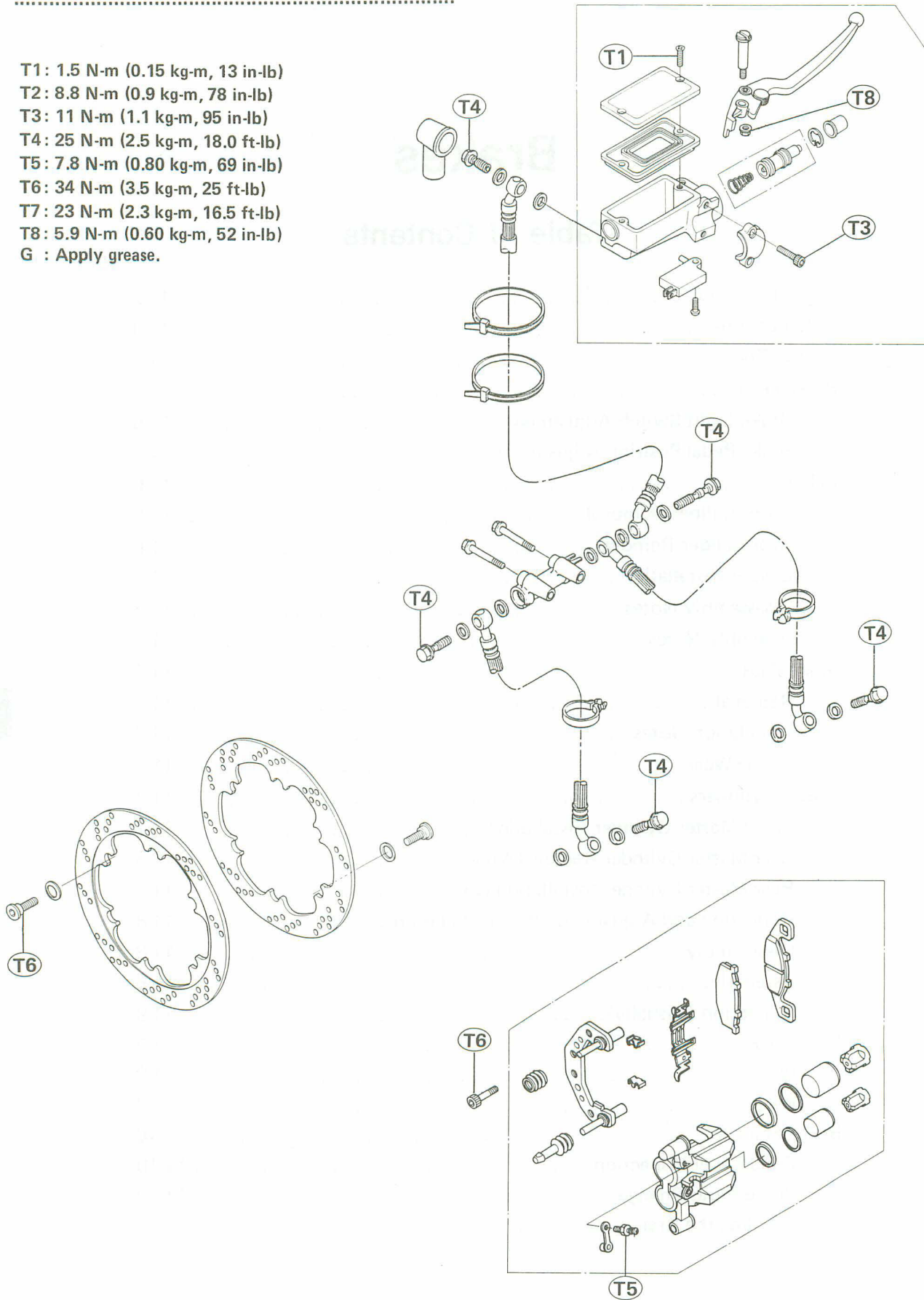

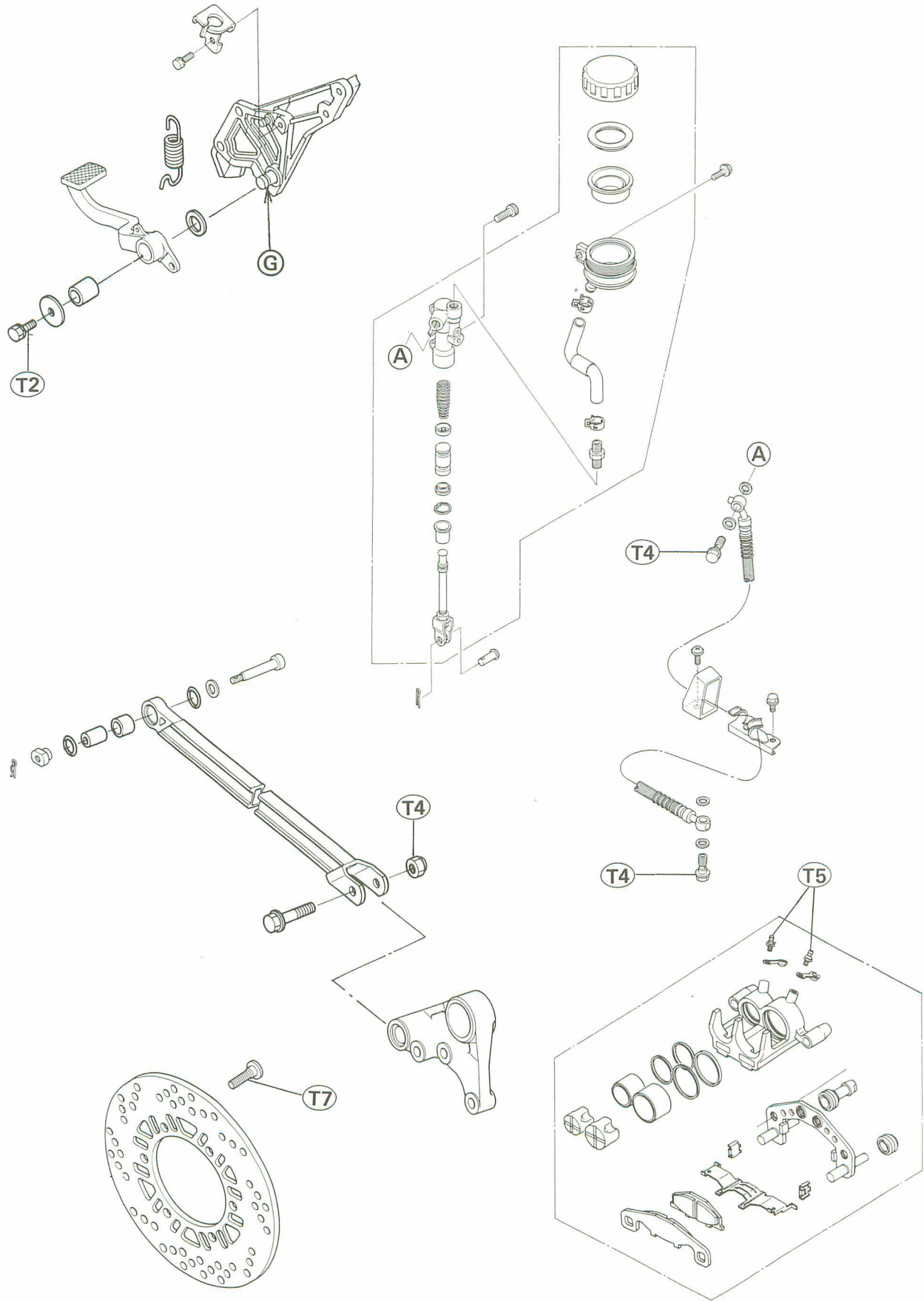

11-4 BRAKES

.....
Specifications
.....

Item	Standard	Service Limit
Brake Pedal: Brake pedal position	45 mm below top of footpeg	— — —
Brake Pads: Pad lining thickness	4.5 mm	1 mm
Brake Discs: Disc thickness: Front Rear Disc runout	4.8 – 5.1 mm 5.8 – 6.1 mm Under 0.15 mm	4.5 mm 5.0 mm 0.3 mm
Brake Fluid: Grade Brand (recommended)	D.O.T.4 Castrol Girling-Universal Castrol GT (LMA) Castrol Disc Brake Fluid Check Shock Premium Heavy Duty	

.....
Special Tools
.....

Circlip Pliers: 57001-143

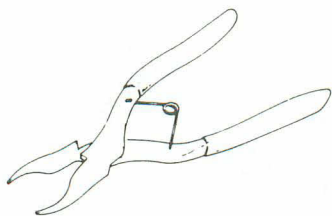

Brake Pedal

Brake Pedal Position Adjustment

- Check that the brake pedal is in the correct position.

Pedal Position

Standard: About 45 mm below top of footpeg

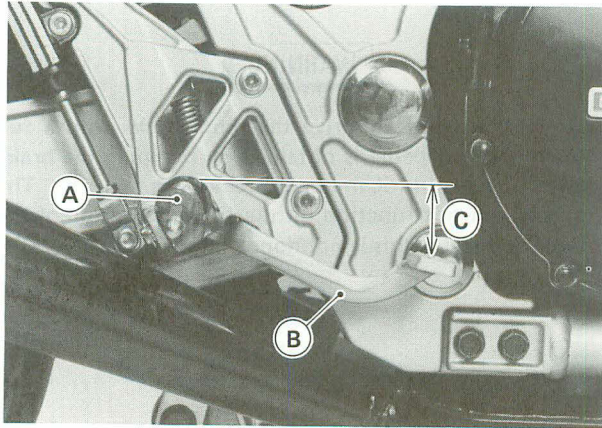

A. Footpeg
B. Brake Pedal
C. Pedal Position

NOTE

○ Usually it's not necessary to adjust the pedal position, but always adjust it when the master cylinder is disassembled.

○ If the pedal position cannot be adjusted by turning the clevis, the brake pedal may be deformed or incorrectly installed.

● When the brake pedal is in its rest position, measure the length (A) indicated in the figure.

★ If the length (A) is not within the specified length, adjust a nut.

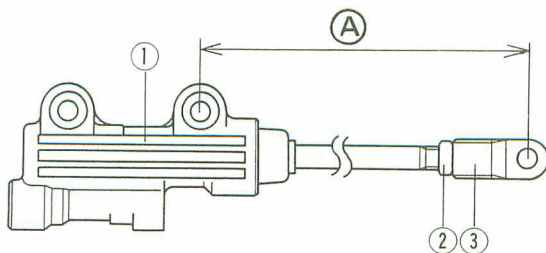

1. Master Cylinder
2. Locknut
3. Clevis

Length (A)

Standard: 119 ±1 mm

Rear Brake Light Switch Adjustment

- Check the operation of the rear brake light switch by depressing the brake pedal. The brake light should go on after about 10 mm of pedal travel.

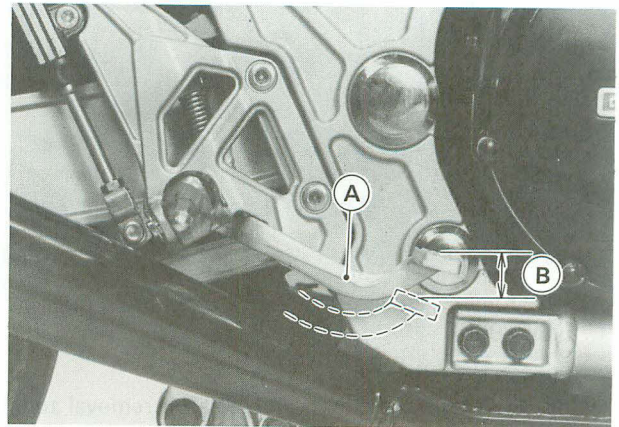

A. Brake Pedal
B. 10 mm

★ If it does not, adjust the brake light switch.

- Turn the adjusting nut to adjust the switch.

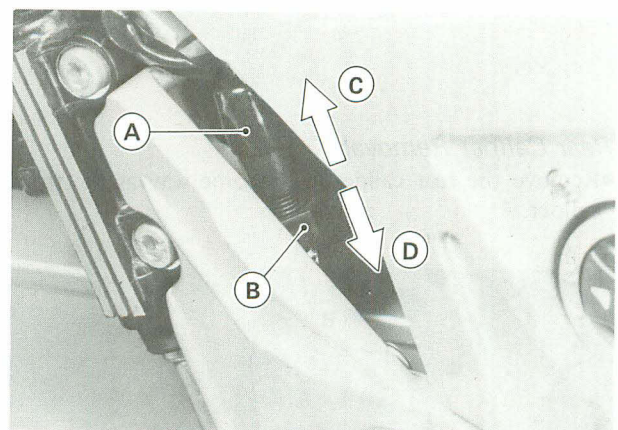

A. Switch
B. Adjusting Nut
C. Light sooner.
D. Light later.

CAUTION

○ To avoid damaging the electrical connections inside the switch be sure that the switch body does not turn during adjustment.

11-6 BRAKES

Caliper

Front Caliper Removal

- Remove the following.
 - Banjo Bolt (at the caliper)
 - Caliper Mounting Bolts

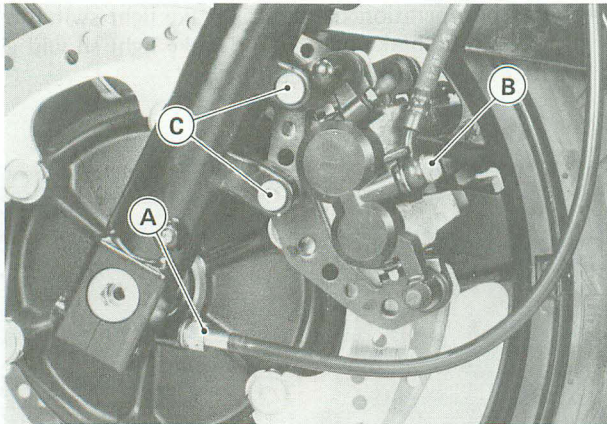

A. Speedometer Cable C. Caliper Mounting Bolts
B. Banjo Bolt

- ★ If the caliper is to be disassembled after removal and if compressed air is not available, remove the piston using the following steps before disconnecting the brake hose from the caliper.
 - Remove the pads.
 - Pump the brake lever to remove the caliper piston.

NOTE

- Immediately wipe up any brake fluid that spills.

Rear Caliper Removal

- Remove the rear caliper in the same way as the front caliper.

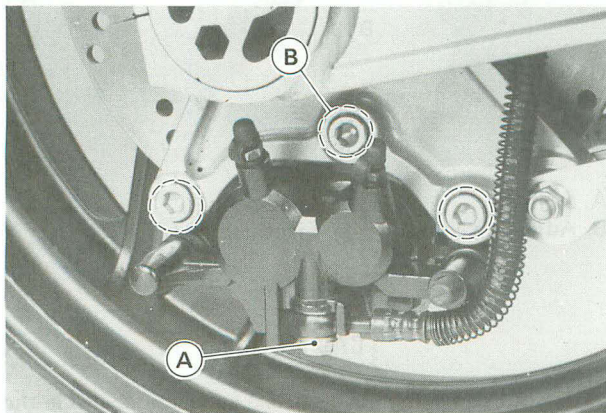

A. Banjo Bolt B. Caliper Mounting Bolts

Caliper Installation

- Note the following.
 - Tighten the caliper mounting bolts to the specified torque (see Exploded View).
 - Connect the brake hose to the caliper putting a new flat washer on each side of the brake hose fitting.
 - Tighten the banjo bolt to the specified torque (see Exploded View).
 - Check the fluid level in the master cylinder (reservoir), and bleed the brake line (see Bleeding the Brake).
 - Check the brake for weak braking power, brake drag, and fluid leakage.

WARNING

- Do not attempt to drive the motorcycle until a full brake lever or pedal is obtained by pumping the brake lever or pedal until the pads are against the disc. The brakes will not function on the first application of the lever or pedal if this is not done.

Disassembly Notes

- Using compressed air, remove the piston.
 - Cover the caliper opening with a clean, heavy cloth.
 - Remove the piston by lightly applying compressed air to where the brake line fits into the caliper.

WARNING

- To avoid serious injury, never place your fingers or palm inside the caliper opening. If you apply compressed air into the caliper, the piston may crush your hand or fingers.

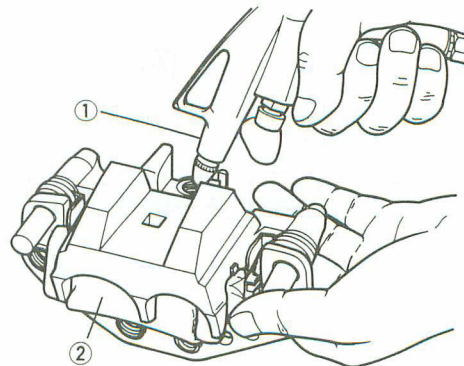

1. Apply compressed air 2. Cloth

Assembly Notes

- Apply brake fluid to the outside of the piston and the fluid seal, and push the piston into the cylinder by hand. Take care that neither the cylinder nor the piston skirt get scratched.
- Apply a thin coat of PBC (Poly Butyl Cuprysil) grease to the caliper holder shafts and holder holes. (PBC is a special high temperature, water-resistant grease).
- Install the anti-rattle spring in the calipers as shown.

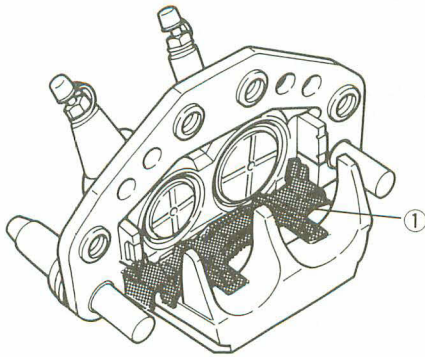

1. Anti-rattle Spring

Installation Notes

- Push the caliper pistons in by hand as far as they will go.

WARNING

- Do not attempt to drive the motorcycle until a full brake lever or pedal is obtained by pumping the brake lever or pedal until the pads are against the disc. The brake will not function on the first application of the lever or pedal if this is not done.

Lining Wear

- ★If the lining thickness of either pad is less than the service limit, replace both pads in the caliper as a set.

Pad Lining Thickness

Standard:	4.5 mm
Service Limit:	1 mm

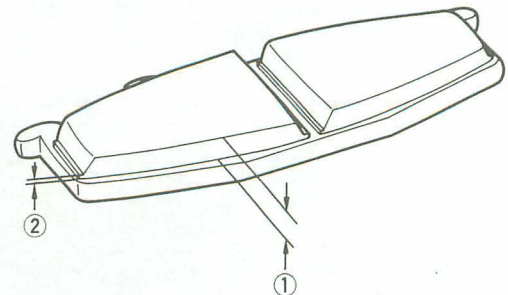

1. Lining Thickness
2. Service Limit

Brake Pads

Removal

- Remove the caliper (see Front or Rear Caliper Removal).
- Take off the piston side pad from the caliper holder.
- Push the caliper holder to the piston side, and then remove the pad from the caliper holder shaft.

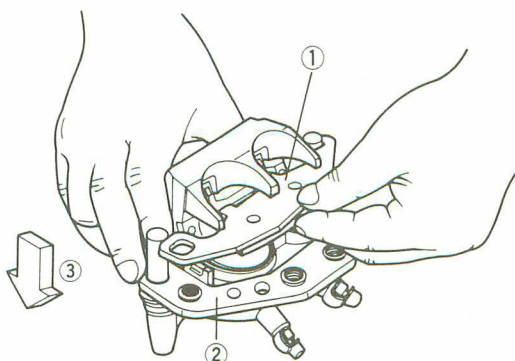

1. Pad
2. Caliper Holder
3. Push the caliper holder.

Master Cylinder

Front Master Cylinder Installation

- The master cylinder clamp must be installed with the arrow mark upward.
- Torque the upper clamp bolt first, and then the lower clamp bolt to the specification (see Exploded View). There will be a gap at the lower part of the clamp after tightening.

11-8 BRAKES

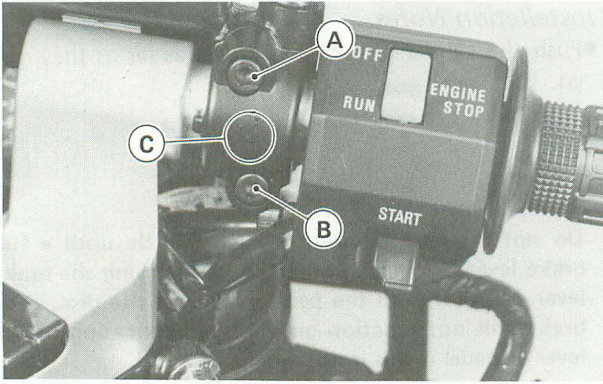

- A. Tighten upper clamp bolts first.
- B. Lower Clamp Bolt
- C. Arrow Mark

- Use a new flat washer on each side of the brake hose fitting.
- Tighten the banjo bolts to the specified torque (see Exploded View).

Rear Master Cylinder Removal Note

- Remove the cotter pin and then pull the joint pin out of the push rod clevis and brake pedal.

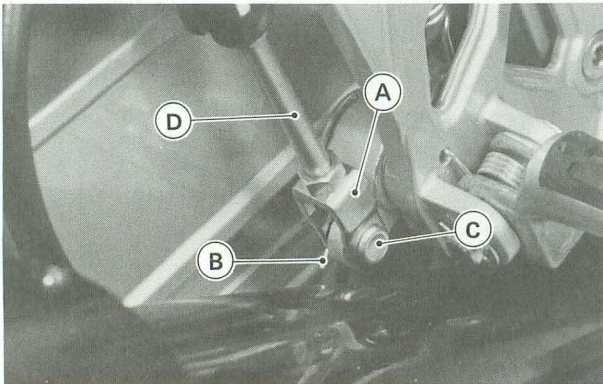

- A. Clevis
- B. Cotter Pin
- C. Joint Pin
- D. Push Rod

Rear Master Cylinder Installation Notes

- Use a new flat washer on each side of the brake hose fitting. Be sure that the metal pipe is properly fitted into the projection on the master cylinder.

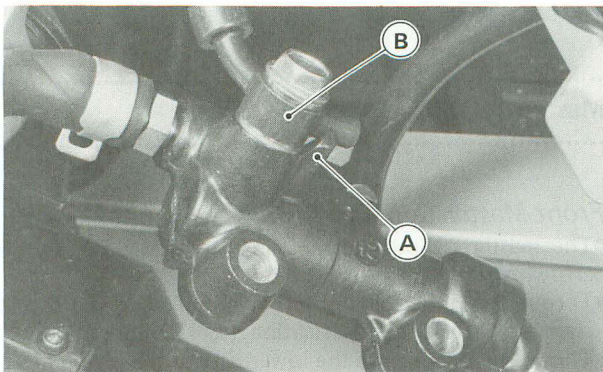

- A. Projection
- B. Metal Pipe

- Tighten the banjo bolts to the specified torque (see Exploded View).
- Tighten the rear master cylinder mounting bolts (2) to the specified torque (see Exploded View).

Inspection and Adjustment after Installation

- Check and adjust the following items after installation.
 - Brake Pedal Position
 - Rear Brake Light Switch Position
 - Brake Line Air Bleed
 - Brake Drag
 - Braking Power
 - Brake Fluid Leak

Disassembly

- Remove the following parts.
 - Dust Cover
 - Retainer
 - Piston with Secondary Cup
 - Primary Cup
 - Spring

CAUTION

- Do not remove the secondary cup from the piston since removal will damage them.

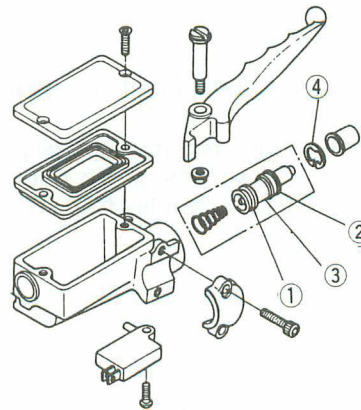

- 1. Primary Cup
- 2. Secondary Cup
- 3. Piston
- 4. Retainer

Assembly

- Note the following
 - Before assembly, clean all parts including the master cylinder with brake fluid or alcohol.
 - Apply brake fluid to the removed parts and to the inner wall of the cylinder.

CAUTION

○Except for the disc pads and disc; use only disc brake fluid, isopropyl alcohol, or ethyl alcohol, for cleaning brake parts. Do not use any other fluid for cleaning these parts. Gasoline, engine oil, or any other petroleum distillate will cause deterioration of the rubber parts. Oil spilled on any part will be difficult to wash off completely, and will eventually deteriorate the rubber use in the disc brake.

○Take care not to scratch the piston or the inner wall of the cylinder.

Inspection (Visually)

●Check that there are no scratches, wear, rust or pitting on the following parts.

- Inside of the Master Cylinder
- Outside of the Piston
- Primary Cups
- Secondary Cups
- Dust Covers
- Return Springs
- Relief and Supply Port Plugged

★If they are damaged, replace them.

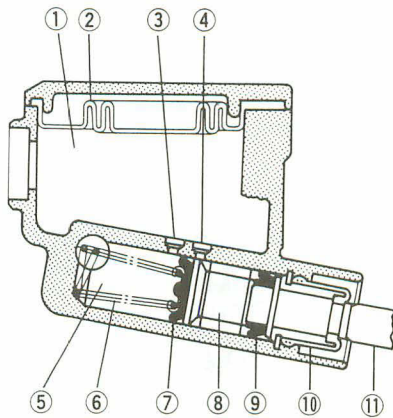

- | | |
|------------------|------------------|
| 1. Reservoir | 7. Primary Cup |
| 2. Diaphragm | 8. Piston |
| 3. Relief Port | 9. Secondary Cup |
| 4. Supply Port | 10. Dust Cover |
| 5. Cylinder | 11. Brake Lever |
| 6. Return Spring | |

Brake Disc

Wear

★Replace the disc if it has worn past the service limit.

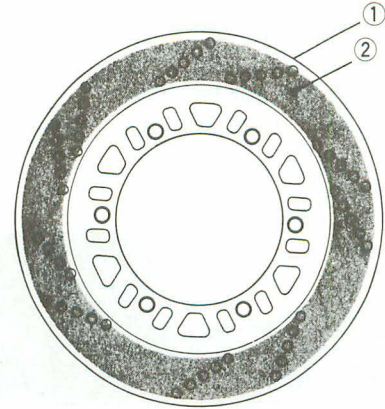

1. Brake Disc 2. Measuring Area

Front Disc Thickness

- | | |
|----------------------|---------------------|
| Standard: | 4.8 – 5.1 mm |
| Service Limit | 4.5 mm |

Rear Disc Thickness

- | | |
|-----------------------|---------------------|
| Standard: | 5.8 – 6.1 mm |
| Service Limit: | 5.0 mm |

Warp

★If runout exceeds the service limit, replace the disc.

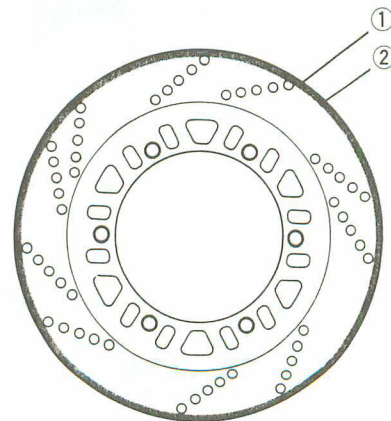

1. Brake Disc 2. Measuring Area

Disc Runout

- | | |
|-----------------------|---------------------|
| Standard: | Under 0.2 mm |
| Service Limit: | 0.3 mm |

11-10 BRAKES

Brake Fluid

Fluid Level Inspection

- Check the brake fluid level in the reservoir.

Front Brake Fluid Reservoir

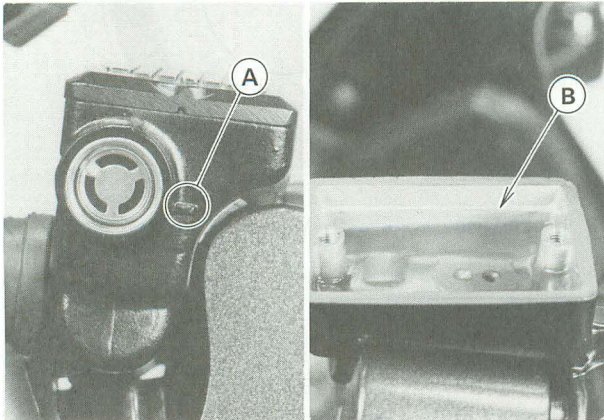

A. Lower Level Line B. Upper Level Line

Rear Brake Fluid Reservoir

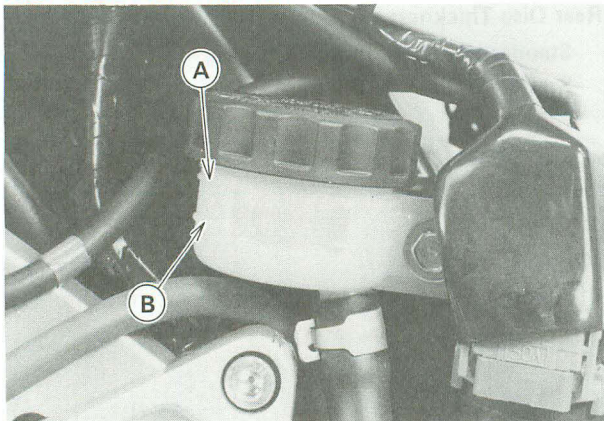

A. Upper Level Line B. Lower Level Line

NOTE

○ Hold the reservoir horizontal when checking brake fluid level.

★ If the fluid level is lower than the lower level line, fill the reservoir to the upper level line of the reservoir.

WARNING

○ Change the brake fluid in the brake line completely if the brake fluid must be refilled but the type and brand of the brake fluid that already is in the reservoir are unidentified. After changing the fluid, use only the same type and brand of fluid thereafter. Mixing different types and brands of brake fluid lowers the brake fluid boiling point and could cause the brake to be ineffective. It may also cause the rubber brake parts to deteriorate.

Recommended Disc Brake Fluid

Type	D.O.T.4
Brand	Check Shock Premium Heavy Duty Castrol Girling-Universal Castrol GT (LMA) Castrol Disc Brake Fluid

Brake Fluid Change

NOTE

○ The procedure to change the front brake fluid is as follows. Changing the rear brake fluid is the same as for the front brake.

- Remove the reservoir cap, and remove the rubber cap on the bleed valve.
- Attach a clear plastic hose to the bleed valve on the caliper, and run the other end of the hose into a container.
- Change the brake fluid as follows:

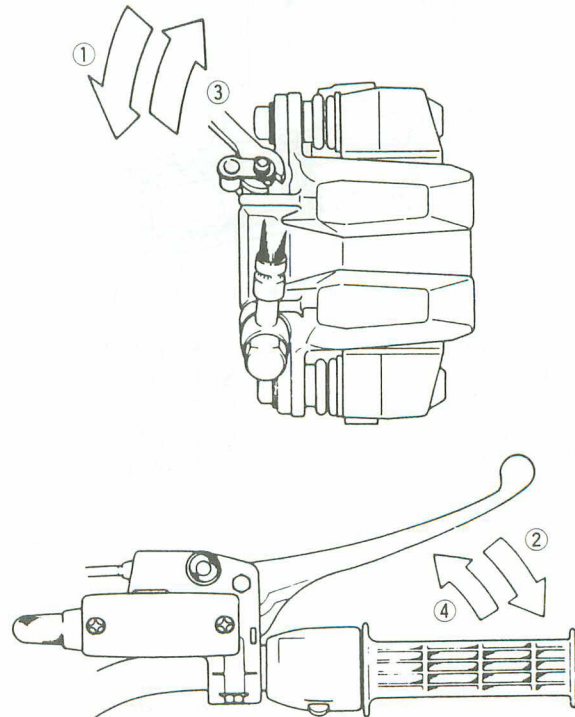

1. Open the bleed valve.
2. Apply the brake and hold it.
3. Close the bleed valve
4. Release the brake lever.

- Check the fluid level in the reservoir often, replenishing it as necessary.

NOTE

- *If the fluid in the reservoir runs completely out any time during fluid changing, the bleeding operation must be done over again from the beginning since air will have entered the line.*

- Repeat this operation until fresh brake fluid comes out from the plastic hose or the color of the fluid changes.

WARNING

- **Do not mix two brands of fluid. Change the brake fluid in the brake line completely if the brake fluid must be refilled but the type and brand of the brake fluid that is already in the reservoir are unidentified.**

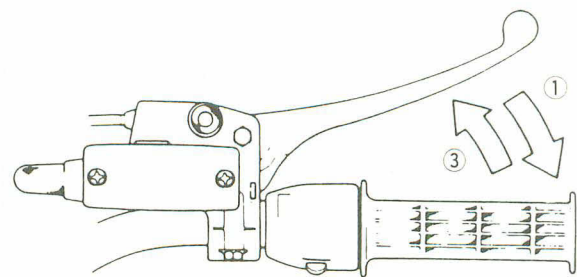
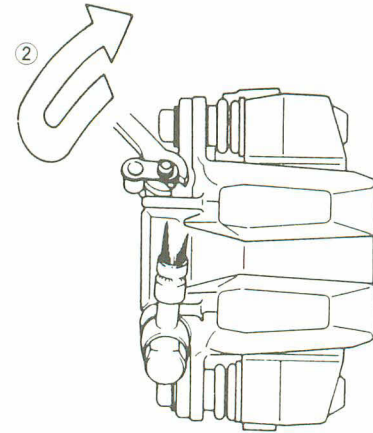
*Bleeding the Brake Line***NOTE**

- *The procedure to bleed the front brake line is as follows. Bleeding the rear brake line is the same as for the front brake.*

Bleed the air after the brake parts are removed or disassembled.

- With the reservoir cap off, fill the reservoir with fresh brake fluid.
- Slowly pump the brake lever or pedal several times until no air bubbles can be seen rising up through the fluid from the holes at the bottom of the reservoir. This bleeds the air from the master cylinder and the brake line.

NOTE

- *Tap the brake hose lightly going from the caliper to the reservoir side and let the air off from the reservoir when the brake lever has a spongy feeling.*

- Attach a clear plastic hose to the bleed valve on the caliper, and run the other end of the hose into a container.
- Bleed the brake line and the caliper as follows:

1. Hold the brake applied.
2. Quickly open and close the valve.
3. Release the brake.

- The fluid level must be checked several times during the bleeding operation and replenished as necessary.
- Repeat this operation until no more air can be seen coming out into the plastic hose.

NOTE

- *Front Brake: Repeat the above steps one more time for the other caliper.*
- *Rear Brake: Repeat the above steps one more time for the other bleed valve.*
- *If the brake lever action still feels soft or spongy, tap the brake hose with suitable mean from bottom to top end or air will rise up to the top part of the hose, slowly pump the brake lever as the same manner as above.*

- If the fluid in the reservoir runs completely out any time during bleeding, the bleeding operation must be done over again from the beginning since air will have entered the line.

11-12 BRAKES

WARNING

○When working with the disc brake, observe the precautions listed below.

1. Never reuse old brake fluid.
2. Do not use fluid from a container that has been left unsealed or that has been open for a long time.
3. Do not mix two types and brands of fluid for use in the brake. This lowers the brake fluid boiling point and could cause the brake to be ineffective. It may also cause the rubber brake parts to deteriorate.
4. Don't leave the reservoir cap off for any length of time to avoid moisture contamination of the fluid.
5. Don't change the fluid in the rain or when a strong wind is blowing.
6. Except for the disc pads and discs, use only disc brake fluid, isopropyl alcohol, or ethyl alcohol for cleaning brake parts. Do not use any other fluid for cleaning these parts. Gasoline, engine oil, or any other petroleum distillate will cause deterioration of the rubber parts. Oil spilled on any part will be difficult to wash off completely and will eventually deteriorate the rubber used in the disc brake.
7. When handling the disc pads or disc, be careful that no disc brake fluid or any oil gets on them. Clean off any fluid or oil that inadvertently gets on the pads or disc with a high flash-point solvent. Do not use one which will leave an oily residue. Replace the pads with new ones if they cannot be cleaned satisfactorily.
8. Brake fluid quickly ruins painted surfaces; any spilled fluid should be completely wiped up immediately.
9. If any of the brake line fittings or the bleed valve is opened at any time, the **AIR MUST BE BLED FROM THE BRAKE.**

Suspension

Table of Contents

Exploded View	12-2
Specifications	12-4
Special Tools	12-4
Front Fork	12-5
Fork Oil Change	12-5
Removal	12-5
Installation	12-6
Disassembly	12-6
Assembly	12-6
Inner Tube Inspection	12-7
Guide Bush Inspection	12-7
Oil Seal and Dust Seal Inspection	12-7
Spring Tension	12-7
Rear Suspension (Uni-trak)	12-8
Rear Shock Absorber	12-8
Air Pressure Adjustment	12-8
Damping Force Adjustment	12-8
Removal	12-9
Installation	12-9
Swing Arm	12-10
Removal	12-10
Installation	12-10
Tie-rod, Rocker Arm	12-11
Tie-rod Removal	12-11
Tie-rod Installation	12-11
Rocker Arm Removal	12-11
Rocker Arm Installation	12-11
Needle Bearing Inspection	12-11
Tie-rod, Rocker Arm Sleeve Inspection	12-11
Tie-rod, Rocker Arm Needle Bearing Lubrication	12-11

12-2 SUSPENSION

Exploded View

- T1: 23 N-m (2.3 kg-m, 16.5 ft-lb)
T2: 28 N-m (2.9 kg-m, 21 ft-lb)
T3: 1.5 N-m (0.15 kg-m, 13 in-lb)
T4: 39 N-m (4.0 kg-m, 29 ft-lb)
T5: 21 N-m (2.1 kg-m, 15.0 ft-lb)
LG: Apply liquid gasket
L : Apply a non-permanent locking agent

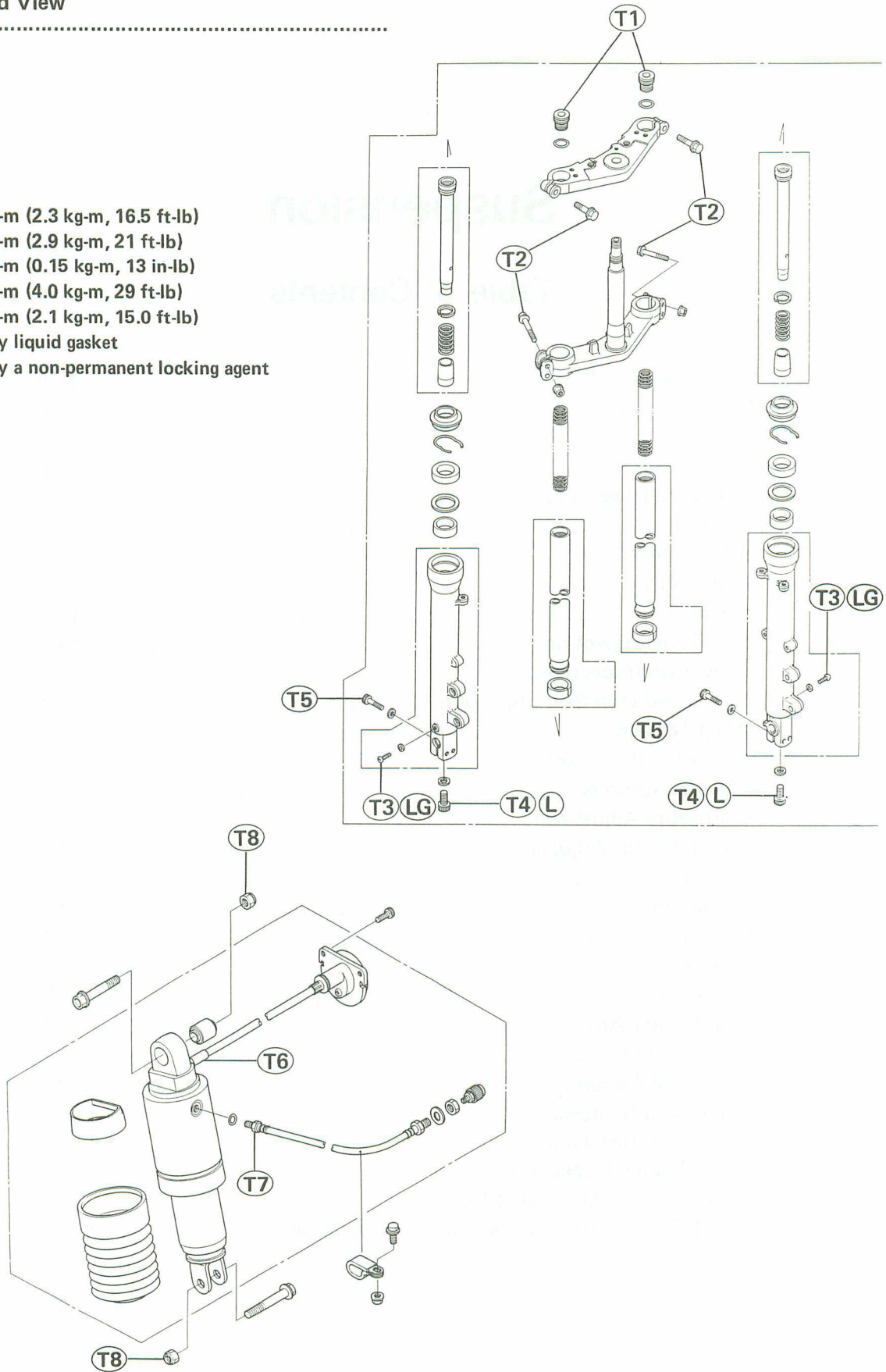

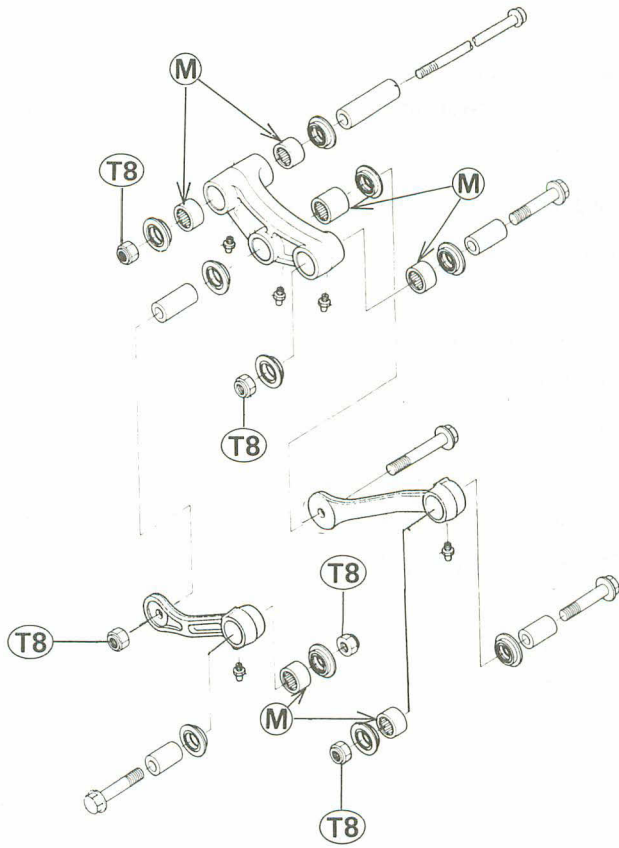

- T6: 8.8 N-m (0.90 kg-m, 78 in-lb)
- T7: 12 N-m (1.2 kg-m, 104 in-lb)
- T8: 59 N-m (6.0 kg-m, 43 ft-lb)
- T9: 88 N-m (9.0 kg-m, 65 ft-lb)
- M : Apply molybdenum disulfide grease.

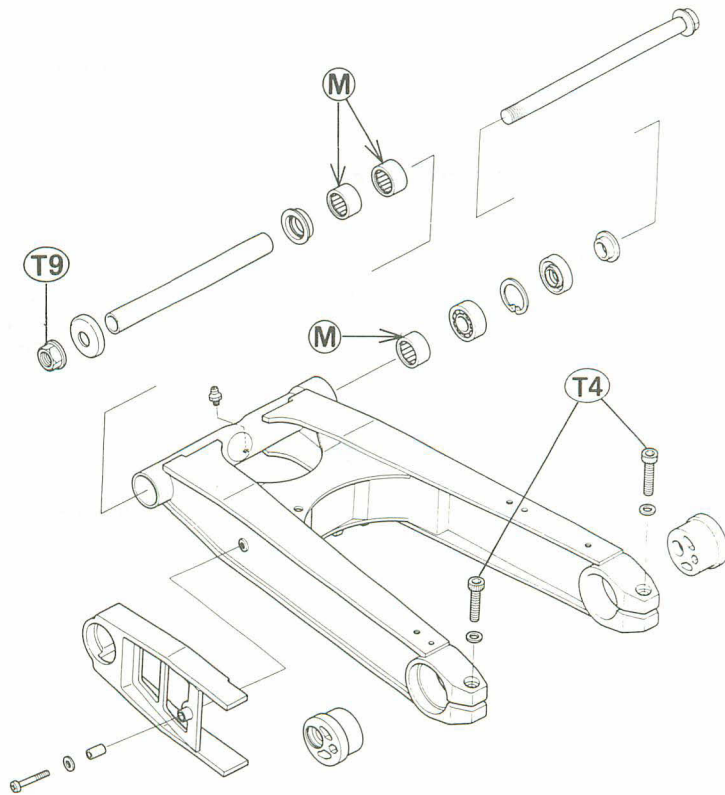

12-4 SUSPENSION

Specifications

Item	Standard	Service Limit
Front Fork:		
Fork Oil: Viscosity	SAE 10W20	---
Amount per Unit	419 ±4 mL	---
	360 mL : When changing oil	---
Fork oil level:	130 ±2 mm (Fully compressed without spring)	---
Fork spring free length	488 mm	478 mm
Rear Suspension:		
Rear shock absorber air pressure	0 (Atmospheric Pressure) 0 – 100 kPa (0 – 1.0 kg/cm ² , 14 psi)	
Rear shock absorber damper adjuster position	2 of 4 positions	

Special Tools

Front Fork Cylinder Holder Handle: 57001-183

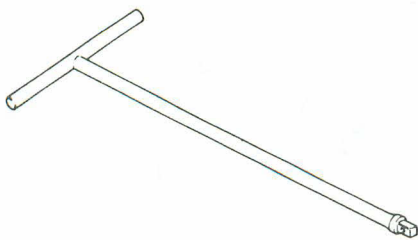

Front Fork Cylinder Holder Handle Adapter: 57001-1057



Bearing Driver Set: 57001-1129

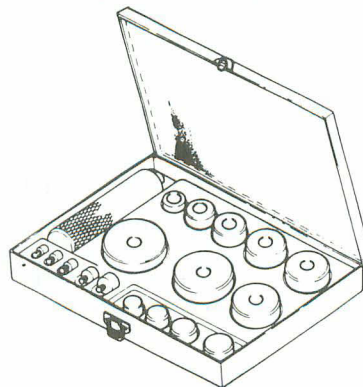

Front Outer Tube Weight: 57001-1218

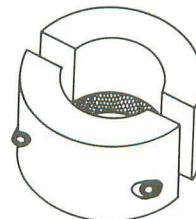

Front Oil Seal Driver: 57001-1219

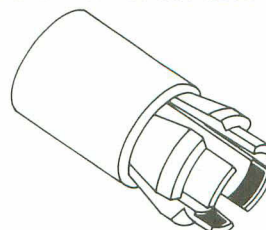

Front Fork

Fork Oil Change

- Remove the following.
 - Handlebar Holder
 - Fork Top Plug
 - Fork Spring
 - Drain Screw

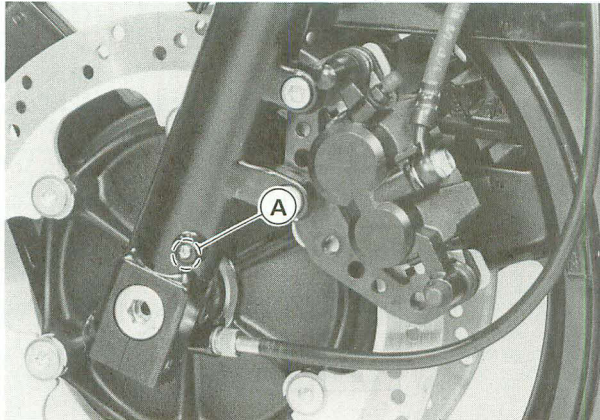

A. Drain Screw

- Allow the oil to drain into a suitable container. If you pump the fork legs to force out the oil, be sure to catch the oil in a container as it squirts out.

NOTE

- Apply a liquid gasket to the threads of the drain screw and gasket.

Front Fork Oil

Viscosity	SAE10W20
Amount per side	
When changing oil:	360 mL
After disassembly and completely dry:	419 ±4 mL

NOTE

- Pump the fork enough times to expel the air from the upper and lower chambers.

- With the fork fully compressed insert a tape measure or rod in the inner tube, and measure the distance from the top of the inner tube to the oil.

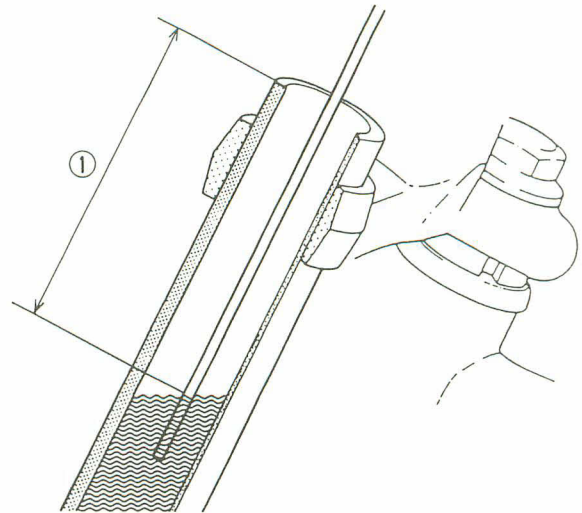

1. Oil Level

Fork Oil Level

(Fully Compressed without spring)

130 ±2 mm

- ★ If the oil is above or below the specified level, remove or add oil and recheck the oil level.
- Change the oil of the other fork leg in the same manner.

Removal

- Remove the following.
 - Fairings
 - Calipers
 - Front Wheel
 - Front Fender
- Loosen the upper and lower fork clamp bolts.
- With a twisting motion, work the fork leg down and out.

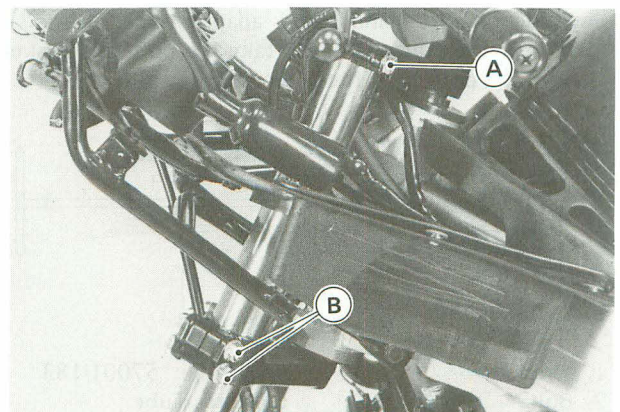

A. Upper Clamp Bolt B. Lower Clamp Bolts

12-6 SUSPENSION

Installation

- Installation is the reverse of removal. Note the following.
- If the fork leg was disassembled, check the fork oil level.
- Install the fork so that the top end of the inner tube projects 15 mm from the upper surface of the fork clamps.

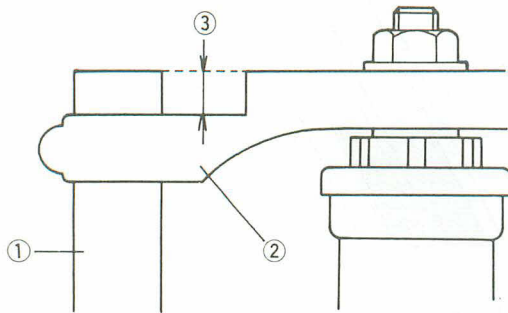

1. Inner Tube
2. Fork Clamps
3. 15 mm

- Tighten the upper and lower fork clamp bolts to the specified torque (see Exploded View).
- Tighten the caliper mounting bolts to the specified torque (see Exploded View in the Brake chapter).
- Check the front brake after installation.

WARNING

- Do not attempt to drive the motorcycle until a full brake lever is obtained by pumping the brake lever until the pads are against the disc. The brake will not function on the first application of the lever if this is not done.

Disassembly

- Loosen the top plug, before removing the front fork.
- Remove the front fork.
- Remove the top plug.
- Pour out the fork oil.
- Stop the cylinder from turning by using the front fork cylinder holder handle and adapter (special tools). Unscrew the Allen bolt and take the bolt, and gasket out of the bottom of the outer tube.

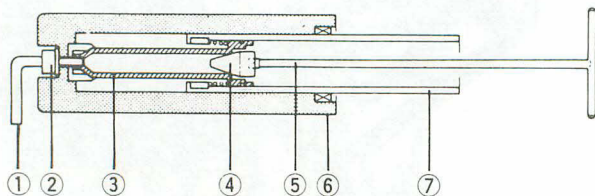

1. Wrench
2. Bolt
3. Cylinder
4. Adapter: 57001-1057
5. Handle: 57001-183
6. Outer Tube
7. Inner Tube

- Remove the piston and cylinder unit and the short spring from the top of the front fork tube.
- Remove the dust seal from the outer tube.
- Remove the retainer and washer from the outer tube.
- Mount the weight (special tool) on the top of the outer tube, by fitting the step of the weight (special tool) to the top corner of the outer tube.
- Holding the inner tube by hand in a vertical position, stroke the outer tube several times and pull it down.

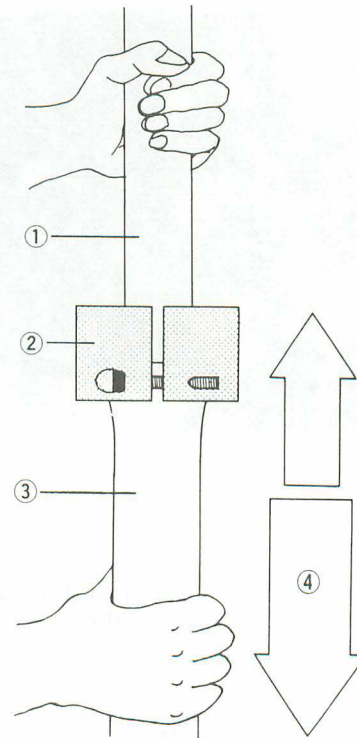

1. Inner Tube
2. Fork Outer Tube Weight: 57001-1218
3. Outer Tube
4. Stroke

- Take the cylinder base off the outer tube.

Assembly

- Assembly is the reverse of disassembly. Note the following.
- Check the following parts and replace them with new ones if necessary.
 - Top Plug O-Ring
 - Guide Bush
- Replace the oil seal removed with a new one.

- Apply a non-permanent locking agent to the Allen bolt and tighten it to the specified torque (see Exploded View).
- Install the guide bush (with a used guide bush on it) by tapping the used guide bush with the fork oil seal driver (special tool) until it stops. The slit of the bush must be faced toward the left or right.

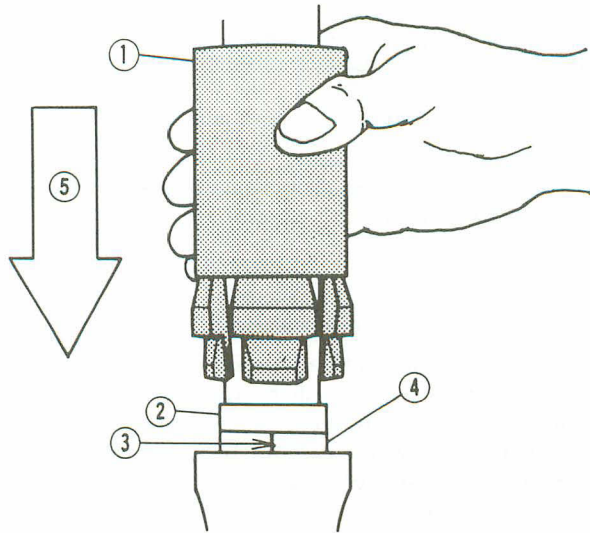

1. Driver: 57001-1219
2. Used Guide Bush
3. Slit (toward the left or right)
4. New Guide Bush
5. Tap

- Use the fork oil seal driver (special tool) to install the oil seal in the front fork.

Inner Tube Inspection

- ★ If the inner tube is damaged, replace it.
- Nicks or rust damage can sometimes be repaired by using a wet-stone to remove sharp edges or raised areas which cause seal damage.
- ★ If the damage is not repairable, replace the inner tube. Since damage to the inner tube damages the oil seal, replace the oil seal whenever the inner tube is repaired or replaced.

CAUTION

- If the inner tube is badly bent or creased, replace it. Excessive bending, followed by subsequent straightening, can weaken the inner tube.

Guide Bush Inspection

- ★ Replace the guide bushes if they are damaged or worn.

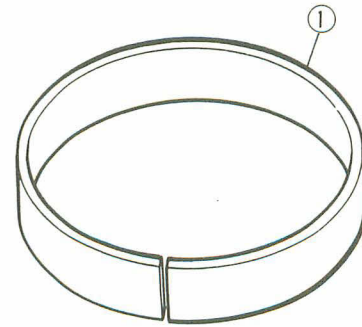

1. Guide Bush

Oil Seal and Dust Seal Inspection

- ★ If dust seal is any damage or wear, replace it.
- Replace the oil seal with a new one whenever it has been removed.

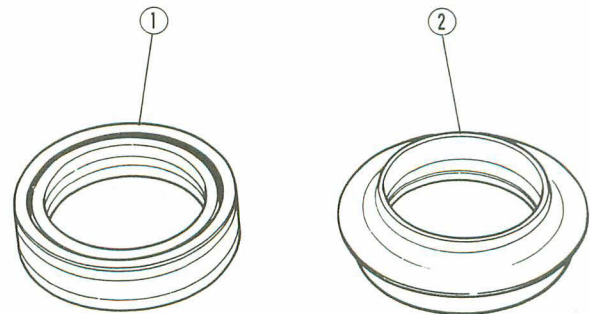

1. Oil Seal

2. Dust Seal

Spring Tension

- ★ If the spring of either fork leg is shorter than the service limit, it must be replaced. If the length of a replacement spring and that of the remaining spring vary greatly, the remaining spring should also be replaced in order to keep the fork legs balanced for motorcycle stability.

12-8 SUSPENSION

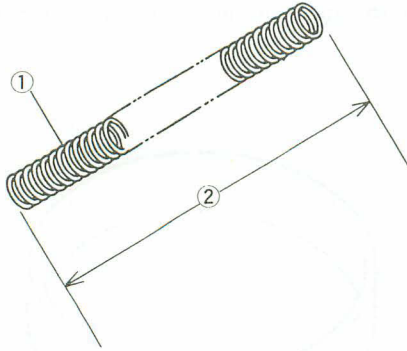

1. Fork Spring
2. Free Length

Fork Spring Length

Standard: 488 mm
 Service Limit: 478 mm

Rear Suspension (Uni-trak)

Rear Shock Absorber: Air Pressure Adjustment

- Note the following.

Put the motorcycle up on its center stand to raise the rear wheel off the ground. Use air pressure gauge 52005-1003 which is specially made for air suspensions. Check and adjust the air pressure when the rear shock absorber is cold (room temperature).

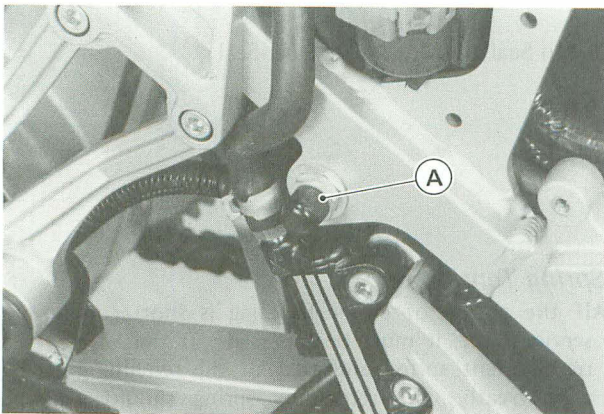

A. Air Valve

NOTE

- Do not use tire gauges for checking air pressure. They may not indicate the correct air pressure because of air leaks that occur when the gauge is applied to the valve.

Air Pressure kPa (kg/cm², psi)

	Usable Range
One Rider or Normal Riding	Atmospheric Pressure ~ 100 (1.0, 21)

NOTE

- The recommended air pressure is atmospheric pressure for average rider with no accessories.

WARNING

- Be sure to adjust the air pressure within the usable range. Pressure too high or too low can produce a hazardous riding condition.
- Only air or nitrogen gas can be used. Never inject oxygen or any kind of explosive gas.
- Do not incinerate the rear shock absorber.

Damping Force Adjustment

- Turn the damper adjusting dial to the desired number until you feel a click. The numbers on the adjuster show the setting position.

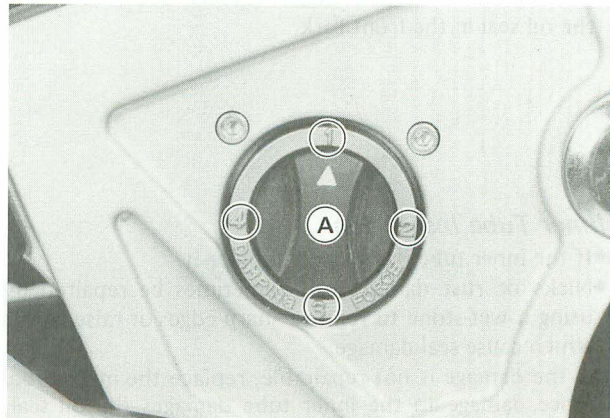

A. Adjusting Dial

NOTE

- The damping force can be left soft for average riding. But it should be adjusted harder for high speed riding, or riding with a passenger. If the damping feels too soft or too stiff, adjust it in accordance with the following table:

Rebound Damping Adjustment

Adjuster Position	Damping Force	Setting	Load	Road	Speed
1	Stronger ↓	Soft ↕ Hard	Light ↕ Heavy	Good ↕ Bad	Low ↕ High
2					
3					
4					

Removal

- Remove the following.
 - Seat
 - Side Cover
 - Rear Cowl
 - Battery
 - Rear Fender
- Remove the air valve mounting nut and free the air hose.
- Remove the damping adjuster mounting bolts.

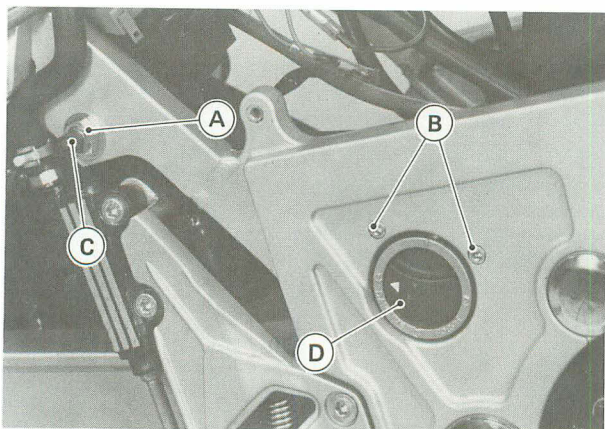

A. Mounting Nut C. Air Valve
B. Mounting Bolts D. Damping Adjuster

- Disconnect the damping adjuster cable from the adjuster.

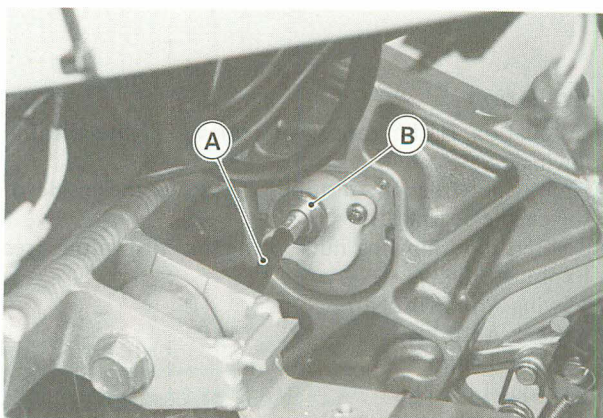

A. Damping Adjuster Cable B. Nut

- Remove the shock absorber bolts and tie-rod bolt.

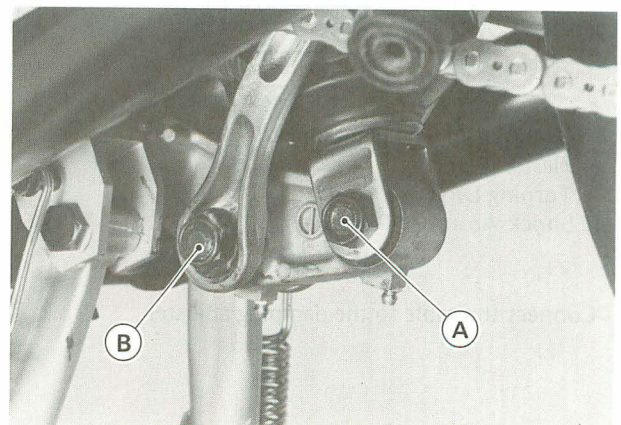
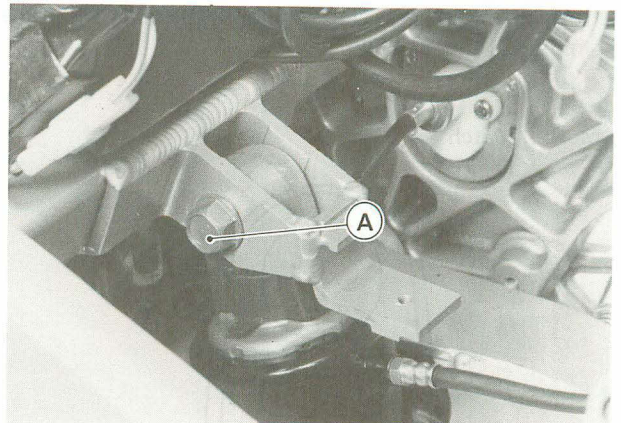

A. Shock Absorber Bolts
B. Tie-rod Bolt

- Remove the shock absorber toward the ground.

Installation

- Installation is the reverse of removal. Note the following.
- Apply molybdenum disulfide grease to the inside of the needle bearings.
- Tighten the shock absorber bolts and tie-rod bolt to the specified torque (see Exploded View).
- Set the damping adjuster as follows.
 - Turn the damping adjuster dial No.1 position.

12-10 SUSPENSION

- Slide the dust cover off the top of the shock absorber.
- Check that the gear mark I (red painted mark) is at the middle of the window.
- If the gear mark I is not at the middle of the window, turn the plastic gear clockwise until the mark I is in the middle of the window.

Mark I Match

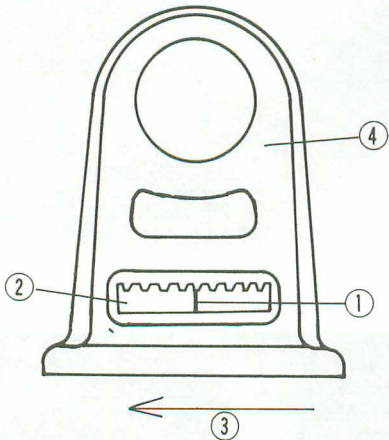

1. Gear Mark I (red painted mark)
2. Plastic Gear
3. Turning Direction
4. Shock Absorber Top

- Connect the cable to the damping adjuster.

Swing Arm: Removal

- Remove the following.
 - Rear Wheel
 - Brake Hose Guide
 - Chain Cover
 - Right Footpeg Bracket
 - Torque Link

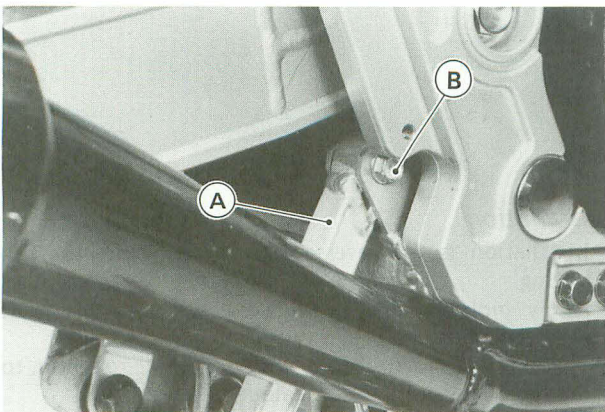

A. Torque Link

B. Bolt

Shock Absorber Bolt (lower) Tie-Rod Bolts

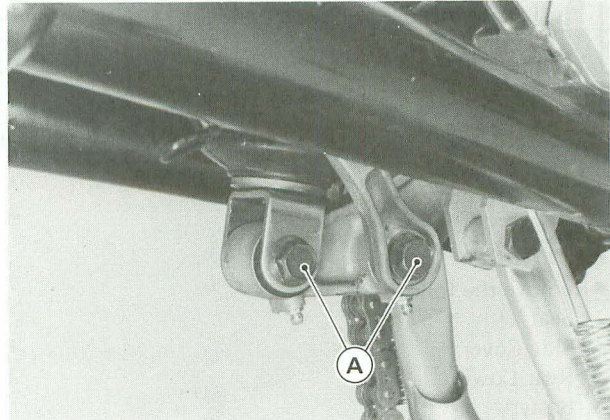

A. Bolts

- Remove the swing arm pivot shaft while supporting the swing arm.

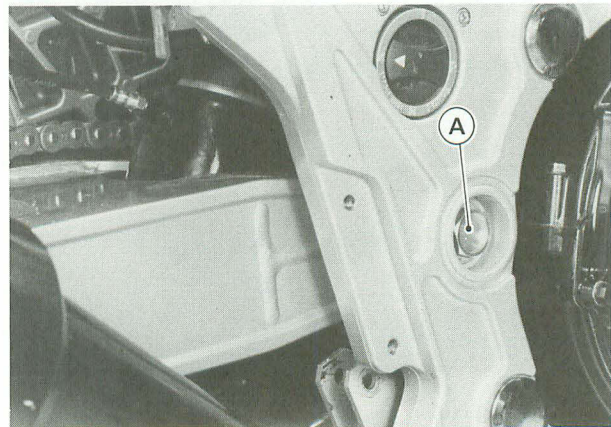

A. Pivot Shaft

- Remove the swing arm toward the rear.

Installation

- Installation is the reverse of removal. Note the following.
- Apply molybdenum disulfide grease to the inside of the needle bearings.
- Tighten the following nuts to the specified torque (see Exploded View).
 - Swing Arm Pivot Nut
 - Shock Absorber Nut
 - Tie-Rod Nut
 - Torque Link Nut
- Adjust the drive chain after installation (see Final Drive chapter).

Tie-Rod, Rocker Arm:

Tie-Rod Removal

- Remove the torque link from the caliper holder.
- Remove the tie-rod lower bolt.

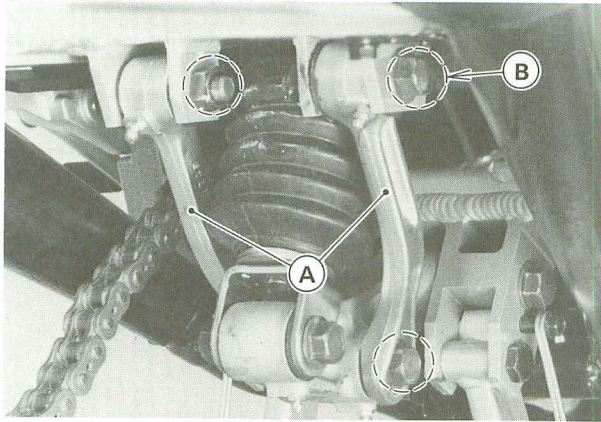

A. Tie Rods B. Bolts

- Remove the tie-rod upper bolts and take the tie-rod off.
- Remove the other tie-rod.

Tie-Rod Installation

- Apply molybdenum disulfide grease to the inside of the needle bearings.
- Tighten the tie-rod upper and lower bolts to the specified torque (see Exploded View).

Rocker Arm Removal

- Remove the following.
 - Fairings
 - Radiator
 - Muffler
- Remove the shock absorber bolt, tie-rod bolt, and rocker arm shaft.

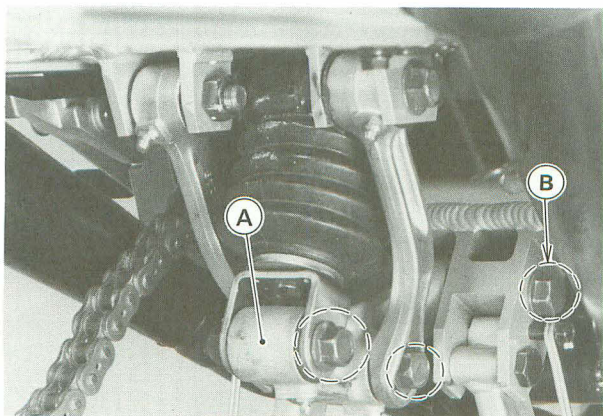

A. Rocker Arm B. Bolts

Rocker Arm Installation

- Installation is reverse of removal. Note the following.
- Apply molybdenum disulfide grease to the inside of the needle bearings.
- Tighten the following nut to the specified torque (see Exploded View).
 - Rocker Arm Nut
 - Shock Absorber Nut
 - Tie-Rod Nut

Needle Bearing Inspection

- ★ If there is any doubt as to the condition of either needle bearing, replace the bearing and sleeve as a set.

Tie-Rod, Rocker Arm Sleeve Inspection

- ★ If there is visible damage, replace the sleeve and needle bearing as a set.

Tie-Rod, Rocker Arm Needle Bearing Lubrication

There is a grease nipple on the tie-rod and rocker arm for lubrication.

- Force the molybdenum disulfide grease into the nipple until it comes out at both sides of the tie-rod or rocker arm, and wipe off any excess.

Steering

Table of Contents

Exploded View	13-2
Special Tools	13-3
Steering	13-4
Adjustment	13-4
Steering Stem	13-4
Removal	13-4
Installation	13-5
Steering Stem Bearing	13-6
Bearing Lubrication	13-6
Bearing Wear, Damage	13-6
Stem Cap Deterioration, Damage	13-6
Steering Stem Warp	13-6

13-2 STEERING

.....
Exploded View
.....

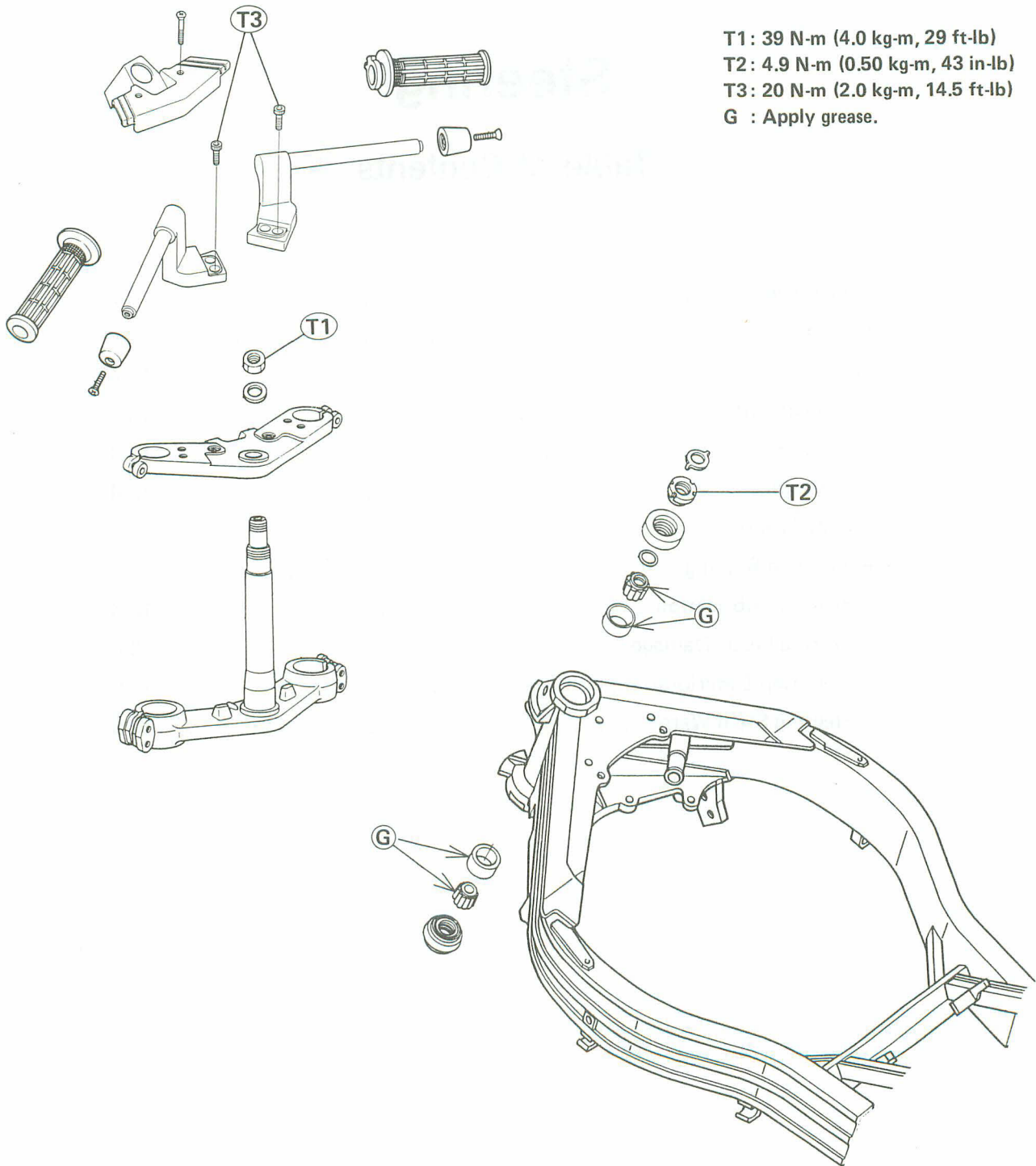

.....
Special Tools
.....

Stem Bearing Driver: 57001-137

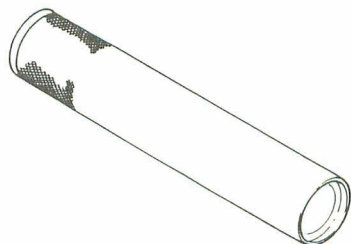

Adapter: 57001-1074



Bearing Puller: 57001-158

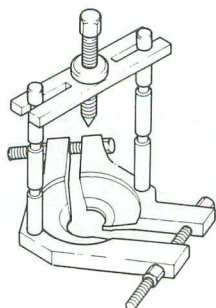

Adapter: 57001-317



Pole: 57001-1190

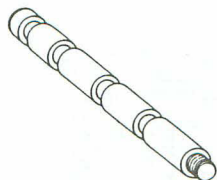

Stem Nut Wrench: 57001-1100

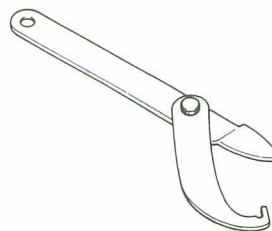

Stem Bearing Remover: 57001-1107

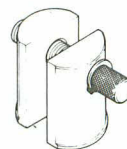

Driver Press Shaft: 57001-1075

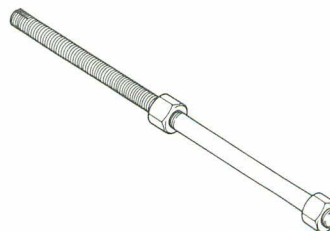

Driver: 57001-1106, 1076



Jack Stand: 57001-1238

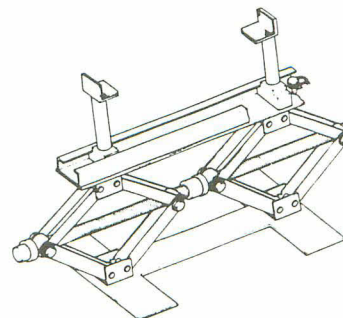

NOTE

○ The poles (P/N 57001-1190) are included in the bearing puller (P/N 57001-158).

13-4 STEERING

Steering

Adjustment

- Check the steering.
- Lift the front wheel off the ground using the jack stand (special tool: 57001-1238).
- With the front wheel pointing straight ahead, alternately tap each end of the handlebar. The front wheel should swing fully left and right from the force of gravity until the fork hits the stop.
- ★ If the wheel binds or catches before the stop, the steering is too tight.
- Feel for steering looseness by pushing and pulling the forks.
- ★ If you feel looseness, the steering is too loose.

NOTE

- *The cables and wiring will have some effect on the motion of the fork which must be taken into account. Be sure the wires and cables are properly routed.*
- *The bearings must be in good condition and properly lubricated in order for any test to be valid.*
- ★ Adjust the steering if necessary.
- Remove the following parts.
 - Fuel Tank
 - Fork Lower Clamp Bolts (both sides)
 - Stem Head Cover
 - Stem Head Nut (Loosen)
- Adjust the steering with the stem nut wrench (special tool).

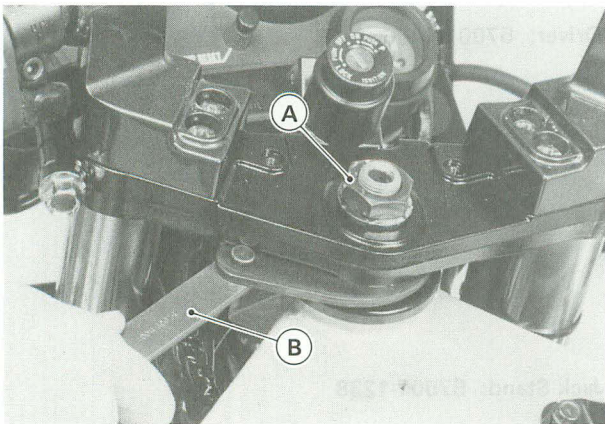

A. Stem Head Nut
B. Stem Nut Wrench: 57001-1100

- ★ If the steering is too tight, loosen the stem locknut a fraction of a turn.
- ★ If the steering is too loose, tighten the locknut a fraction of a turn.

NOTE

- *Turn the locknut 1/8 turn at a time maximum.*

- Tighten the following bolt and nut to the specified torque (see Exploded View).
 - Steering Stem Head Nut
 - Front Fork Clamp Bolt (see Suspension chapter)
- Check the steering again.
- ★ If the steering is still too tight or too loose, repeat the adjustment.

Steering Stem

Removal

- Remove the following parts.
 - Fuel Tank
 - Fairings
 - Handlebars
 - Front Wheel
 - Front Fork Legs
- Remove the brake hose joint from the stem base, and remove the front brake assembly as a set.

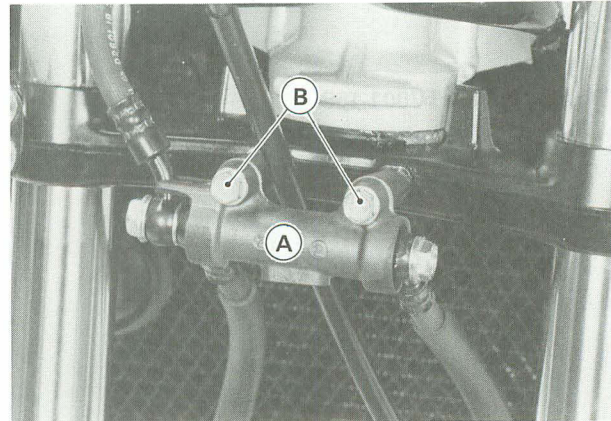

A. Brake Hose Joint B. Bolts

- Remove stem head nut and take off the steering stem head.
- Push up on the stem base, and remove the steering stem locknut using the stem nut wrench (special tool), then remove the steering stem base.

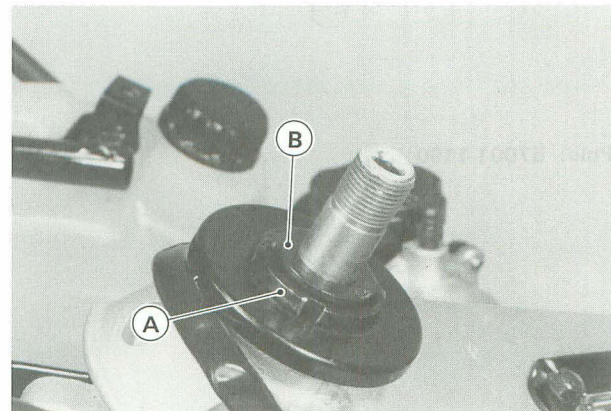

A. Stem Locknut B. Lockwasher

- Remove the upper tapered roller bearing inner race.
- To remove the outer races pressed into the head pipe, install the stem bearing remover (special tool) as shown below.

NOTE

○ If either steering stem bearing is damaged, it is recommended that both the upper and lower bearings (including outer races) should be replaced with new ones.

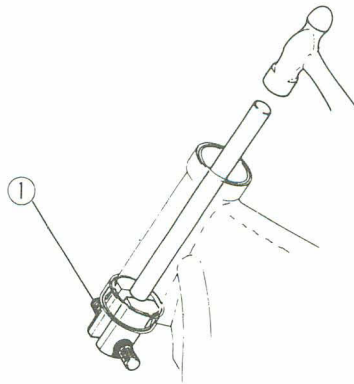

1. Stem Bearing Remover: 57001-1107

- Remove the lower tapered roller bearing (with its grease seal) which is pressed onto the steering stem, with the steering stem bearing puller and adapters (special tools).

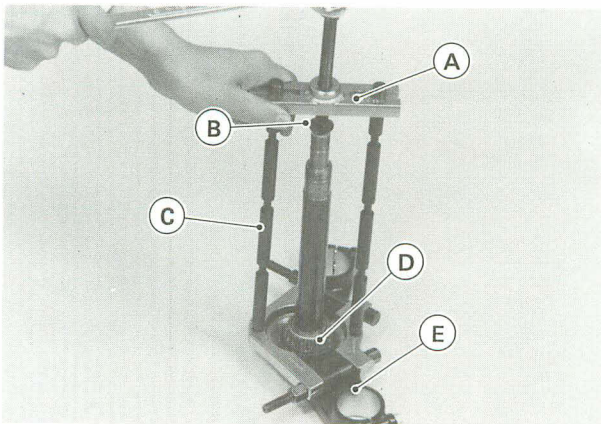

A. Bearing Puller: 57001-158
 B. Adapter: 57001-317
 C. Pole: 57001-1190
 D. Tapered Roller Bearing
 E. Stem Base

Installation

- Installation is the reverse of removal. Note the following.
- Apply grease to the outer races, and then drive them into the head pipe using the drivers and the driver press shaft (special tools).

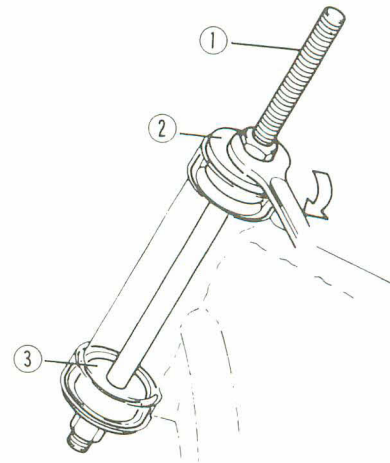

1. Driver Press Shaft: 57001-1075
 2. Driver: 57001-1106
 3. Driver: 57001-1076

- Apply grease to the lower tapered roller bearing, and drive it onto the steering stem using the stem bearing driver and adapter (special tools: 57001-137 and 57001-1074).

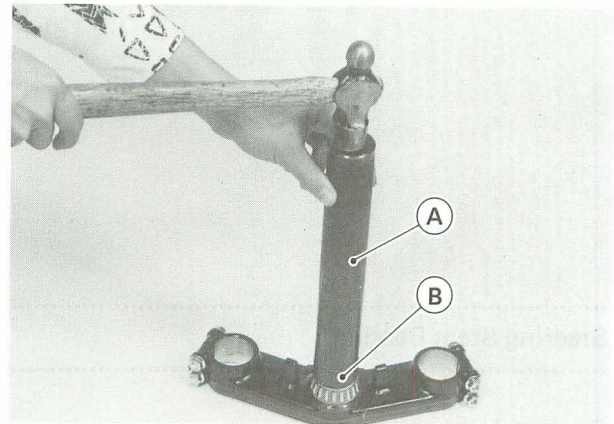

A. Stem Bearing Driver: 57001-137
 B. Adapter: 57001-1074

- The following four steps should be performed after steering bearing installation. This procedure settles the bearings in place.
- Using the stem nut wrench, tighten the stem locknut to 39 N-m (4.0 kg-m, 29 ft-lb) of torque. (To tighten the steering stem locknut to the specified torque, hook the wrench on the stem locknut, and pull the wrench at the hole by 22.2 kg force in the direction shown.)

13-6 STEERING

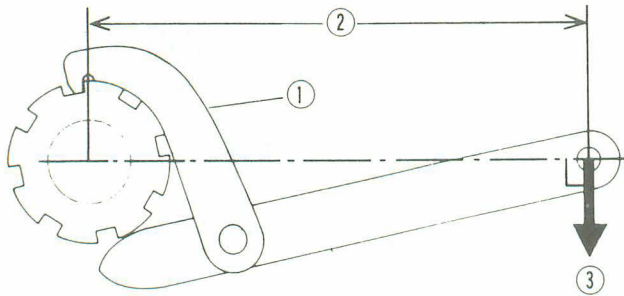

1. Stem Nut Wrench: 57001-1100 3. 22.2 kg
2. 180 mm

- Check that there is no play and the steering stem turns smoothly without the rattle.
- ☆ If not, the steering stem bearing may be damaged.
- Again back out the stem locknut a fraction of a turn until it turns lightly.
- Turn the stem locknut lightly clockwise until it just becomes hard to turn. Do not overtighten, or the steering will be too tight.
- Check and adjust the following items after installation.
 - Steering
 - Clutch
 - Throttle Cables
 - Choke Cable
 - Front Brake

Bearing Wear, Damage

- ★ Replace the bearing assemblies if they show damage.

Stem Cap Deterioration, Damage

- ★ Replace the grease seal if necessary.

Steering Stem Warp

- ★ If the steering stem shaft is bent, replace the steering stem.

Steering Stem Bearing

Bearing Lubrication

- Perform the following.
 - Remove the steering stem.
 - Using a high flash-point solvent, wash the upper and lower tapered roller bearings in the cages.
 - Wipe the upper and lower outer races, which are press-fitted into the frame head pipe, clean of grease and dirt.
 - Visually check the outer races and the rollers.
 - ☆ Replace the bearing assemblies if they show wear or damage.
 - Pack the upper and lower tapered roller bearings in the cages with grease, and apply light coat of grease to the upper and lower outer races.
 - Install the steering stem, and adjust the steering.

Frame

Table of Contents

Exploded View	14-2
Fairings	14-5
Fairing Removal	14-5
Inner Fairing Removal	14-6
Rear Cowl Removal	14-6
Fender	14-6
Rear Fender Removal	14-6

14-2 FRAME

Exploded View

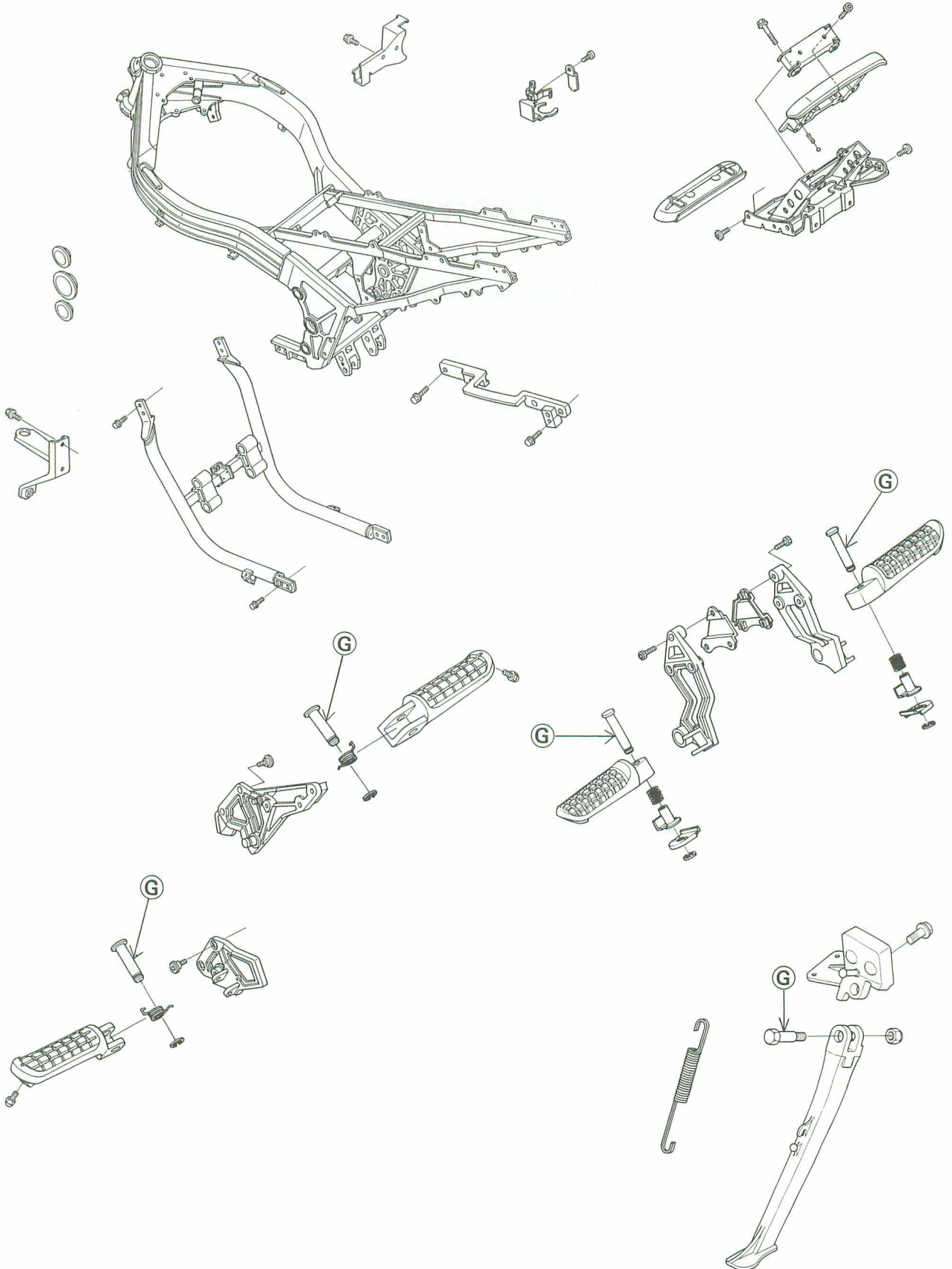

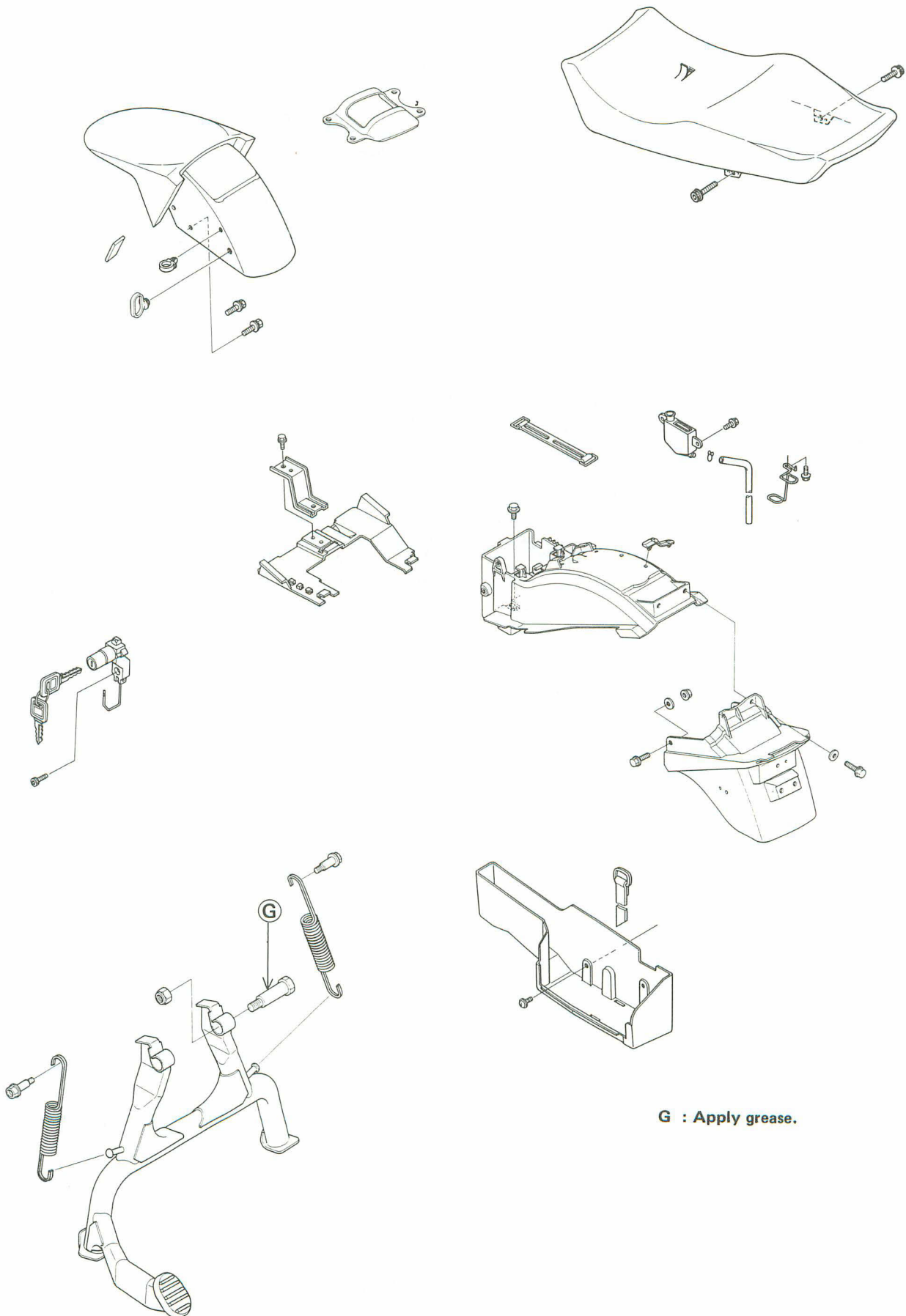

G : Apply grease.

14-4 FRAME

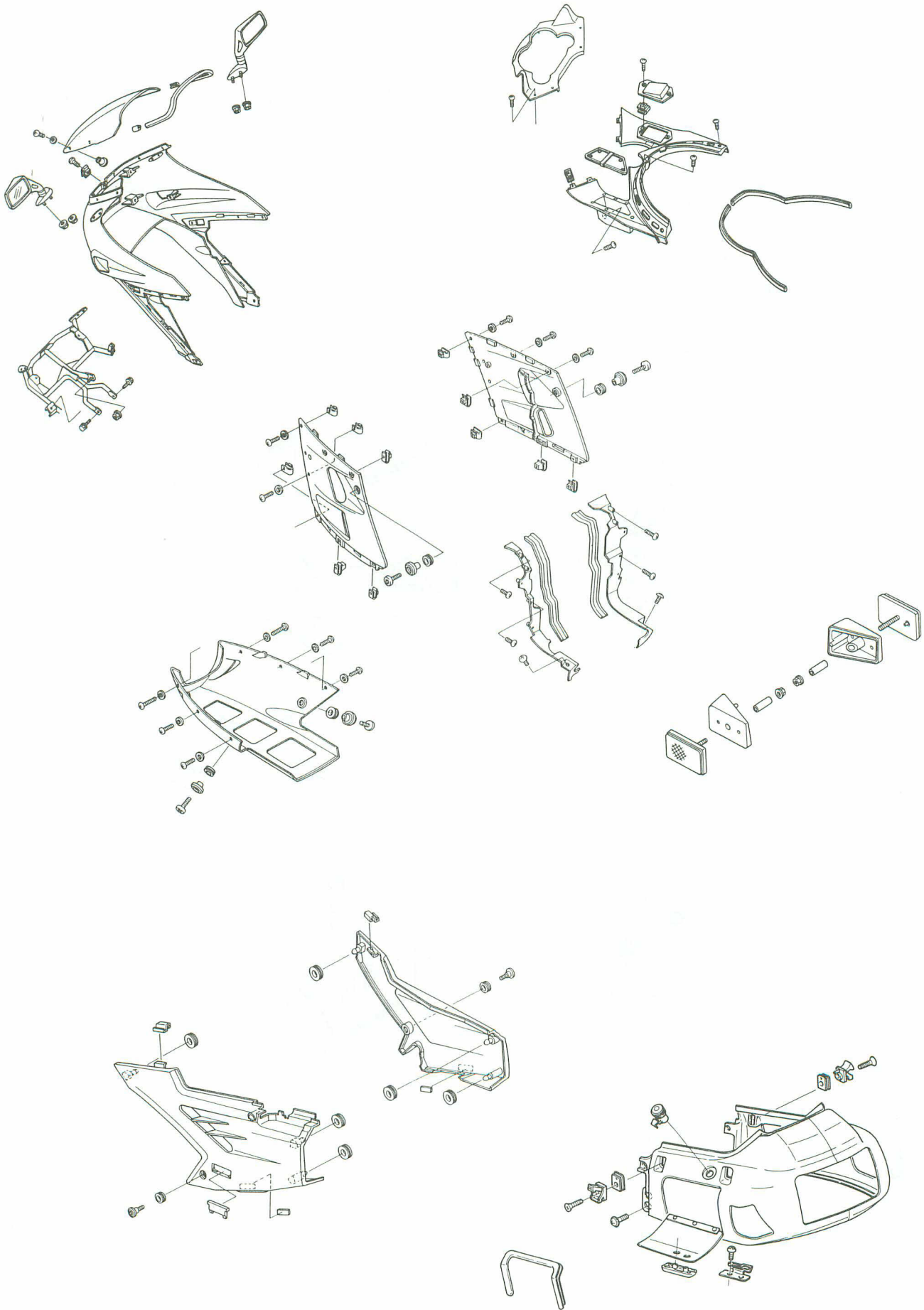

Fairings

Fairing Removal

- Remove the lower fairing.

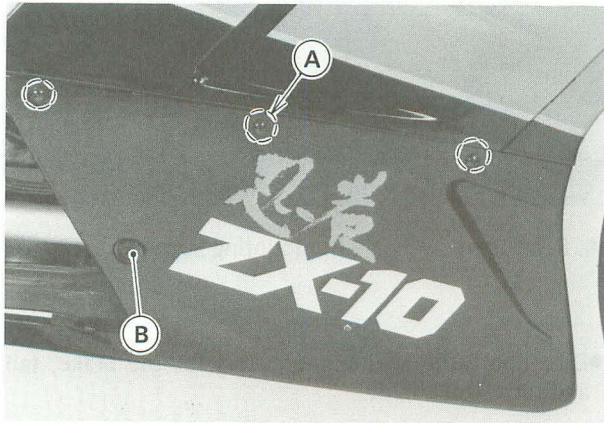

A. Screws B. Bolt

- Remove the side fairings.

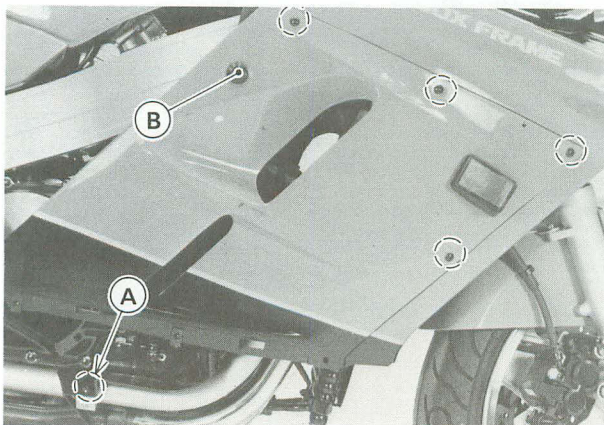

A. Screws B. Bolt

- Remove the upper fairing as follows.
- Remove the windshield.

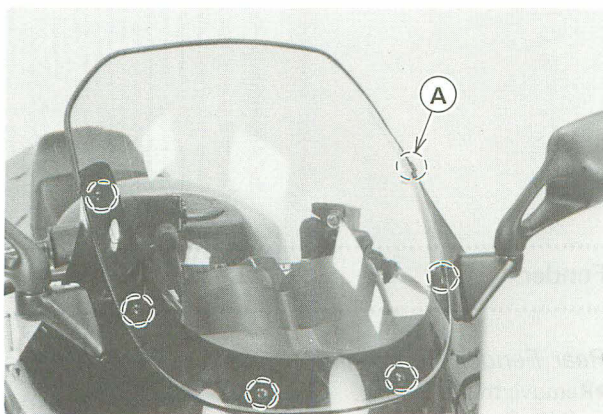

A. Screws

- Remove the front inner fairing.

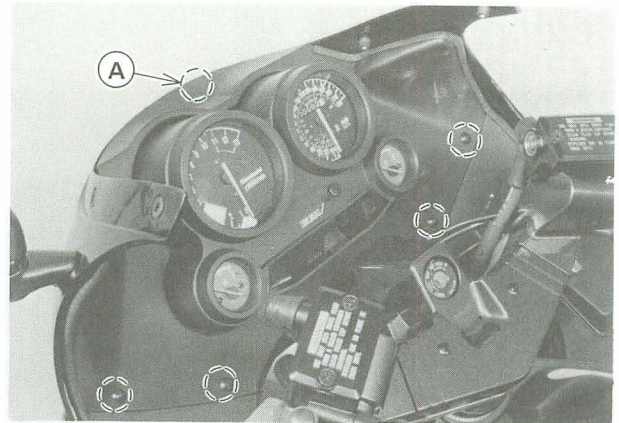

A. Screws

- Remove the rear view mirrors.

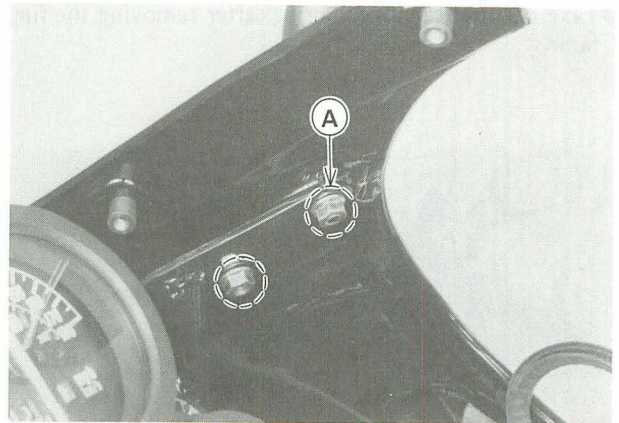

A. Mounting Nuts

- Disconnect the wiring connector.

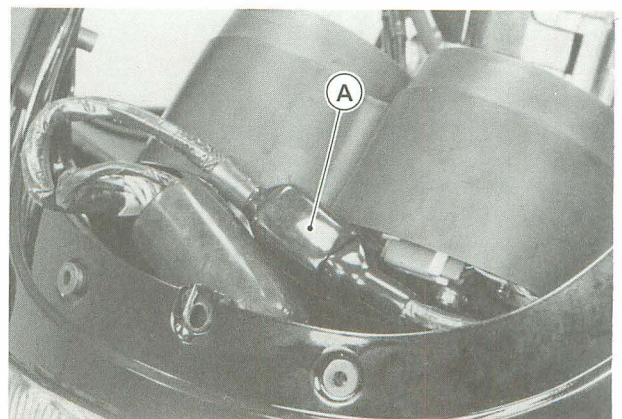

A. Connector

14-6 FRAME

Inner Fairing Removal

- Take off the front inner fairing, after remove the wind-shield.

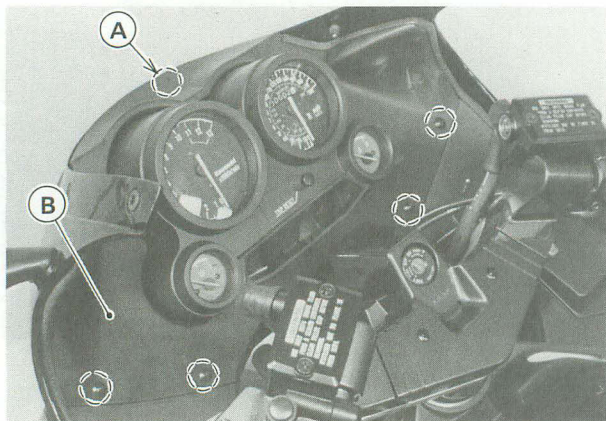

A. Screws

B. Front Inner Fairing

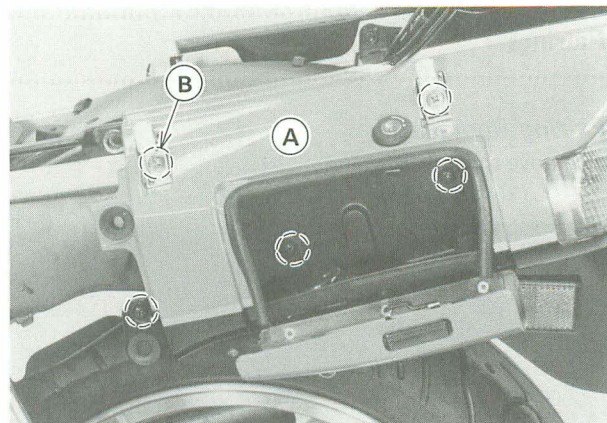

A. Rear Cowl

B. Mounting Screws

- Disconnect the wiring connectors for the brake, tail, and turn signal light.

- Take off the rear inner fairing, after removing the fuel tank.

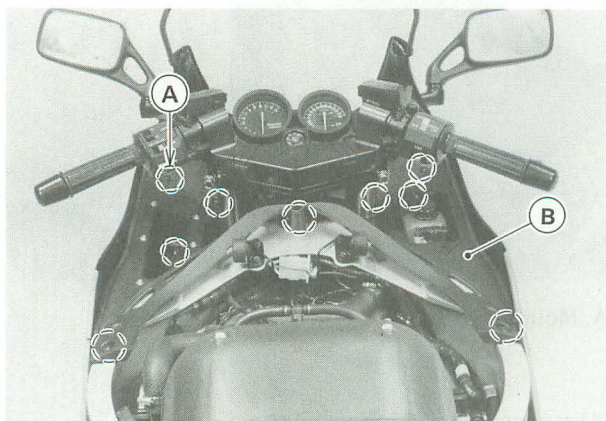

A. Screws

B. Rear Inner Fairing

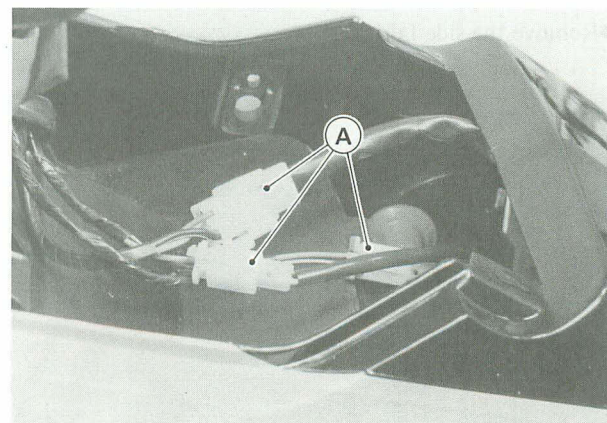

A. Connectors

Rear Cowl Removal

- Remove the following.
 - Seat
 - Side Cover
- Take off the rear cowl with the tool box toward the rear.

Fender

Rear Fender Removal

- Remove the following.
 - Rear Cowl
 - Rear Fender Rear Section

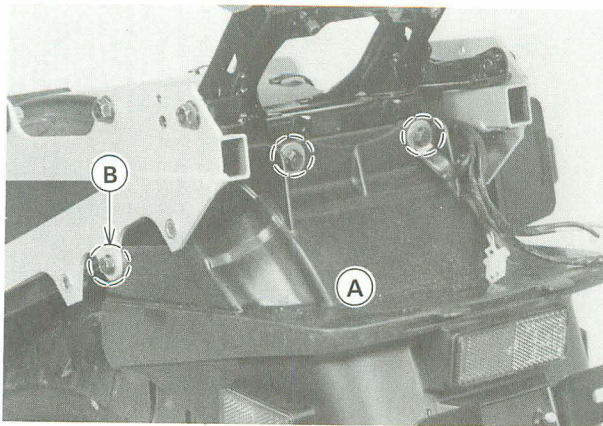

A. Rear Fender Rear Section B. Bolts

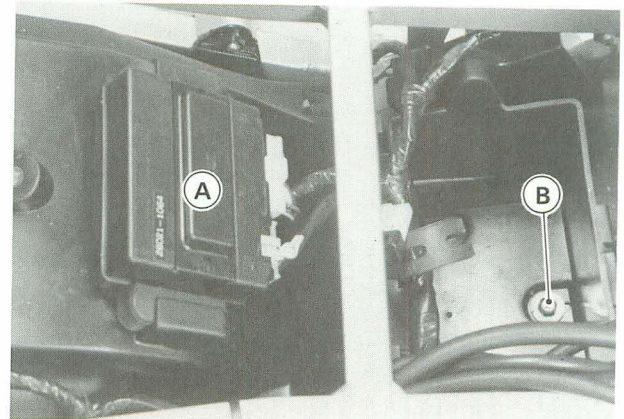

A. Junction Box B. Rear Fender Mounting Bolt

Battery
IC Igniter
Starter Relay
Reservoir Tank Mounting Bolt

●Take off the rear fender front section toward the rear.

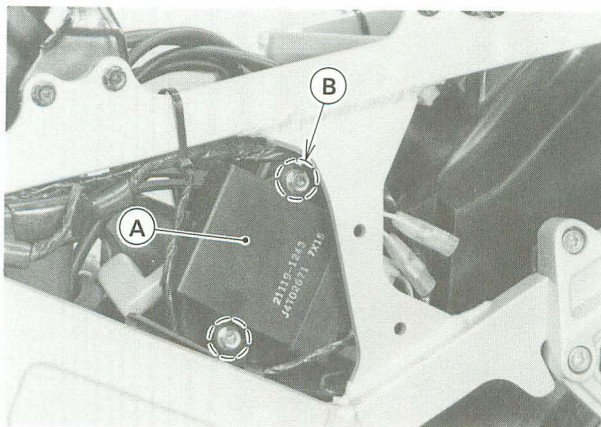

A. IC Igniter B. Bolts

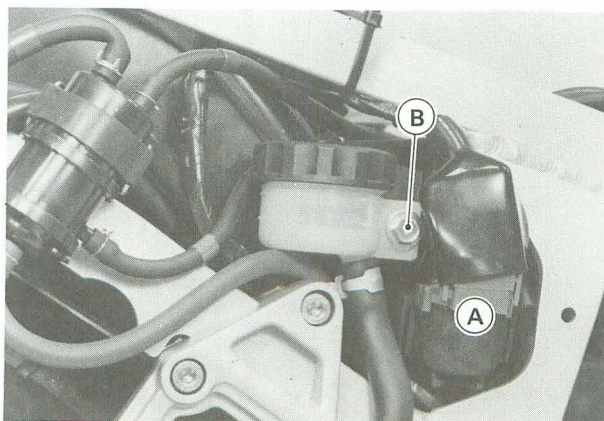

A. Starter Relay B. Reservoir Tank Mounting Bolt

Junction Box
Rear Fender Mounting Bolt

Electrical System

Table of Contents

Precautions	15-2	Headlight	15-28
Wiring Diagram (US and Canada)	15-3	Headlight Beam Horizontal	
Wiring Diagram (Other than US and Canada)	15-4	Adjustment	15-28
Parts Location	15-5	Headlight Beam Vertical	
Exploded View	15-6	Adjustment	15-28
Specifications	15-9	Headlight Circuit Inspection	
Special Tools	15-10	Headlight Reverse Lighting	
Battery	15-11	System Inspection	15-28
Electrolyte Level Inspection	15-11	Fuel Pump	15-30
Electrolyte Specific		Removal/Installation	15-30
Gravity Inspection	15-11	Inspection	15-30
Initial Charging	15-11	Cooling Fan System	15-31
Ordinary Charging	15-12	Fan System Circuit Inspection	15-31
Alternator	15-12	Fan Inspection	15-31
Removal	15-12	Fan Switch Inspection	15-31
Installation	15-13	Meters, Gauges	15-32
Disassembly	15-13	Tachometer Removal	15-32
Assembly	15-14	Tachometer Inspection	15-32
Stator Coil Inspection	15-14	Fuel Gauge Operation Inspection	15-33
Rotor Coil Inspection	15-15	Fuel Level Sensor Inspection	15-33
Slip Ring Cleaning	15-15	Water Temperature Gauge	
Slip Ring Diameter	15-15	Operation Inspection	15-34
Carbon Brush Length	15-15	Water Temperature Sensor	
Rectifier Inspection	15-15	Inspection	15-35
Regulator Inspection	15-16	Junction Box	15-36
Alternator Troubleshooting	15-16	Fuse Removal	15-36
Test No.1-Battery Discharged	15-17	Fuse Installation	15-36
Test No.2-Battery Overcharged	15-17	Fuse Inspection	15-36
Test No.3-Noise	15-17	Junction Box Fuse Circuit	
Ignition System	15-18	Inspection	15-36
Pickup Coil Removal	15-18	Starter Circuit and	
Pickup Coil Installation	15-18	and Headlight Relay Inspection	15-37
Pickup Coil Inspection	15-18	Diode Circuit Inspection	15-37
Ignition Coil Removal/Installation	15-19		
Ignition Coil Inspection	15-19		
Spark Plug Gap	15-20		
IC Igniter Inspection	15-20		
Electric Starter System	15-23		
Starter Motor Removal	15-23		
Starter Motor Installation	15-23		
Starter Motor Disassembly	15-23		
Starter Motor Assembly	15-24		
Brush Inspection	15-25		
Commutator Cleaning and			
Inspection	15-25		
Armature Inspection	15-25		
Negative Brush and			
Lead Assembly Inspection	15-25		
Brush Plate Inspection	15-25		
Starter Relay Inspection	15-26		

15-2 ELECTRICAL SYSTEM

Precautions

There are a number of important precautions that are musts when servicing electrical systems. Learn and observe all the rules below.

- Do not reverse the battery lead connections. This will burn out the diodes in the electrical parts.
- Always check battery condition before condemning other parts of an electrical system. A fully charged battery is a must for conducting accurate electrical system tests.
- The electrical parts should never be struck sharply, as with a hammer, or allowed to fall on a hard surface. Such a shock to the parts can damage them.
- To prevent damage to electrical parts, do not disconnect the battery leads or any other electrical connections when the ignition switch is on, or the engine is running.
- Because of the large amount of current, never keep the starter switch pushed when the starter motor will not turn over, or the current may burn out the starter motor windings.
- Do not use a meter illumination bulb rated for other than voltage or wattage specified in the wiring diagram, as the meter or gauge panel could be warped by excessive heat radiated from the bulb.
- Take care not to short the leads that are directly connected to the battery positive (+) terminal to the chassis ground.
- Troubles may involve one or in some cases all items. Never replace a defective part without determining what CAUSED the failure. If the failure was caused by some other item or items, they too must be repaired or replaced, or the new replacement will soon fail again.
- Make sure all connectors in the circuit are clean and tight, and examine wires for signs of burning, fraying, etc. Poor wires and bad connections will affect electrical system operation.
- Measure coil and winding resistance when the part is cold (at room temperature).

○Electrical Connectors

Male Connectors

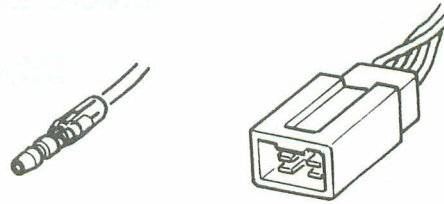

Color Codes:

BK	Black
BL	Blue
BR	Brown
CH	Chocolate
DG	Dark green
G	Green
GY	Gray
LB	Light blue
LG	Light green
O	Orange
P	Pink
PU	Purple
R	Red
W	White
Y	Yellow

Female Connectors

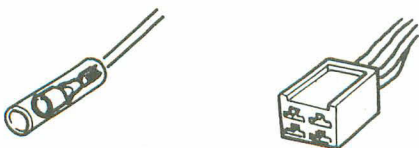

15-4 ELECTRICAL SYSTEM

ZX1000-B1/B2/B3 Wiring Diagram (Other than US and Canada)

1. Headlight Switch
2. Front Brake Light Switch
3. Engine Stop Switch
4. Starter Button

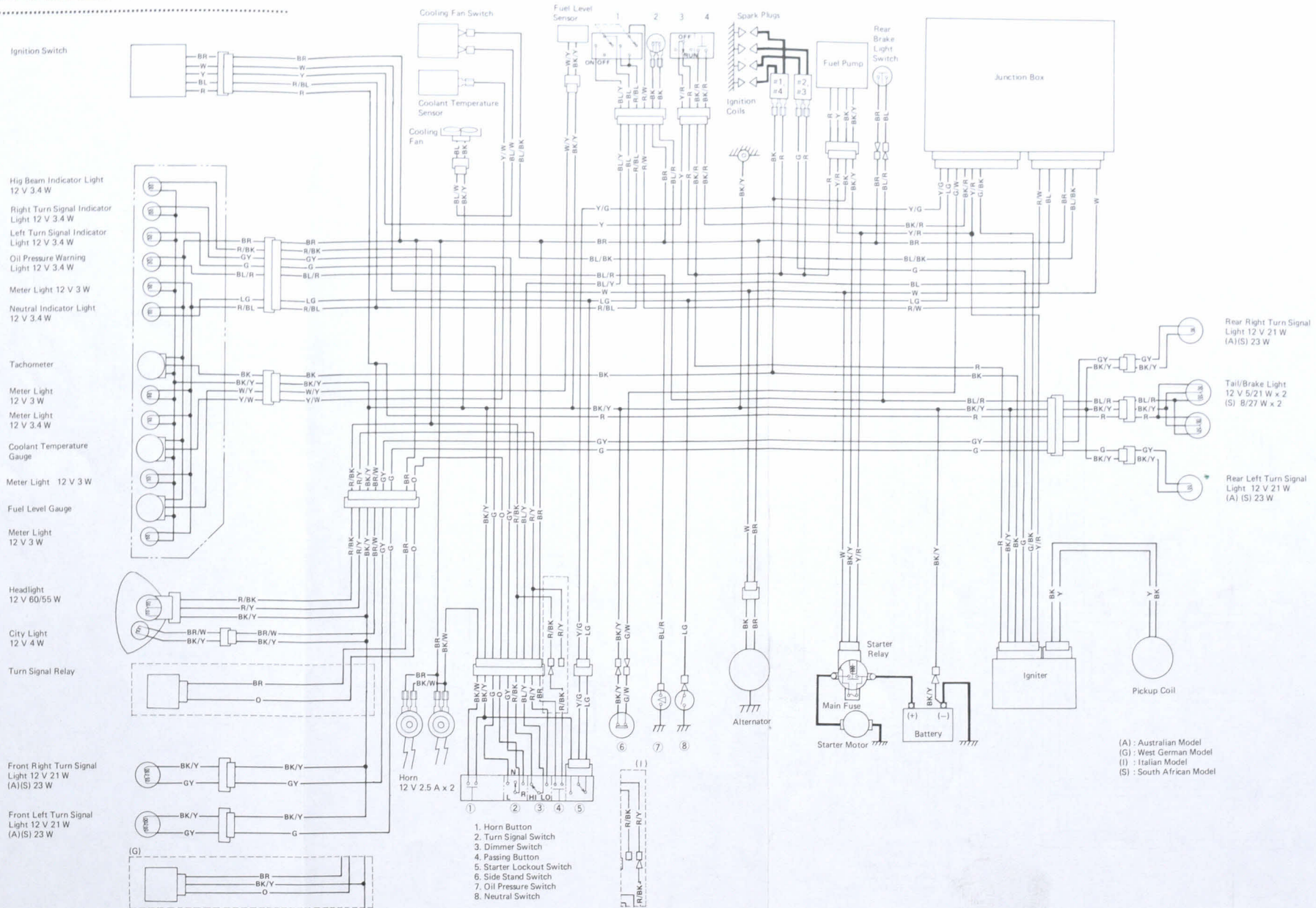

Color Code	
BK	Black
BL	Blue
BR	Brown
CH	Chocolate
DG	Dark green
G	Green
GY	Gray
LB	Light blue
LG	Light green
O	Orange
P	Pink
PU	Purple
R	Red
W	White
Y	Yellow

(A) : Australian Model
(G) : West German Model
(I) : Italian Model
(S) : South African Model

1. Horn Button
2. Turn Signal Switch
3. Dimmer Switch
4. Passing Button
5. Starter Lockout Switch
6. Side Stand Switch
7. Oil Pressure Switch
8. Neutral Switch

LEFT HANDLEBAR SWITCH CONNECTIONS															
Starter Lockout Switch			Horn Button			Dimmer Switch			Turn Signal Switch			Passing Button			
Color	BK/Y	Y/G	LG	Color	BK/Y	BK/W	Color	R/BK	BL/Y	R/Y	Color	R	Color	R/BK	BR
Released	○	○	○	ON (Push)	○	○	HI	○	○	○	Color	R	ON (Push)	○	○
Pulled in	○	○	○				LO	○	○	○	Color	N			
								○	○	○	Color	L			

IGNITION SWITCH CONNECTIONS					
Color	Light	Battery	Ignition	Tail 1	Tail 2
OFF, LOCK	BR	W	Y	BL	R
ON	○	○	○	○	○
P (PARK)	○	○	○	○	○

RIGHT HANDLEBAR SWITCH CONNECTIONS													
Engine Stop Switch			Headlight Switch				Starter Button		Front Brake Light Switch				
Color	Y/R	R	Color	R/W	R/BL	BL	BL/Y	Color	BK/R	BK/R	Color	BK	BK
OFF			OFF	○	○	○	○	Push	○	○	Released		
				○	○	○	○						
RUN	○	○	ON	○	○	○	○				Pulled in	○	○

Parts Location

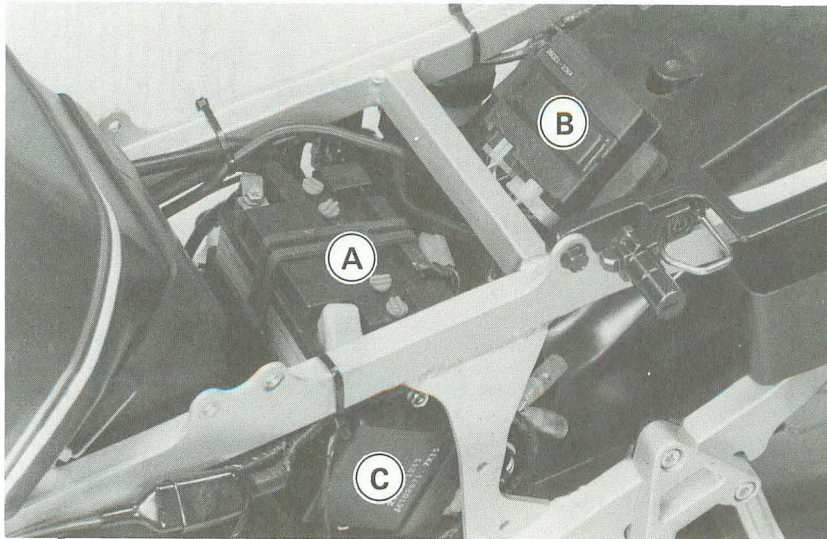

- A. Battery
- B. Junction Box
- C. IC Igniter

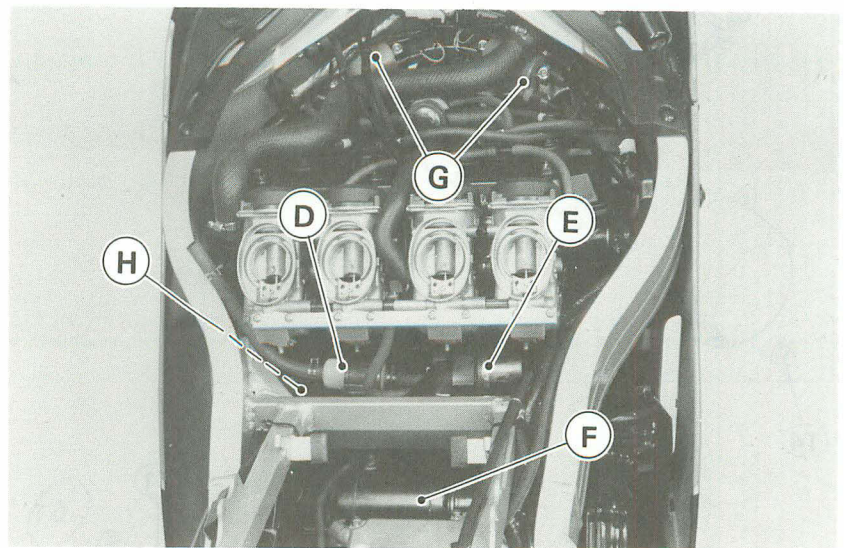

- D. Fuel Filter
- E. Fuel Pump
- F. Starter Motor
- G. Ignition Coil
- H. Alternator

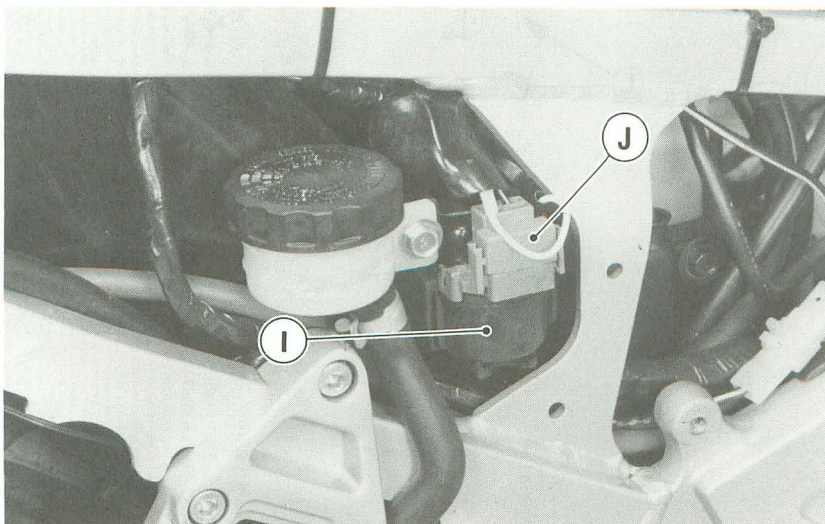

- I. Starter Relay
- J. Main Fuse 30A

15-6 ELECTRICAL SYSTEM

Exploded View

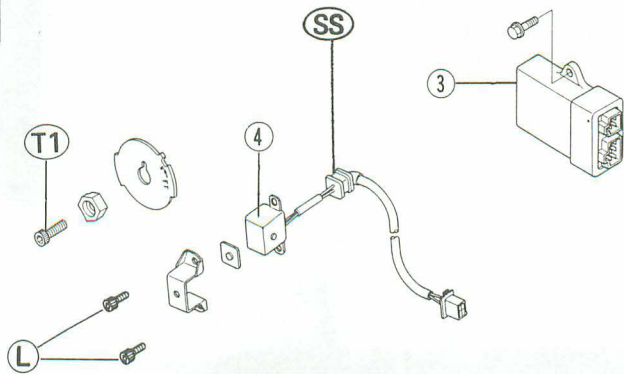
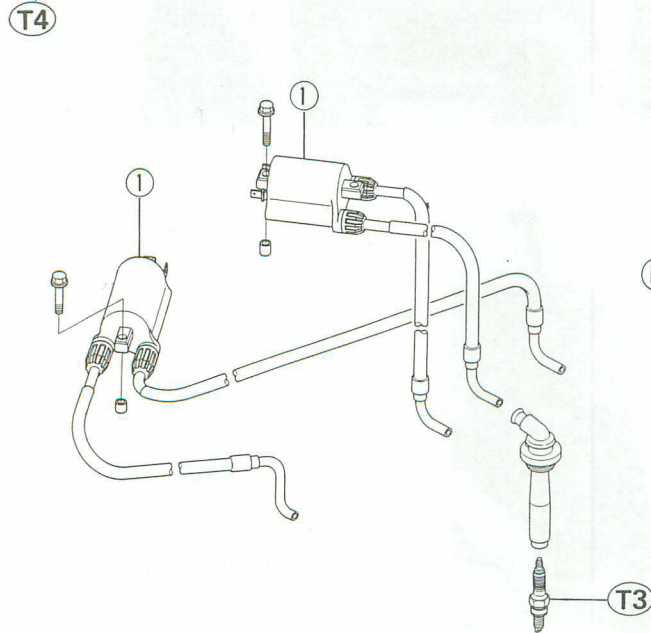
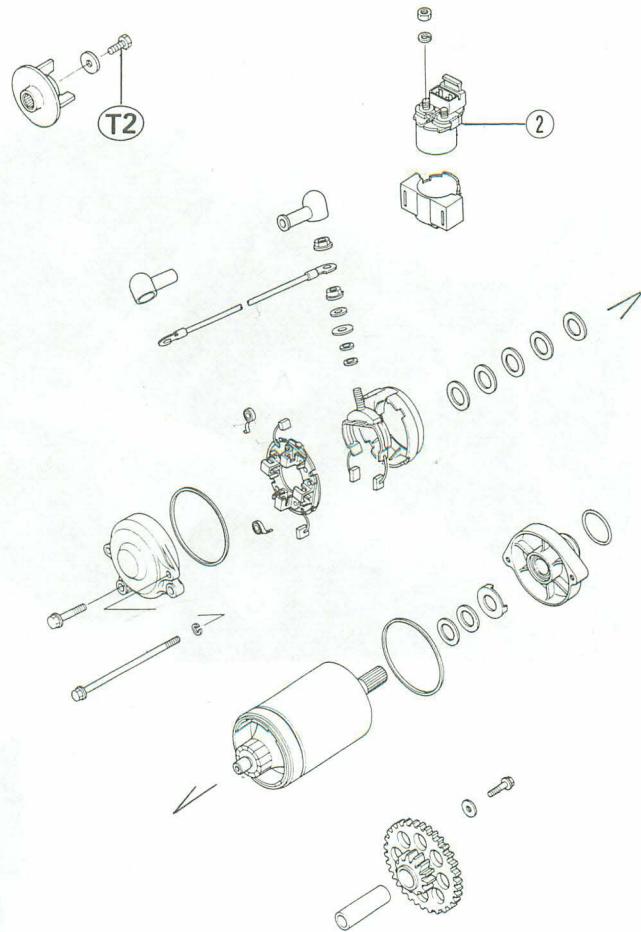
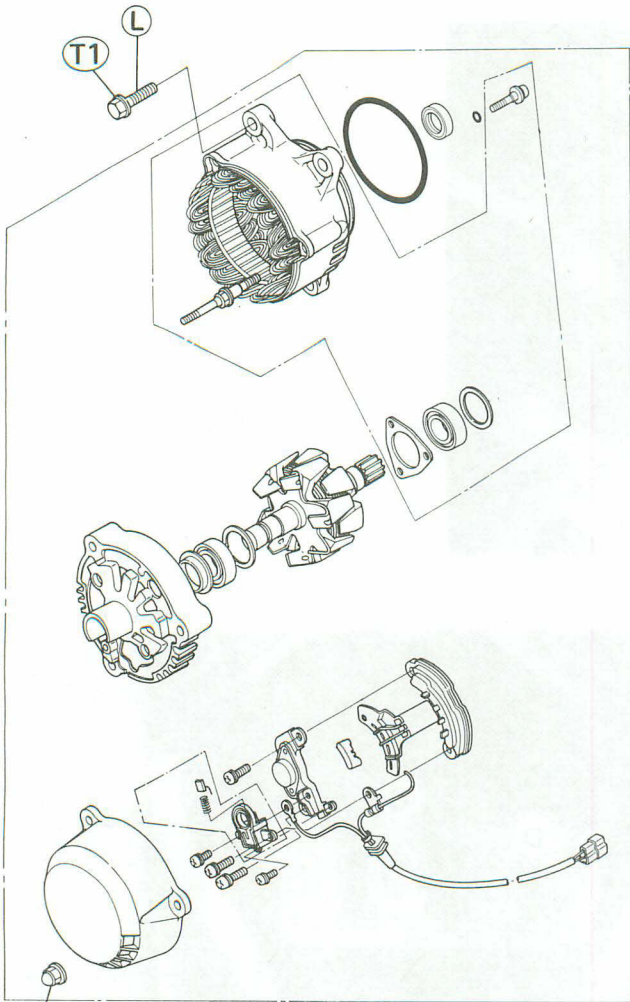

- 1. Ignition Coils
- 2. Starter Relay
- 3. IC Igniter
- 4. Pickup Coil

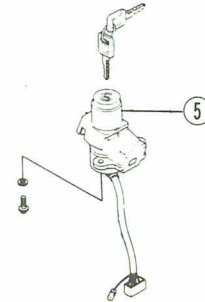
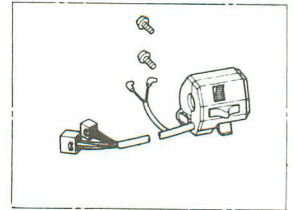
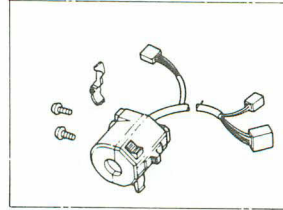
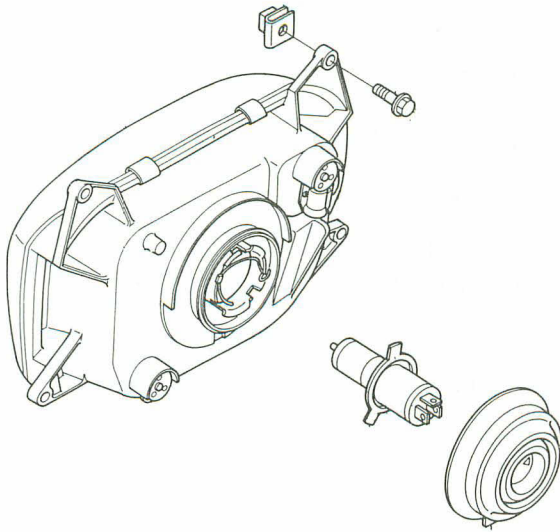

Frame No.
JKAZXCB1□JA004564 ~
ZXT00B-004564 ~

5. Ignition Switch

T1: 25 N-m (2.5 kg-m, 18.0 ft-lb)

T2: 9.8 N-m (1.0 kg-m, 87 in-lb)

T3: 14 N-m (1.4 kg-m, 10.0 ft-lb)

T4: 4.9 N-m (0.50 kg-m, 43 in-lb)

L : Apply a non-permanent locking agent

SS : Apply silicone sealant.

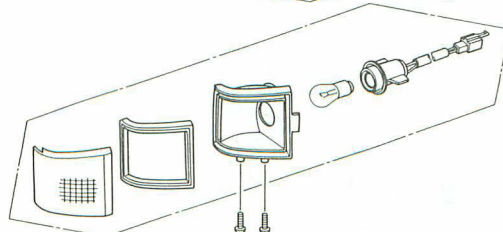
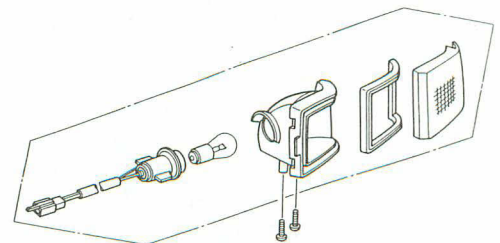
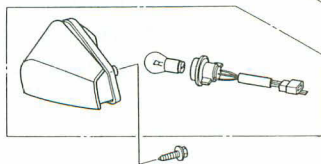
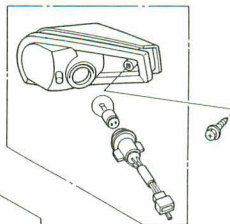
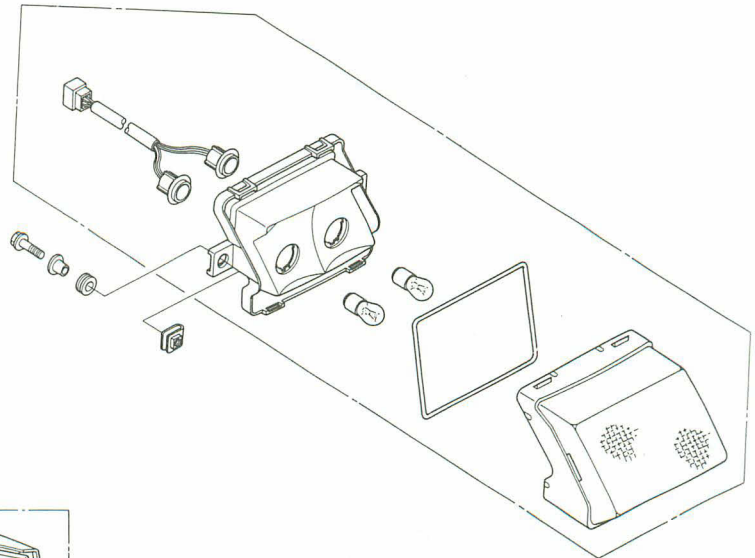

15-8 ELECTRICAL SYSTEM

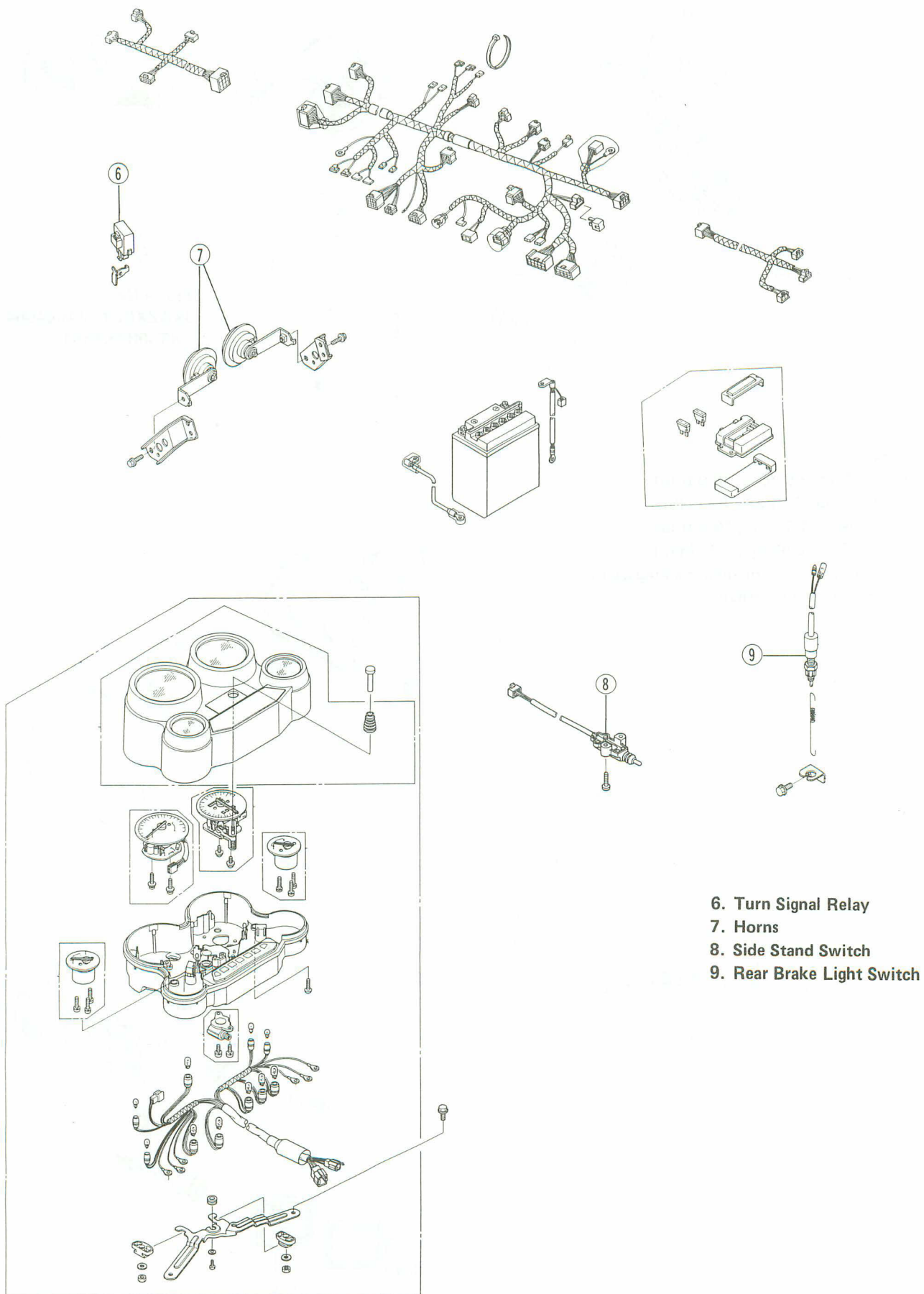

- 6. Turn Signal Relay
- 7. Horns
- 8. Side Stand Switch
- 9. Rear Brake Light Switch

.....
Specifications

Item	Standard	Service Limit
Battery:		
Type	12 V 14 Ah	---
Specific gravity	1.280 @20°C (68°F)	---
Alternator:		
Charging voltage	14.5 V Night @4 000 r/min (rpm)	---
Rotor coil resistance	About 4 Ω (ZX1000-B1), About 6 Ω	---
Stator coil resistance	Less than 1.0 Ω	---
Slip ring diameter	14.4 mm	14.0 mm
Carbon brush length	10.5 mm	4.5 mm
Ignition System:		
Pickup coil air gap	0.7 mm	---
Pickup coil resistance	400 – 490 Ω	---
Ignition coil:		
3 needle arcing distance	6 mm or more	---
Primary winding resistance	2.6 – 3.2 Ω	---
Secondary winding resistance	13 – 17 k Ω	---
Spark plug gap	0.7 – 0.8 mm	---
Starter Motor:		
Carbon brush length	12 mm	8.5 mm
Commutator groove depth	0.7 mm	0.2 mm
Commutator diameter	28 mm	27 mm
Switches and Sensors:		
Rear brake light switch	ON after about 10 mm pedal travel	---
Fan switch: OFF \rightarrow ON	96 – 100°C (205 – 212°F)	---
ON \rightarrow OFF	91 – 95°C (196 – 203°F)	---
Water temperature sensor resistance	80°C (176°F) : about 52 Ω	---
	100°C (212°F): about 27 Ω	---
Fuel level sensor resistance	Full position 4 – 10 Ω	---
	Empty position 90 – 100 Ω	---

Spark Plug

	Standard
US, Australia, Italy, South Africa	NGK C9E ND U27ES-N
Other	NGK CR9E ND U27ESR-N

15-10 ELECTRICAL SYSTEM

.....
Special Tools
.....

Ignition Coil Tester: 57001-1242

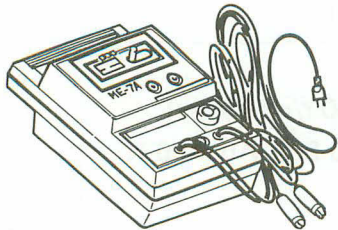

Hand Tester: 57001-983

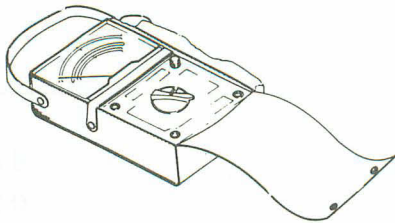

Spark Plug Wrench: 57001-1262

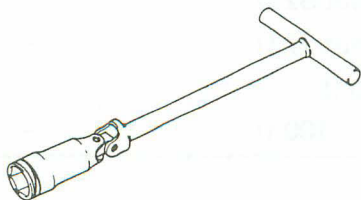

Battery

Electrolyte Level Inspection

- The electrolyte level should be between the upper and the lower level lines.
- ★ If the level of electrolyte in any cell is below the lower level line, add only distilled water to cell, until the level is at the upper level line.

CAUTION

- Ordinary tap water is not a substitute for distilled water and will shorten the life of the battery.

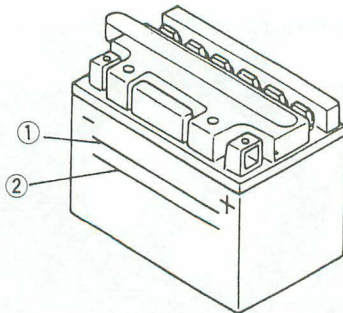

1. Upper Level Line 2. Lower Level Line

Electrolyte Specific Gravity Inspection

- Check battery condition by testing the specific gravity of the electrolyte in each cell with a hydrometer.
- Read the level of the electrolyte on the floating scale.

Hydrometer

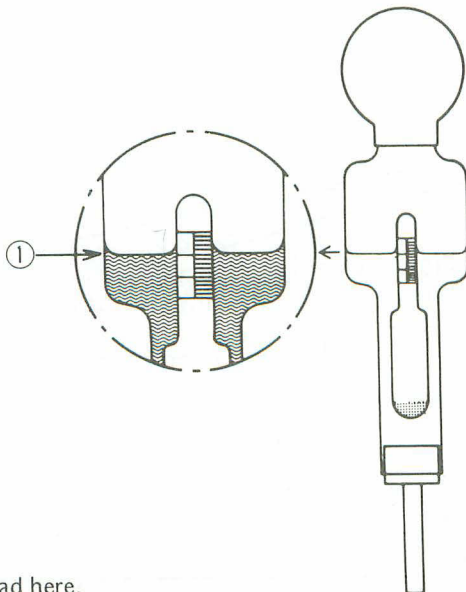

1. Read here.

- ★ If the specific gravity is below 1.20 (charge 60%) the battery needs to be charged.

Initial Charging

WARNING

- Keep the battery away from sparks and open flames during charging, since the battery gives off an explosive gas mixture of hydrogen and oxygen. When using a battery charger, connect the battery to the charger before turning on the charger. This procedure prevents sparks at the battery terminals which could ignite any battery gases.

- Fill each cell to the upper level line on the battery case with fresh electrolyte (special gravity: 1.280) at a temperature of 30°C (86°F) or less. Let the battery stand for about 30 minutes before charging.

NOTE

- If the electrolyte level drops, add electrolyte to the upper level line before charging.

- Set the charging rate at 1/10 the battery capacity, and charge it for 10 hours. For example, if the battery is rated at 14 Ah, the charging rate would be 1.4 A.

CAUTION

- If the battery is not given a full initial charging, it will discharge in a few weeks. After that it can not be charged by supplement charging.
- Do not use a high rate battery charger, as is typically employed at automotive service stations, unless the charger rate can be reduced to the level required. Charging the battery at a rate higher than specified may ruin the battery. Charging at a high rate causes excess heat which can warp the plates and cause internal shorting. Higher-than-normal charging rates also cause the plates to shed active material. Deposits will accumulate, and can cause internal shorting.
- If the temperature of the electrolyte rises above 45°C (115°F) during charging, reduce the charging rate to lower the temperature, and increase charging time proportionately.

15-12 ELECTRICAL SYSTEM

Ordinary Charging

WARNING

- Keep the battery away from sparks and open flames during charging, since the battery gives off an explosive gas mixture of hydrogen and oxygen. When using a battery charger, connect the battery to the charger before turning on the charger. This procedure prevents sparks at the battery terminals which could ignite any battery gases.

CAUTION

- Always remove the battery from the motorcycle for charging. If the battery is charged while still installed, battery electrolyte may spill and corrode the frame or other parts of the motorcycle.

CAUTION

- Do not use a high rate battery charger, as is typically employed at automotive service stations, unless the charger rate can be reduced to the level required. Charging the battery at a rate higher than specified may ruin the battery. Charging at a high rate causes excess heat which can warp the plates and cause internal shorting. Higher-than-normal charging rates also cause the plates to shed active material. Deposits will accumulate, and can cause internal shorting.
- If the temperature of the electrolyte rises above 45°C (115°F) during charging, reduce the charging rate to lower the temperature, and increase charging time proportionately.
- Check the electrolyte level after charging.

Alternator

Removal

NOTE

- Alternator removal is not necessary to remove the rectifier, regulator, and carbon brush assembly. They can be removed often removing the alternator end cover.

- Remove the following.
 - Fairings
 - Alternator Lead Connector
 - Alternator Mounting Bolts

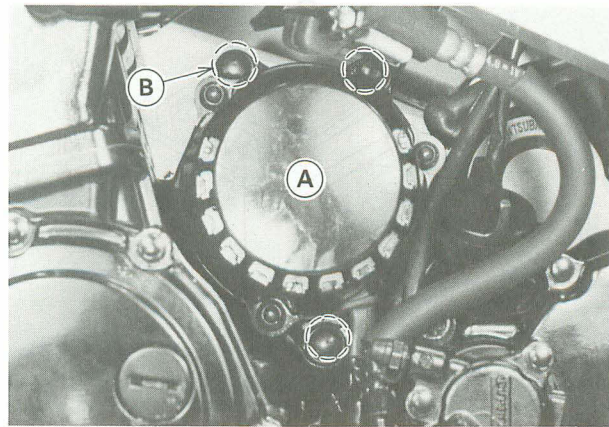

A. Alternator

B. Mounting Bolts

- Pull out the alternator.

Battery Charging Rate/Time Table (12V 14Ah)

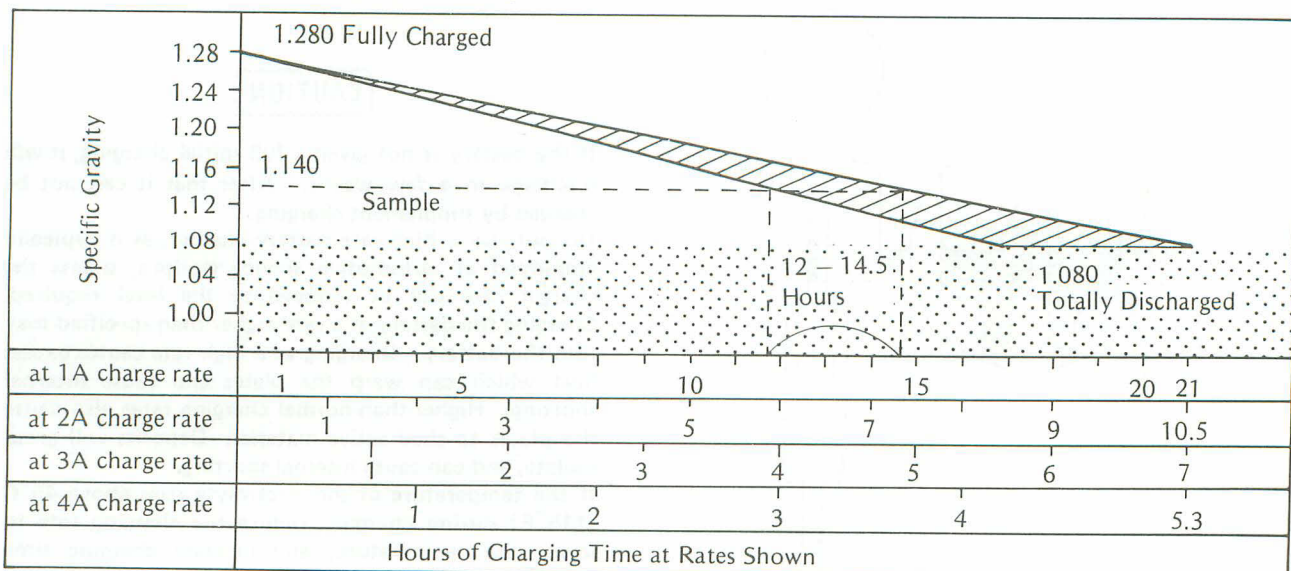

Installation

- Clean the alternator legs and crankcase where the alternator is grounded.
- Apply a small amount of engine oil to the rubber dampers and the O-ring.

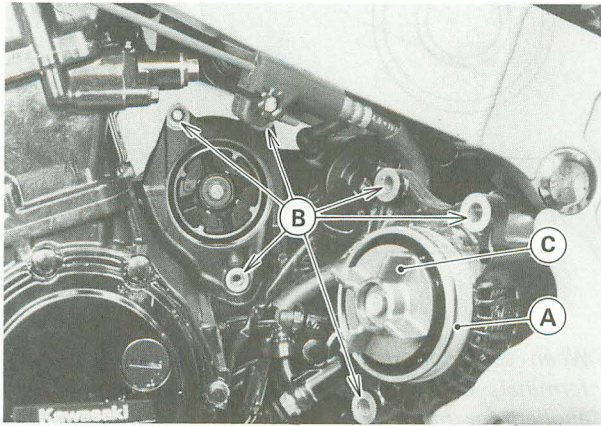

A. O-ring C. Coupling Blades
B. Clean here.

- Apply non-permanent locking agent to the alternator mounting bolts, and tighten them to the specified torque (see Exploded View).

CAUTION

ⓘ If any resistance is felt when tightening the mounting bolts, stop immediately, and check the alignment of the coupling blades with the slots in the rubber dampers.

Disassembly

- Remove the following.
 - End Cover
 - Brush Assembly
 - Rectifier
 - Regulator
- Unsolder the wires on the rectifier.

NOTE

ⓘ When unsoldering the alternator wires to the rectifier terminal, do it quickly. If high temperatures are applied for more than a few seconds, the rectifier's diodes may be damaged.

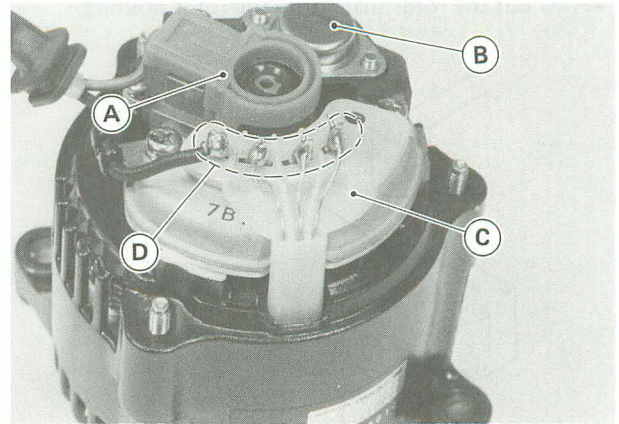

A. Brush Assembly C. Rectifier
B. Regulator D. Unsolder

- Remove the alternator coupling.

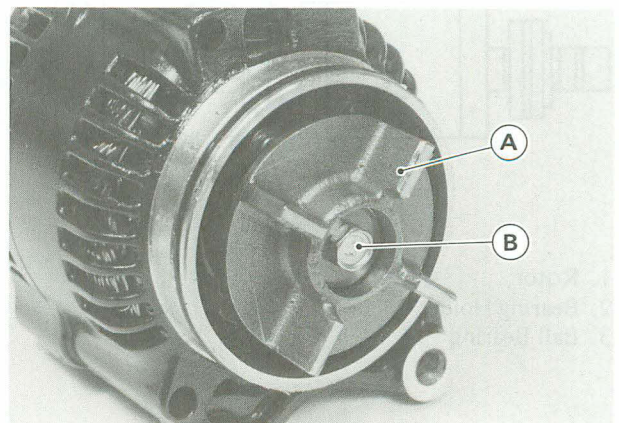

A. Alternator Coupling B. Mounting Bolt

- Remove the stator housing.

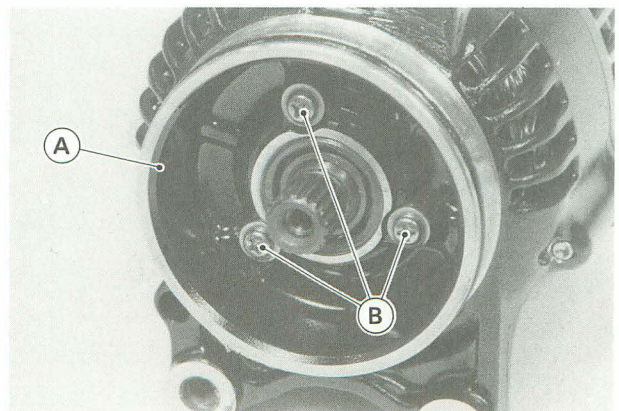

A. Stator Housing B. Screws

15-14 ELECTRICAL SYSTEM

- Press out the rotor shaft from the rotor housing.

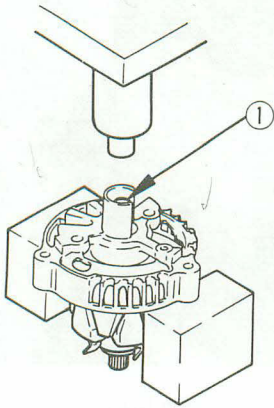

1. Rotor Shaft

- To remove the ball bearings, use a suitable puller.

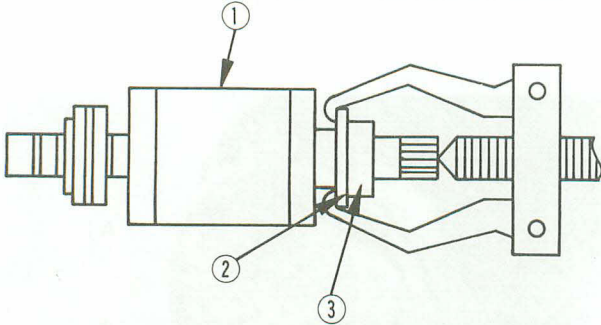

1. Rotor
2. Bearing Holder
3. Ball Bearing

Assembly

- Assembly is the reverse of disassembly. Note the following.
- When installing the rotor bearing, press the bearing and bearing covers onto the rotor shaft. The bearing short end from the bearing ring must face in.

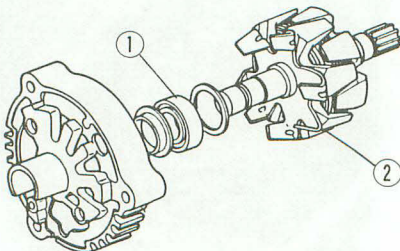

1. Rotor Bearing
2. Rotor

- Position the rotor bearing ring so that the projections of it are aligned with the ring positioning groove.

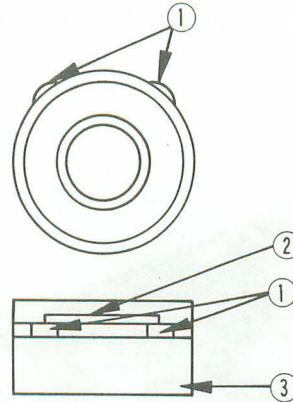

1. Projections of Ring
2. Ring Groove
3. Rotor Bearing

NOTE

○ When soldering the alternator wires to the rectifier terminal, do it quickly. If high temperatures are applied for more than a few seconds, the rectifier's diodes may be damaged.

- Tighten the pulley nut to the specified torque (see Exploded View).

Stator Coil Inspection

- Connect an ohmmeter (x 1 Ω range) between the coil wires and read the meter.

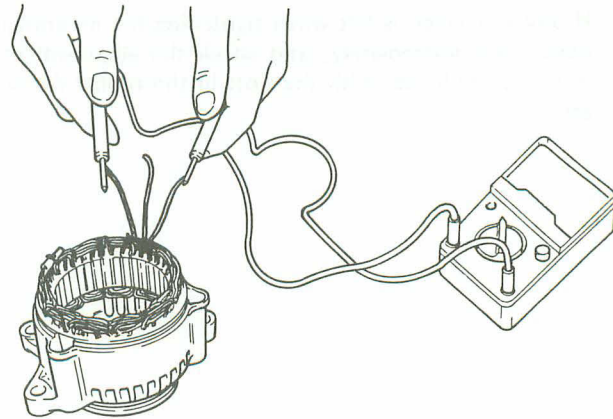

- ★ If the meter does not read as specified, replace the stator coil.

Stator Coil Resistance

Less than 1.0 Ω

- Using the highest ohmmeter range, measure the resistance between the stator coil core and each of the coil windings.
- ★ If there is any reading at all, the stator coil winding has a short and must be replaced.

Rotor Coil Inspection

- Connect an ohmmeter (x 1 Ω range) between the slip rings and read the meter.

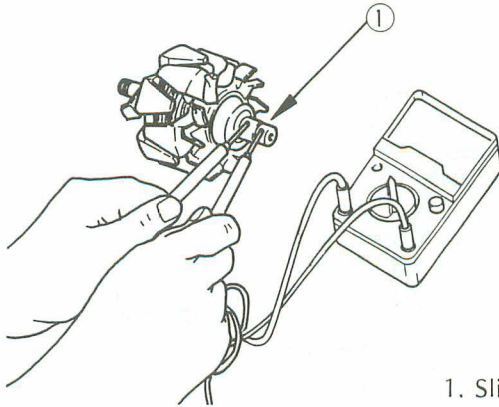

1. Slip Ring

- ★ If the meter does not read as specified, replace the rotor.

Rotor Coil Resistance

About 4 Ω (ZX1000-B1)

About 6 Ω (ZX1000-B2 and latest models)

- Using the highest ohmmeter range, measure the resistance between the rotor shaft and each of the slip rings.
- ★ If there is any reading at all, the rotor coil has a short and must be replaced.

Slip Ring Cleaning

- Visually inspect the slip ring for dirt or pitting.
- ★ If necessary, smooth the slip ring with No. 300 – No. 500 emery cloth.

Slip Ring Diameter

- ★ If the measurement is less than the service limit, replace the rotor.

Slip Ring Diameter

Standard: 14.4 mm

Service Limit: 14.0 mm

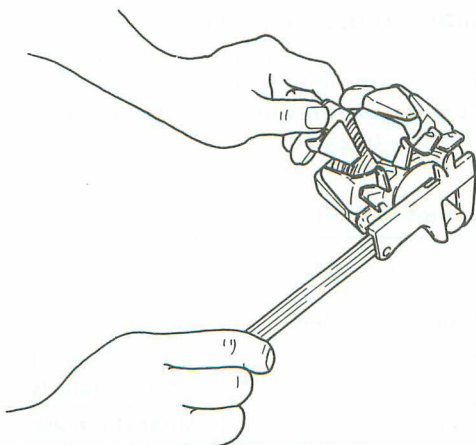

Carbon Brush Length

- Measure the length of both carbon brushes that stick out of the housing.
- ★ If either one is worn down to less than the service limit replace it.

Carbon Brush Length (projected portion)

Standard: 10.5 mm

Service Limit: 4.5 mm

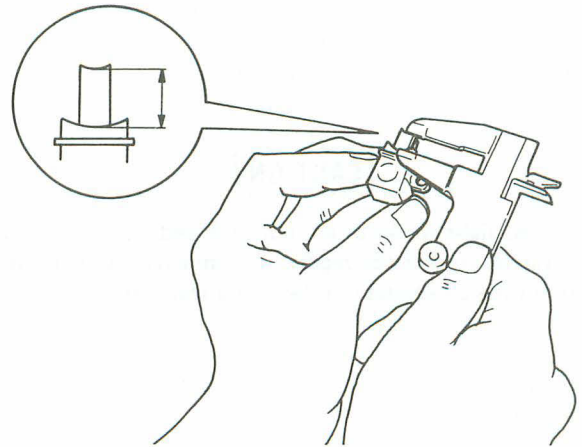

Rectifier Inspection

- Set an ohmmeter to the 1 kΩ range.
- Check the resistance of the diode in both directions.
- ★ If any diode shows low or high resistance in both directions, the diode is defective and the rectifier must be replaced.

NOTE

- The actual meter reading varies with the meter used and the individual diode, but, generally speaking, the lower reading should be from zero to half the scale.

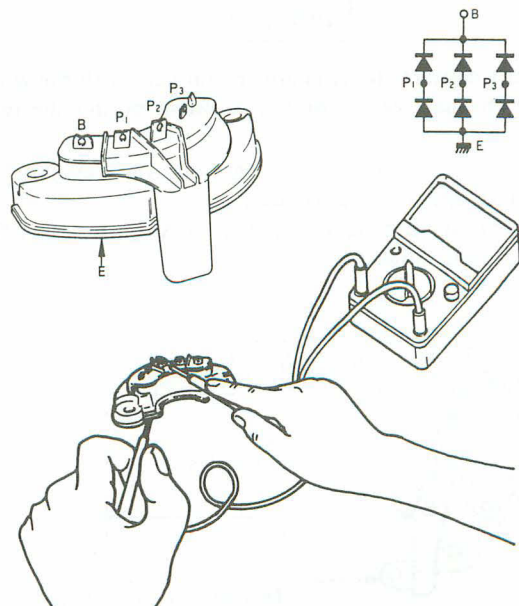

15-16 ELECTRICAL SYSTEM

CAUTION

○If a megger or a meter with a large-capacity battery is used, the rectifier will be damaged.

Regulator Inspection

●Prepare testing tools.

Test light: Bulb rated 12 V 3.4 W
 Batteries: Two 12 V batteries
 Test wires: Three auxiliary wires

CAUTION

○The test light works as an indicator and also a current limiter to protect the regulator from excessive current. Do not use an ammeter instead of a test light.

●Connect the test light and the 12 V battery to the regulator as shown.

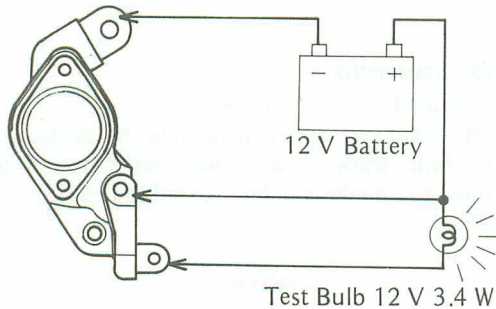

○The test light should go on at this time.

CAUTION

○Do not contact the regulator metal case with the wires from the battery (+) or (-) terminal during the test.

★If the test light does not go on, the regulator is damaged and must be replaced.

●Connect the test light and two 12 V batteries to the regulator as shown.

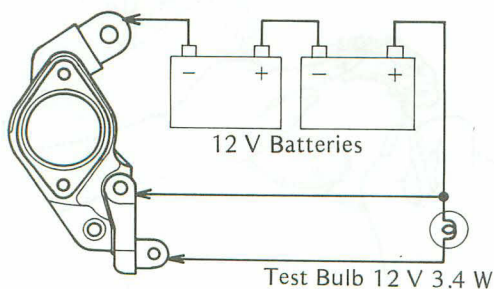

○The test light should not go on at this time.

★If the test light goes on, the regulator is damaged and must be replaced.

●Check the regulator internal resistance as shown.

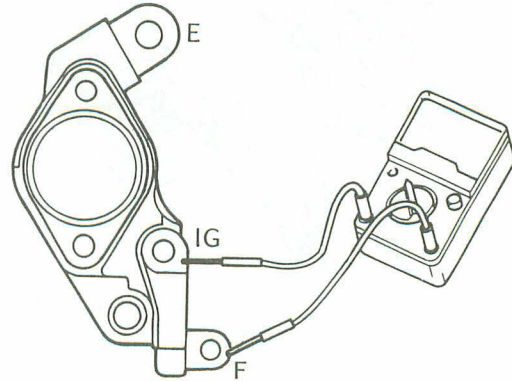

Regulator Internal Resistance

Meter Range	Connections		Reading
	Meter (+) to	Meter (-) to	
x 100 Ω	F	E	170 Ω
x 1 k Ω	E	F	4 k Ω
x 100 Ω	IG	E	800 Ω
x 1 k Ω	E	IG	2 k Ω
x 1 k Ω	F	IG	2 k Ω
x 100 Ω	IG	F	150 Ω

★Meter readings should be nearly values shown in the table. If the resistance is infinity (no reading) or 0 Ω , the regulator is damaged and must be replaced.

Alternator Troubleshooting:

For any charging system problems, always check the charging system wiring first (see Wiring Inspection), and then check the system with the following tests shown in the troubleshooting guide.

Troubleshooting Guide

Test No.	Trouble	Symptoms
1	Battery discharged	Starter not turning
2	Battery overcharged	Electrolyte level lowering quickly
3	Noise	Alternator noise

Test No.1-Battery Discharged

- Remove the nuts holding the alternator cover, and take off the cover.
- Check that the alternator leads and connectors are in good condition.
- ★ If not, repair or replace the damaged parts.
- Replace the discharged battery with a good battery.
- Check battery voltage with the engine running.
- ★ If the battery voltage is higher than 13.5 V, the charging system is in good condition.
- ★ If the battery voltage is lower than 13.5 V, check the following.
- Ground the F terminal of the regulator to the chassis with a auxiliary wire.

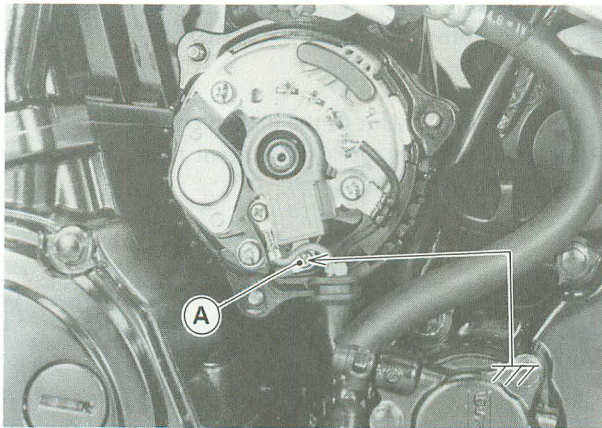

A. F Terminal

- Start the engine, and check the battery voltage with the engine running.
- ★ If the battery voltage is higher than 13.5 V, check the following.
 - Regulator
- ★ If the battery voltage is lower than 13.5 V, check the following.
 - Carbon brushes, Slip rings
 - Rectifier
 - Stator coil
 - Rotor coil

Test No.2-Battery Overcharged

- Check the regulator and/or rotor.
- ★ Repair or replace the damaged parts.

Test No.3-Noise

- Check the ball bearings, stator coil, and/or rectifier if the alternator makes a noise.
- ★ Repair or replace the damaged parts.

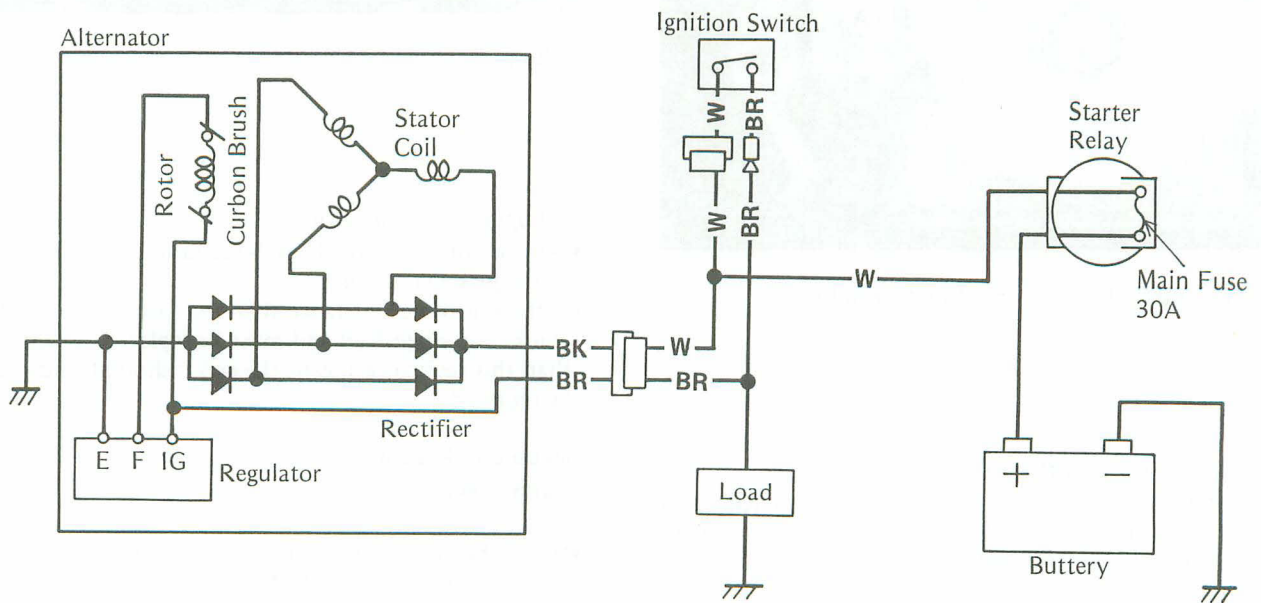

15-18 ELECTRICAL SYSTEM

Ignition System

WARNING

- The ignition system produces extremely high voltage. Do not touch the spark plugs, high tension coils, or spark plug leads while the engine is running, or you could receive a severe electrical shock.

CAUTION

- Do not disconnect the battery leads or any other electrical connections when the ignition switch is on, or while the engine is running. This is to prevent IC igniter damage.
- Do not install the battery backwards. The negative side is grounded. This is to prevent damage to the diodes and IC igniter.

Pickup Coil Removal

- Remove the following.
 - Fairings
 - Pickup Coil Lead Connector
 - Pickup Coil Cover

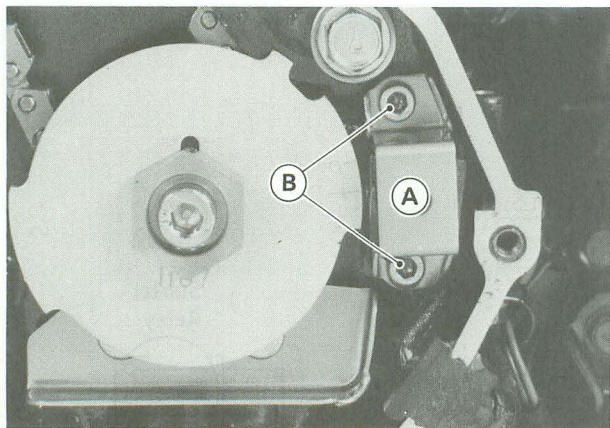

A. Pickup Coil B. Mounting Bolts

Pickup Coil Installation

- Install the pickup coil so that the air gap (clearance between the timing rotor projection and the pickup coil core) has correct clearance.

Pickup Coil Air Gap

0.7 mm

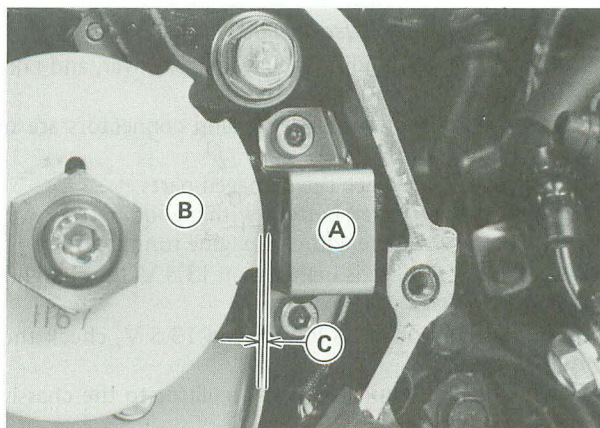

A. Pickup Coil C. Air Gap
B. Timing Rotor

- Apply silicone sealant to the pickup coil grommet.
- Apply non-permanent locking agent to the two upper left of pickup coil cover bolts.

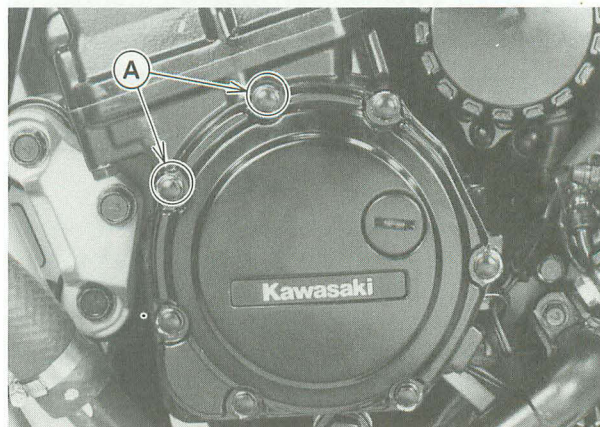

A. Bolts requiring locking agent

Pickup Coil Inspection

- Set the ohmmeter to the x 1 k Ω range, and connect it to the pickup coil wires.
- ★If there is more resistance than the specified value, the coil has an open lead and must be replaced. Much less than this resistance means the coil is shorted, and must be replaced.

Pickup Coil Resistance

400 – 490 Ω

- Using the highest resistance range of the ohmmeter, measure the resistance between the pickup coil leads and chasis ground.
- ★Any meter reading less than infinity (∞) indicates a short, necessitating replacement of the pickup coil assembly.

Ignition Coil Removal/Installation

- Remove the fuel tank.
- Disconnect the leads and remove the ignition coils.

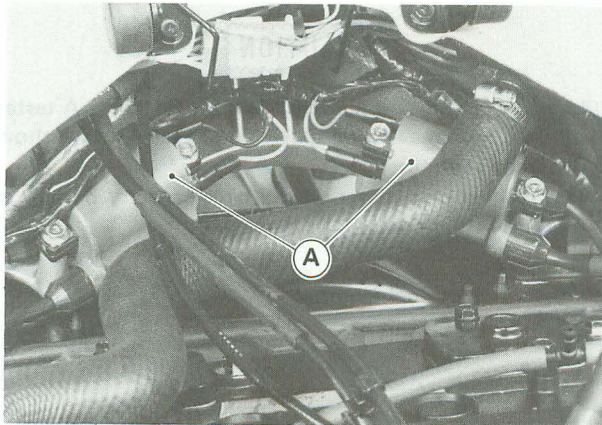

A. Ignition Coils

- Install the ignition coil. Note the following.
- Connect the primary winding leads to the ignition coil terminals.

Black Lead → to #1, #4 Coil
 Green Lead → to #2, #3 Coil
 Red Leads → to both Coils

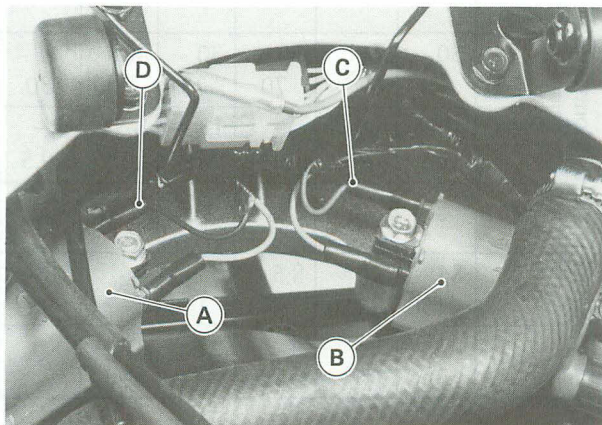

A. #1, #4 Coil
 B. #2, #3 Coil
 C. Green Lead
 D. Black Lead

Ignition Coil Inspection

NOTE

- The most accurate test for determining the condition of the ignition coil is made by measuring arcing distance with an ignition coil tester (special tool) using the 3-needle method.

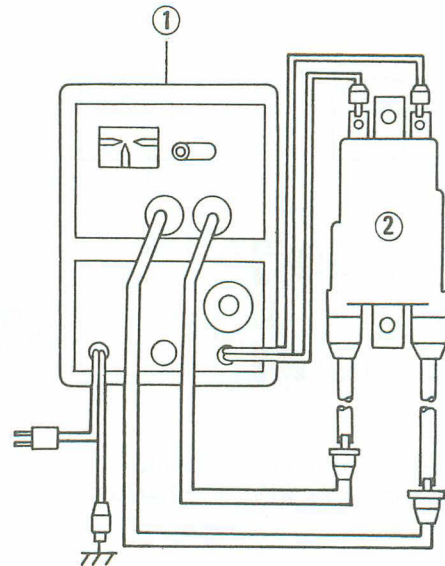

1. Ignition Coil Tester: 57001-1242
 2. Ignition Coil

WARNING

- To avoid extremely high voltage shocks, do not touch the coil or lead.

- ★ If the distance reading is less than the specified value, the ignition coil or spark plug caps are defective.

Ignition Coil Arcing Distance

6 mm or more

- To determine which part is defective, measure the arcing distance again with the spark plug caps removed from the ignition coil.
- ★ If the arcing distance is subnormal as before, the trouble is with the ignition coil itself. If the arcing distance is now normal, the trouble is with the spark plug caps.
- If the arcing tester is not available, the coil can be checked for a broken or badly shorted winding with an ohmmeter.

NOTE

- An ohmmeter cannot detect layer shorts and shorts resulting from insulation breakdown under high voltage.

- Measure the primary winding resistance as follows.
 - Connect an ohmmeter between the coil terminals.
 - Set the meter to the x 1 Ω range, and read the meter.
- Measure the secondary winding resistance as follows.
 - Connect an ohmmeter between the spark plug leads.
 - Set the meter to the x 1 k Ω , and read the meter.

15-20 ELECTRICAL SYSTEM

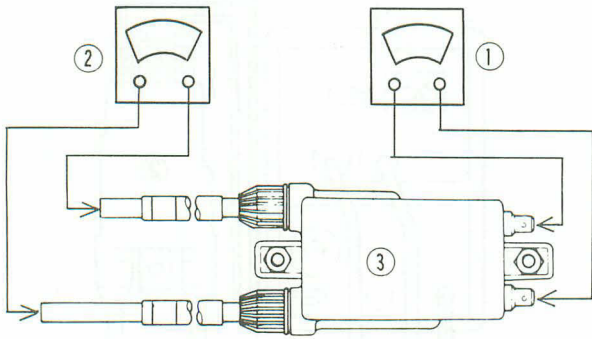

1. Measure primary winding resistance
2. Measure secondary winding resistance
3. Ignition Coil

● If the meter does not read as specified, replace the coil.

Ignition Coil Winding Resistance

Primary windings: 2.6 – 3.2 Ω
 Secondary windings: 13 – 17 kΩ

Spark Plug Gap

● Measure the gap with a wire-type thickness gauge.
 ★ If the gap is incorrect, carefully bend the side electrode with a suitable tool to obtain the correct gap.

Spark Plug Gap

0.7 – 0.8 mm

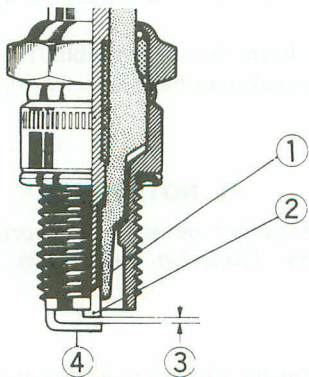

1. Insulator
2. Center Electrode
3. Plug Gap
4. Side Electrode

IC Igniter Inspection

- Set the ohmmeter to the x 1 kΩ range and make the measurements shown in the table.
- ★ If the meter readings are not as specified, replace the IC igniter.

CAUTION

- Use only Hand Tester 57001-983 for this test. A tester other than the Kawasaki Hand Tester may show different readings.
- If a megger or a meter with a large-capacity battery is used, the IC igniter will be damaged.

Connector Terminal Number

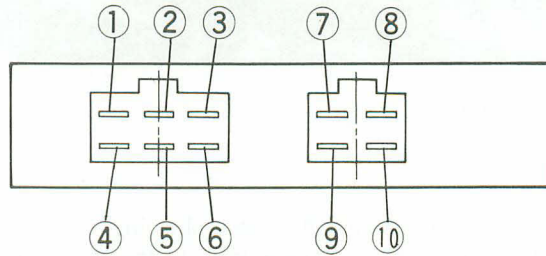

(kΩ)

		Tester (+) Lead Connection						
		Terminal No.	1	2	3	4	5	6
Tester (-) Lead Connection	1		∞	∞	∞	∞	∞	∞
	2	30 – 70		30 – 70	30 – 70	40 – 100	18 – 30	
	3	13 – 45	15 – 70		13 – 45	8.5 – 13	5 – 9.5	
	4	∞	∞	∞		∞	∞	
	5	35 – 150	40 – 150	8.5 – 13	35 – 150		18 – 35	
	6	2 – 3.8	2.6 – 5	4 – 6.5	2 – 3.8	12 – 24		

(kΩ)

		Tester (+) Lead Connection				
		Terminal Number	7	8	9	10
Tester (-) Lead Connection	7		∞	∞	∞	
	8	∞		∞	35 – 70	
	9	∞	∞		∞	
	10	∞	28 – 60	∞		

15-22 ELECTRICAL SYSTEM

IC Igniter Troubleshooting:

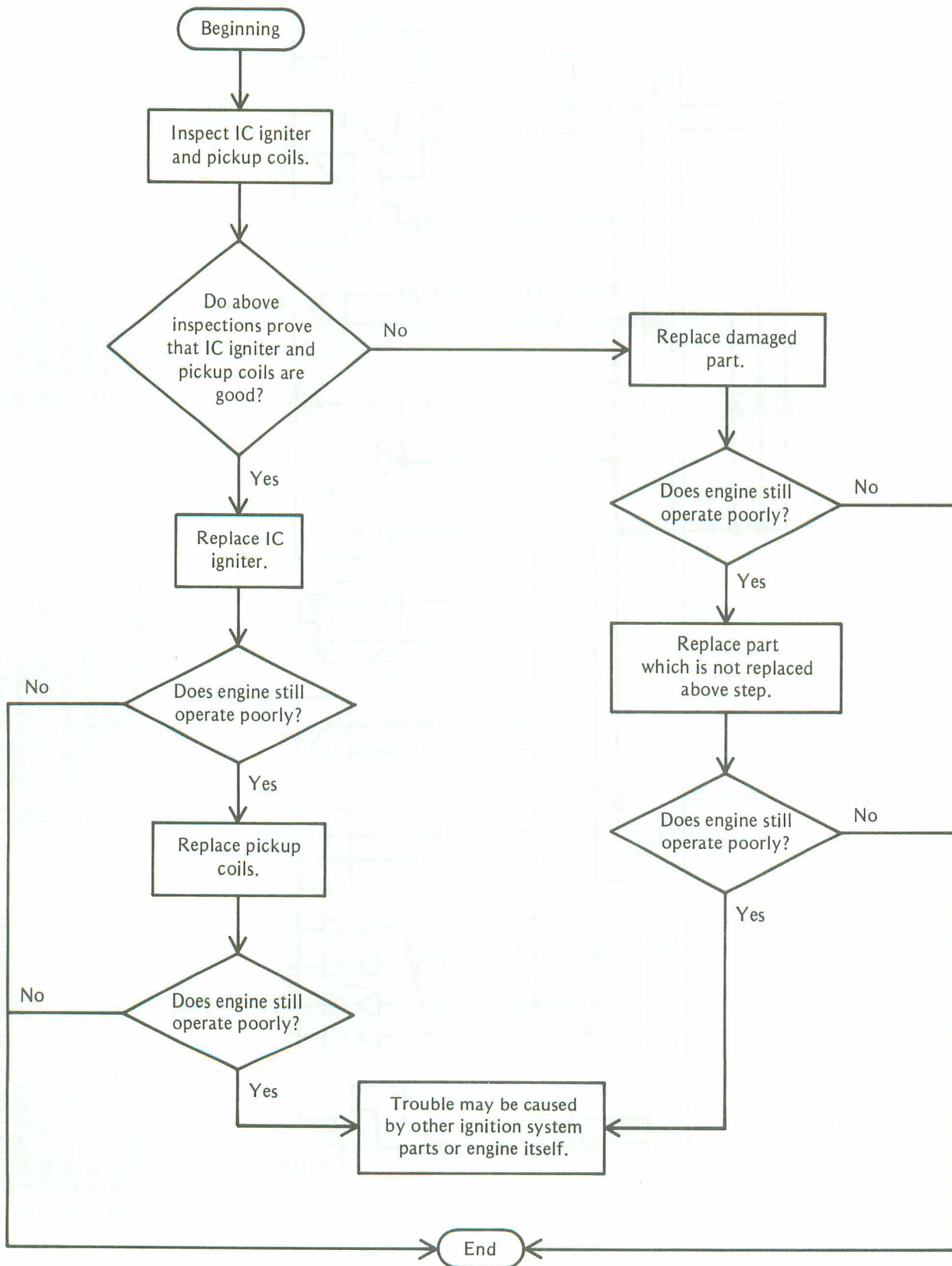

Electric Starter System

Starter Motor Removal

- Remove the engine (see Engine Removal/Installation chapter).
- Remove the following.
 - Engine Oil (Drain)
 - External Shift Mechanism Cover
 - Starter Motor Cable
- Remove the starter motor mounting bolts and pull out the starter motor.

CAUTION

○ Do not tap the starter motor shaft or body. Tapping on the shaft or body could damage the motor.

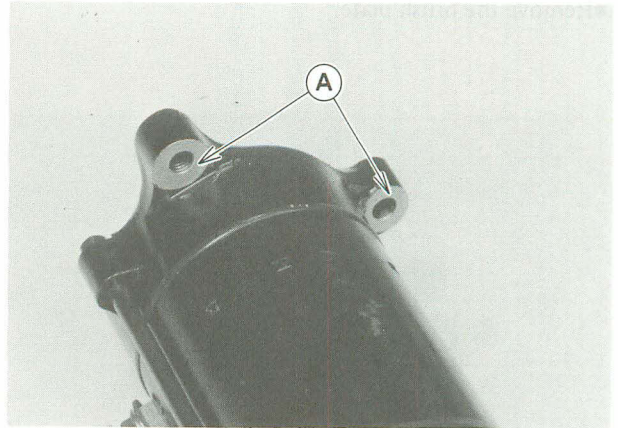

A. Clean here.

- Apply a small amount of engine oil to the O-ring.

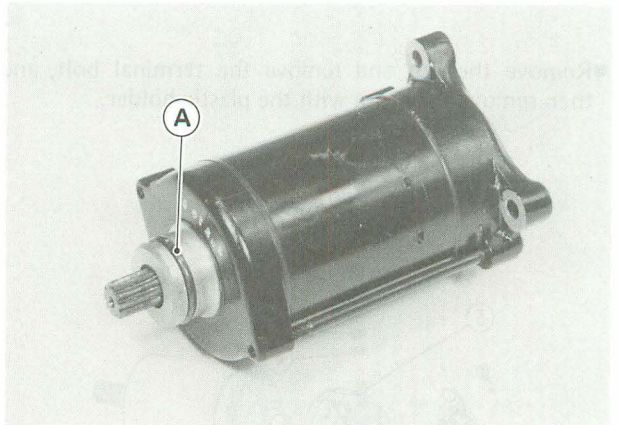

A. O-ring

Starter Motor Installation

- Installation is the reverse of removal. Note the following.
- Clean the starter motor legs and crankcase where the starter motor is grounded.

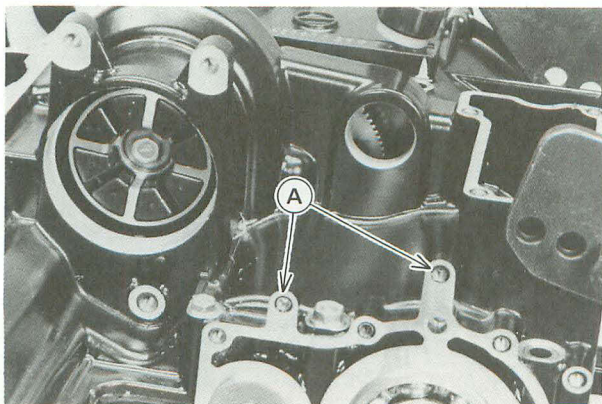

A. Clean here.

Disassembly

- Remove the both end covers and pull the armature out of the yoke.

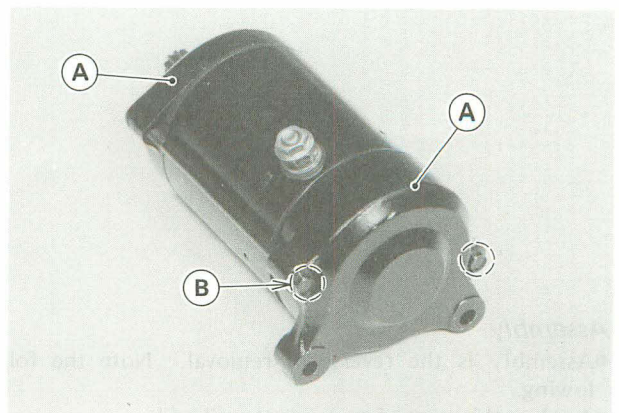

A. End Covers

B. Bolts

15-24 ELECTRICAL SYSTEM

- Remove the brush plate.

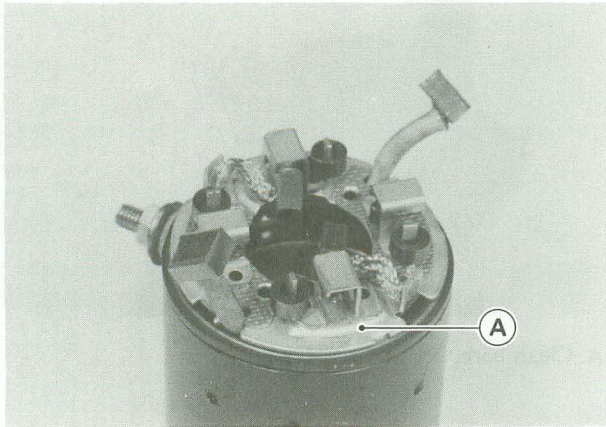

A. Brush Plate

- Remove the nut and remove the terminal bolt, and then remove the brush with the plastic holder.

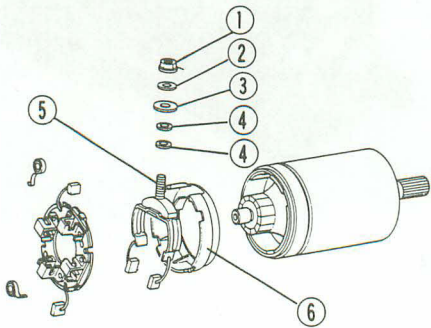

1. Nut
2. Washer
3. Large Washer (Plastic)
4. Small Washer (Plastic)
5. Terminal Bolt
6. Plastic Holder

Assembly

- Assembly is the reverse of removal. Note the following.
- Apply a thin coat of grease to the oil seal.
- Fit the toothed washer to the end cover.

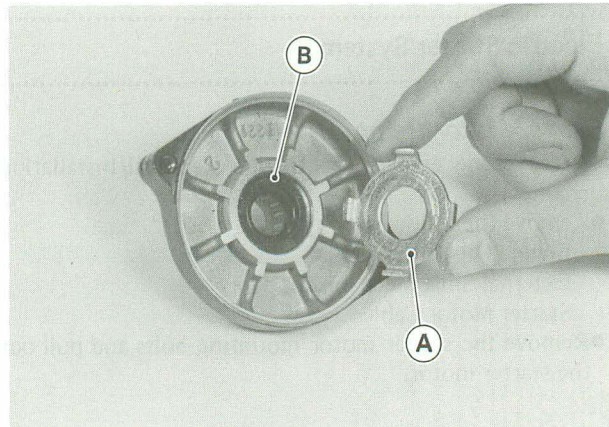

A. Toothed Washer B. Oil Seal

- Fit the tongue on the brush plate into the end cover groove.

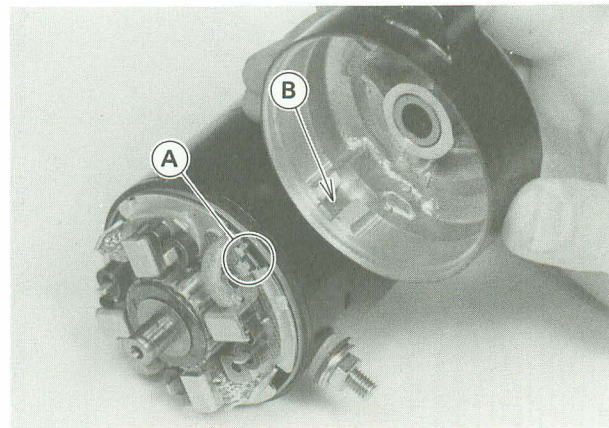

A. Tongue B. Groove

- Align the mark on the end cover with the terminal bolt.

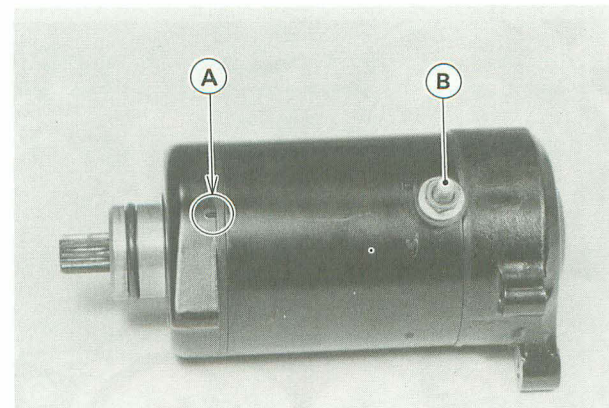

A. Mark B. Terminal Bolt

Brush Inspection

- Measure the length of each brush.
- ★ If any is worn down to the service limit, replace all brushes.

Starter Motor Brush Length

Standard:	12 mm
Service Limit:	8.5 mm

Commutator Diameter

Standard:	28 mm
Service Limit:	27 mm

Commutator Cleaning and Inspection

- Smooth the commutator surface if necessary with fine emery cloth, and clean out the grooves as illustrated.

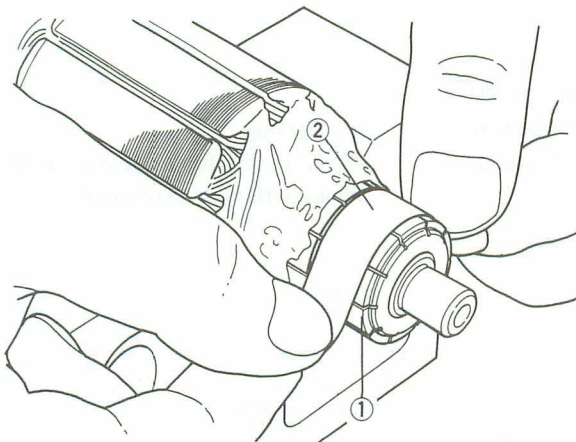

1. Commutator 2. Emery Cloth

- Measure the diameter of the commutator.
- ★ Replace the starter motor with a new one if the commutator diameter is less than the service limit.

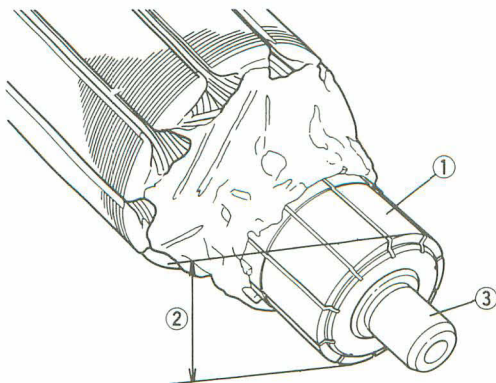

1. Commutator Segment 3. Shaft
2. Diameter

Armature Inspection

- Using the x 1 Ω ohmmeter range, measure the resistance between any two commutator segments.
- ★ If there is a high resistance or no reading (∞) between any two segments, a winding is open and the starter motor must be replaced.

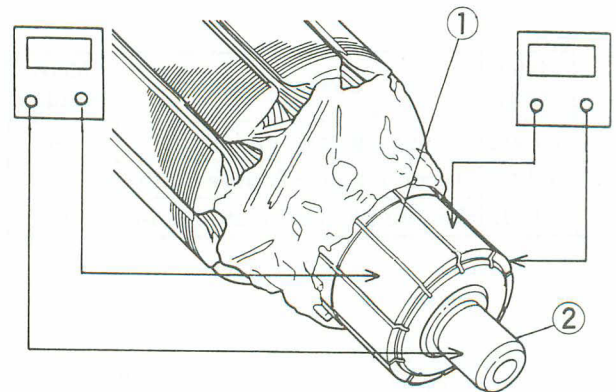

1. Segment 2. Shaft

- Using the highest ohmmeter range, measure the resistance between the commutator and the shaft.
- ★ If there is any reading at all, the armature has a short and the starter motor must be replaced.

15-26 ELECTRICAL SYSTEM

NOTE

○Even if the foregoing checks show the armature to be good, it may be defective in some manner not readily detectable with an ohmmeter. If all other starter motor and starter motor circuit components check good, but the starter motor still does not turn over or only turns over weakly, replace the starter motor with a new one.

Negative Brush and Lead Assembly Inspection

- Using the $\times 1 \Omega$ ohmmeter range, measure the resistance as follows.
 - Between the brush and brush plate.
 - Between the brush holder and brush plate.

Brush Plate Inspection

- Measure the resistance as follows.

	Meter Range	Connections	Meter Reading
A	$\times 1 \text{ k}\Omega$	Terminal Bolt \leftrightarrow Brush Plate	∞
B	$\times 1 \Omega$	Terminal Bolt \leftrightarrow Positive Brush	0Ω
C	$\times 1 \text{ k}\Omega$	Positive Brush \leftrightarrow Negative Brush	∞

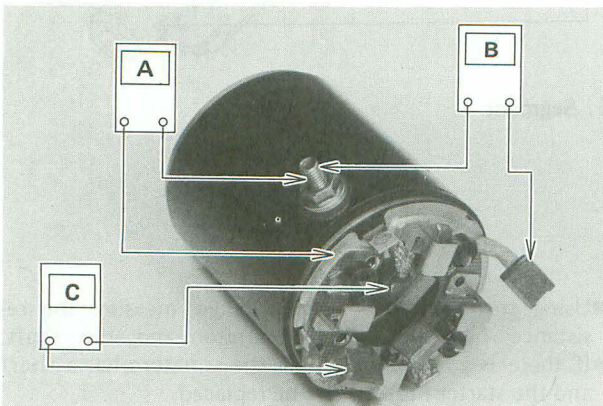

- ★If the meter does not read as specified, check the terminal bolt insulations.
- ☆If the terminal bolt insulations are not defective, replace the brush plate.

Starter Relay Inspection

- Remove the starter relay.
- Connect the ohmmeter and 12 V battery to the starter relay as shown.
- ★If the relay does not work as specified, the relay is defective. Replace the relay.

Testing Relay

- Meter Range: $\times 1 \Omega$ range
 Criteria: When battery is connected $\rightarrow 0 \Omega$
 When battery is disconnected $\rightarrow \infty$

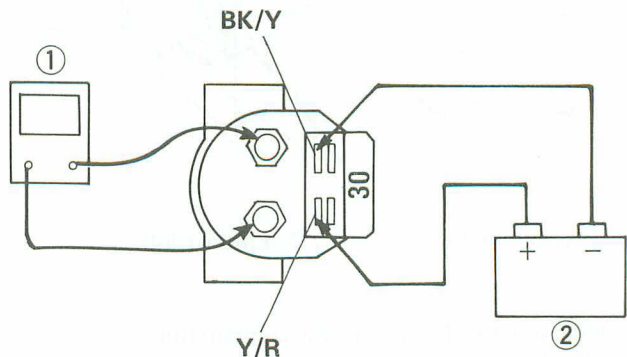

1. Tester

2. 12 V Battery

1. Ignition Switch
2. 6-pin Connector
3. Engine Stop Switch
4. Starter Button
5. 9-pin Connector
6. Junction Box
7. Starter Circuit Relay
8. 10-pin Connector
9. 2-pin Connector
10. Starter Lockout Switch
11. Neutral Switch
12. Starter Motor
13. Starter Relay
14. Main Fuse 30A
15. Battery

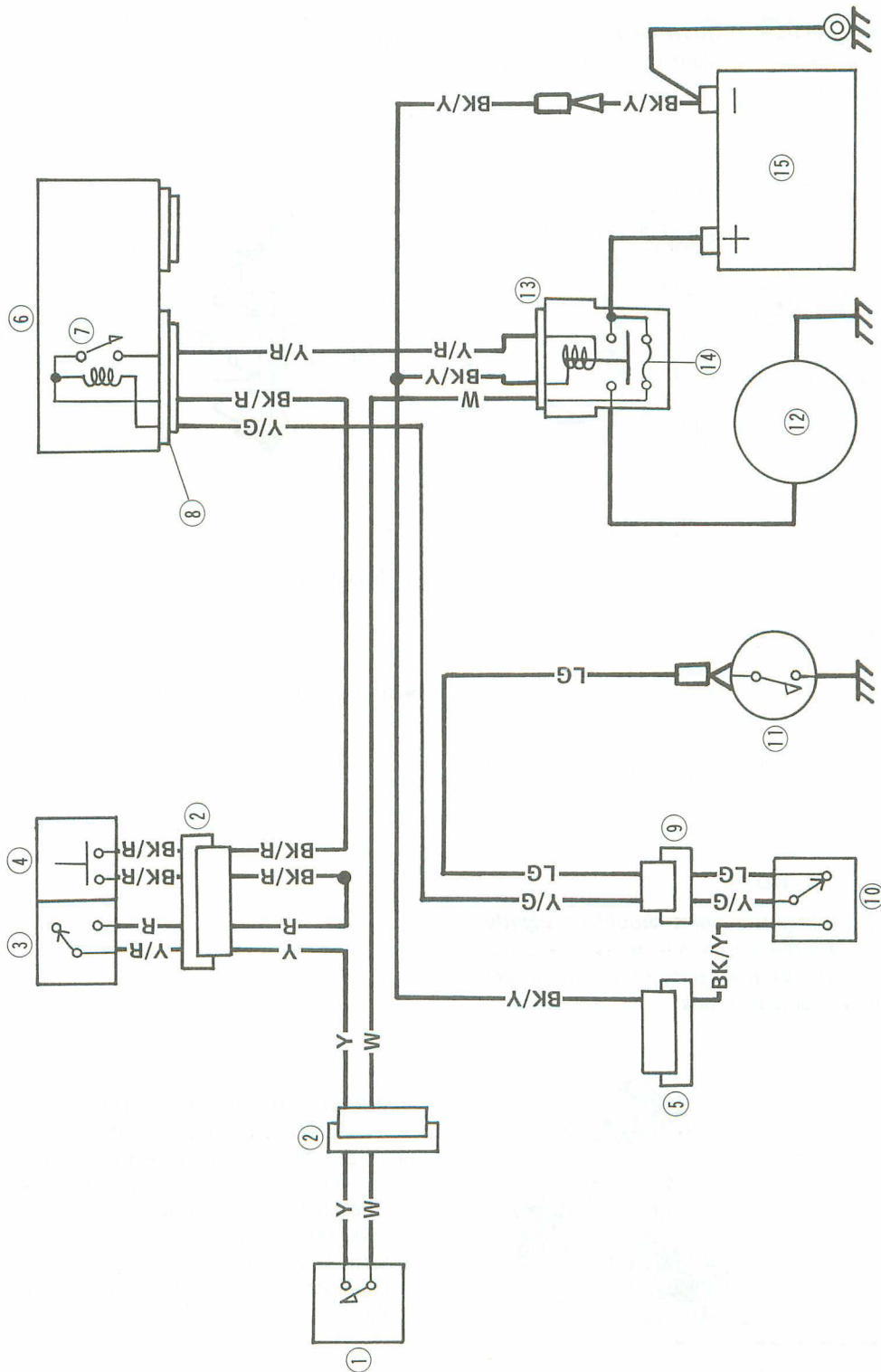

15-28 ELECTRICAL SYSTEM

Headlight

Headlight Beam Horizontal Adjustment

- Turn the adjuster on the headlight in or out until the beam points straight ahead.

Headlight Beam Vertical Adjustment

- Turn the adjuster on the headlight in or out to adjust the headlight vertically.

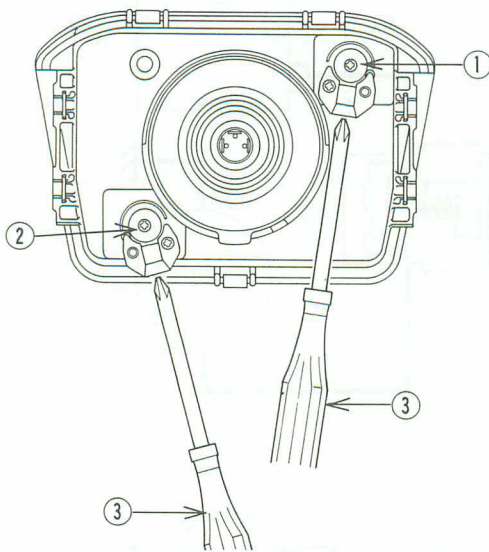

1. Horizontal Adjuster 3. Phillips Screwdriver
2. Vertical Adjuster

NOTE

- On high beam, the brightest point should be slightly below horizontal with the motorcycle on its wheels and the rider seated. Adjust the headlight to the proper angle according to local regulations.

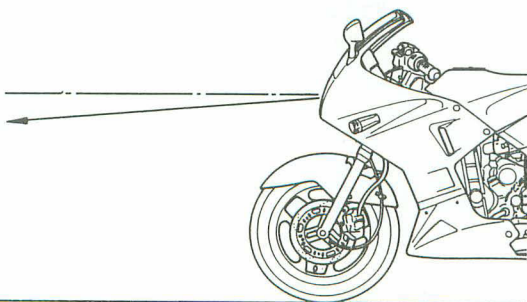

Headlight Bulb Replacement Notes

CAUTION

- When handling the quartz-halogen bulbs, never touch the glass portion with bare hands. Always use a clean cloth. Oil contamination from hands or dirty rags can reduce bulb life or cause the bulb to explode.
- Fit the dust cover onto the bulb firmly as shown in the figure.

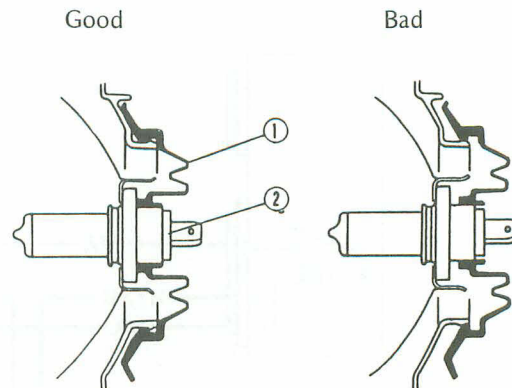

1. Dust Cover 2. Bulb

- After installation, adjust the headlight aim.

Headlight Circuit Inspection

The US and Canadian models contain a relay in the headlight circuit. In these models, the headlight does not go on when the ignition switch is first turned on, but the headlight goes on once the starter button is pushed to start the engine, and stays on until the ignition switch is turned off. But the headlight goes out whenever the starter button is pushed to restart the engine after engine stalling.

1. Ignition Switch
2. 6-pin Connector
3. Starter Relay
4. 4-pin Connector
5. Junction Box
6. Starter Circuit Relay
7. Headlight Relay
8. Headlight Fuse 10A
9. Diode
10. Headlight
11. High Beam Indicator Light
12. Battery
13. 10-pin Connector
14. 8-pin Connector
15. Dimmer Switch
16. 9-pin Connector
17. Main Fuse 30A

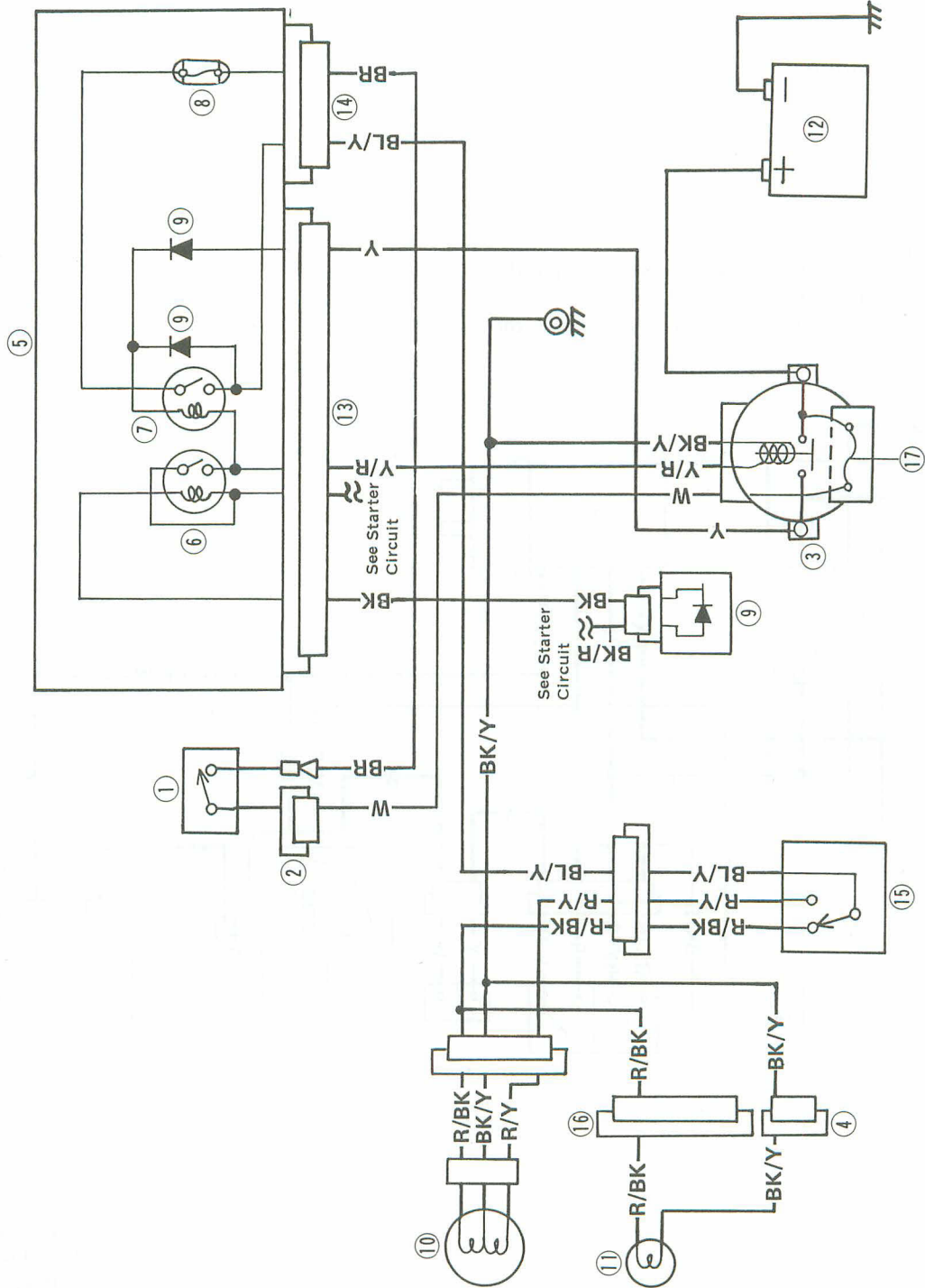

15-30 ELECTRICAL SYSTEM

Fuel Pump

The pump operates when the starter button is pushed on or the engine is running.

When fuel level in the float chamber is low, the fuel pump operates to supply fuel into the float chamber.

When the fuel reaches a certain level, the fuel pressure rises, and fuel pump stop.

Removal/Installation

- Refer to the fuel system chapter.

Inspection

Internal Resistance

- Set the ohmmeter to the x 1 k Ω range and make the measurements shown in the table.
- ★If the meter readings are not as specified, replace the fuel pump.

Fuel Pump Internal Resistance

		Tester (+) Lead Connection		
		R	BK	Y
Tester (-) Lead Connection	R	/	∞	∞
	BK	∞	/	∞
	Y	∞	More than 20 k Ω	/

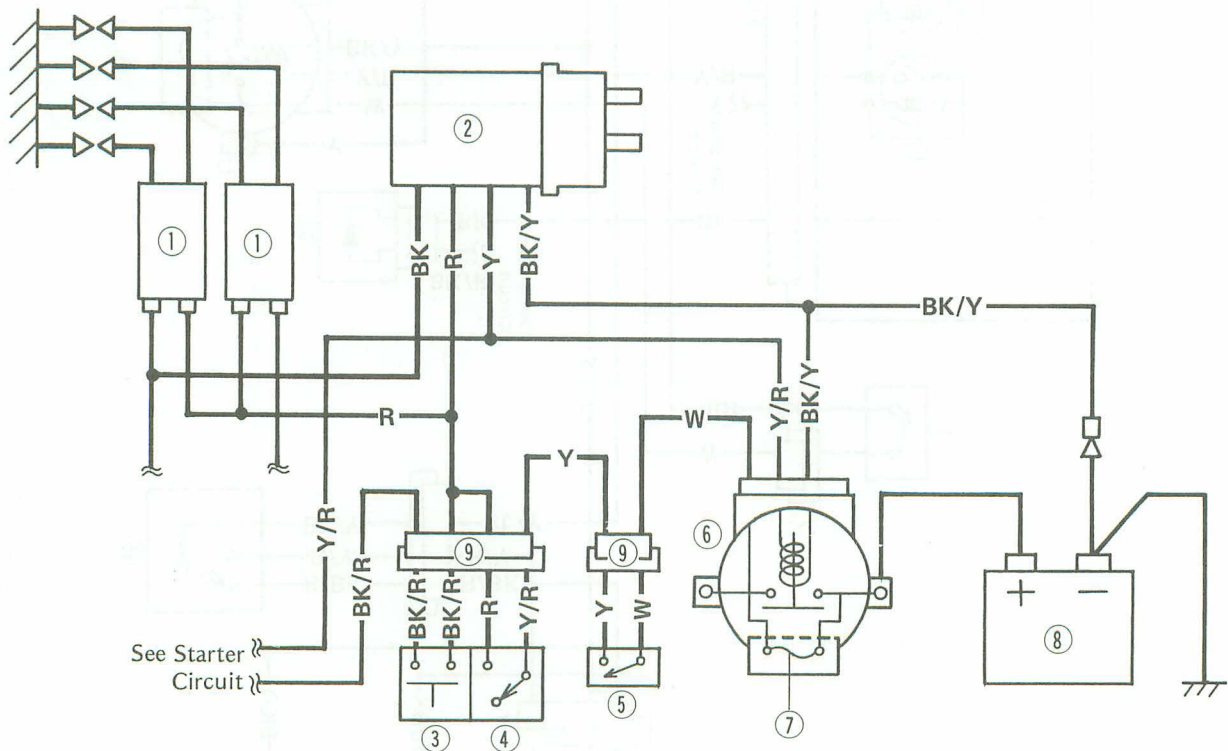

1. Ignition Coil
2. Fuel Pump
3. Start Button
4. Engine Stop Switch
5. Ignition Switch
6. Starter Relay
7. Main Fuse 30A
8. Battery
9. 6-pin Connector

Check for Proper Operation

- Remove the fuel pump with fuel filter.
- Prepare a container filled with kerosene.
- Prepare the rubber hoses, and connect them to the pump fittings.
- Connect the suitable pressure gauge to the outlet hose as shown.

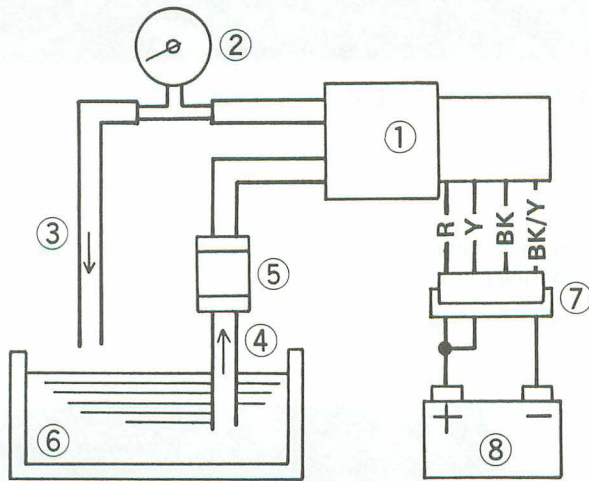

1. Fuel Pump
2. Pressure Gauge
3. Outlet Hose
4. Inlet Hose
5. Fuel Filter
6. Kerosene
7. 4-pin Connector
8. Battery

- Prepare the 4-pin connector with wires, and connect it into the pump wire connector.
- Connect the battery + wire to the Red and Yellow wires, then battery - wire to the Black/Yellow wire at the pump connector.
- ★ If the pump does not operate, the pump is defective.
- Close the outlet hose while operating the fuel pump.
- When the pump is stopped, read the pressure gauge.
- ★ If the pressure gauge reading out of the specified pressure, the pump is defective.

Fuel Pump Pressure

Standard: 11 – 16 kPa
(0.11 – 0.16 kg/cm², 1.6 – 2.3 psi)

Cooling Fan System

Fan System Circuit Inspection

- Disconnect the cooling fan switch leads from the cooling fan switch (BL/BK and BL/W wires).
- Using an auxiliary wire, connect the cooling fan switch leads.
- ★ If the fan turns, inspect the following.
 - Switches (Fan Switch)
- ★ If the fan does not turn, inspect the following.
 - Wires and Connectors
 - Junction Box Parts (Fan Relay and Fan Fuse)
 - Main Fuse
 - Fan

Fan Inspection

- Disconnect the 2-pin connector in the fan leads.
- Using two auxiliary wires, supply battery power to the fan.
- ★ If the fan does not turn at this time, the fan is defective and must be replaced.

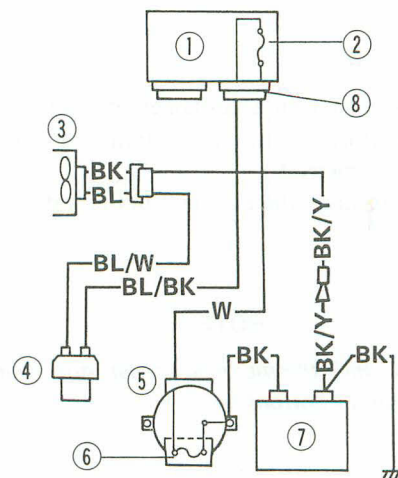

1. Junction Box
2. Fan Fuse 10A
3. Cooling Fan
4. Fan Switch
5. Starter Relay
6. Main Fuse 30A
7. Battery
8. 8-pin Connector

Fan Switch Inspection

- Using an ohmmeter measure the internal resistance of the sensor across the terminal and the body at the temperatures shown in the table.
- ★ If the ohmmeter does not show the specified values, replace the sensor.

Fan Switch Connections

- Rising temperature: From OFF to ON at 96 – 100°C (205 – 212°F)
- Falling temperature: From ON to OFF at 91 – 95°C (196 – 203°F)
- ON : Less than 0.5 Ω
- OFF : More than 1MΩ

15-32 ELECTRICAL SYSTEM

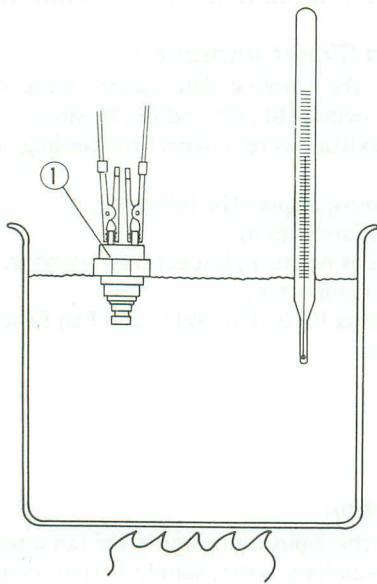

1. Fan Switch

- Suspend the switch in a container of coolant so that the temperature-sensing projection and threaded portion are submerged.
- Suspend an accurate thermometer in the water.

NOTE

- The switch and thermometer must not touch the container sides or bottom.

- Place the container over a source of heat and gradually raise the temperature of the water while stirring the water gently.

Meters, Gauges

Tachometer Removal

- Remove the following.
 - Wideshield
 - Inner Fairing
 - Meter Mounting Bolts



A. Meter Mounting Bolts

Speedometer Cable Wiring Connectors

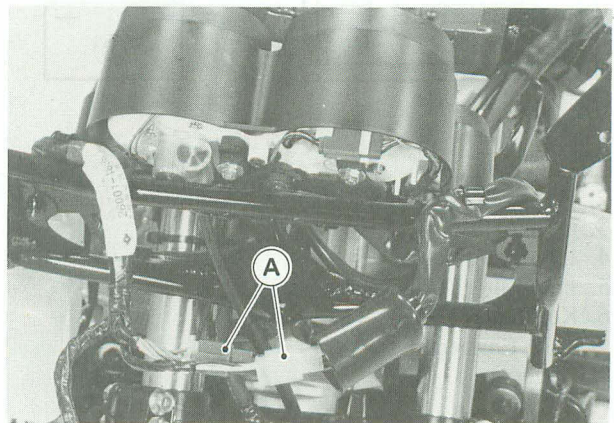

A. Wiring Connectors

CAUTION

- Place the meter or gauge so that the face is up. If a meter or gauge is left upside down or sideways for any length of time it will malfunction.

Tachometer Inspection

- Check the tachometer circuit wiring.
- ★ If all wiring, main fuse, ignition coil check out good, the unit is defective.

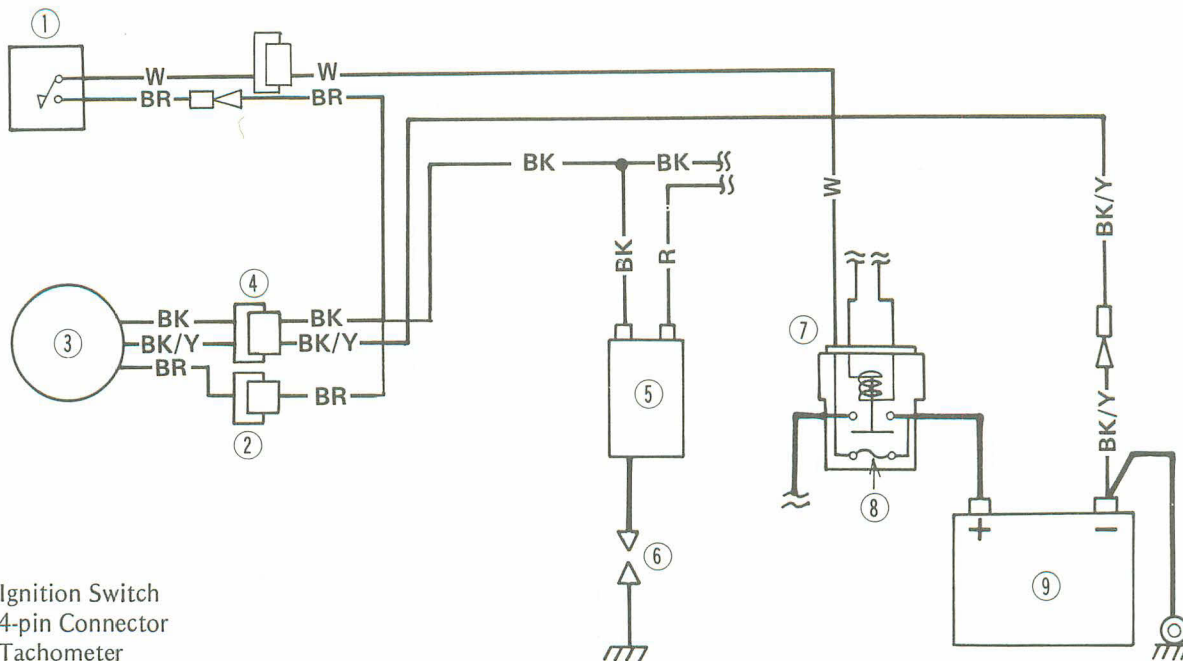

1. Ignition Switch
2. 4-pin Connector
3. Tachometer
4. 9-pin Connector
5. Ignition Coil (#1, #4)
6. Spark Plug
7. Starter Relay
8. Main Fuse 30A
9. Battery

Fuel Gauge Operation Inspection

- Prepare an auxiliary wire, and check the operation of the gauge.

Fuel Gauge Operation Check

Ignition Switch Position: ON

**Wire Location: Female 2-pin sensor connector
(disconnected)**

Results: Gauge should read E when connector wires are opened.

Gauge should read F when connector wires wires are shorted.

- ★ If the gauge readings are correct, the fuel level sensor is bad. If these readings are not obtained, the trouble is with the gauge and/or wiring.
- Check the fuel gauge circuit wiring (see Wiring Inspection).
- ★ If all wiring and components other than the fuel gauge unit check out good the gauge is defective.

Fuel Level Sensor Inspection

- Check that the float moves up and down smoothly without binding. It should go down under its own weight.
- ★ If the float does not move smoothly, replace the sensor.

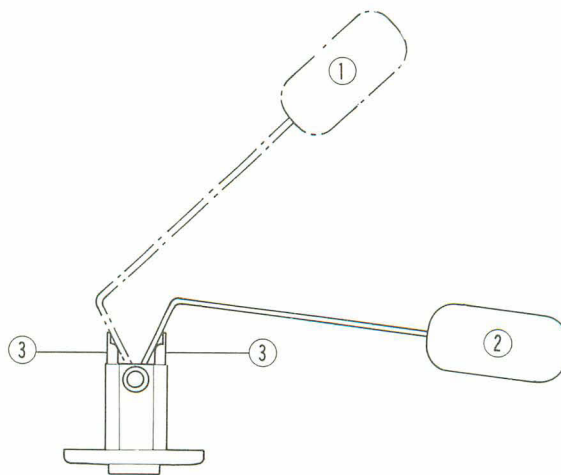

1. Float in full position.
2. Float in empty position
3. Float arm stop

- Measure the resistance of the fuel level sensor with an ohmmeter.

- ★ If the ohmmeter does not show the specified values, or the readings do not change smoothly as the float moves up and down, replace the sensor.

Fuel Level Sensor Resistance

Full Position:	4 – 10 Ω
Empty Position:	90 – 100 Ω

15-34 ELECTRICAL SYSTEM

- Inspect the leads and 2-pin connector.
- ★ If they show any signs of damage, replace the sensor.

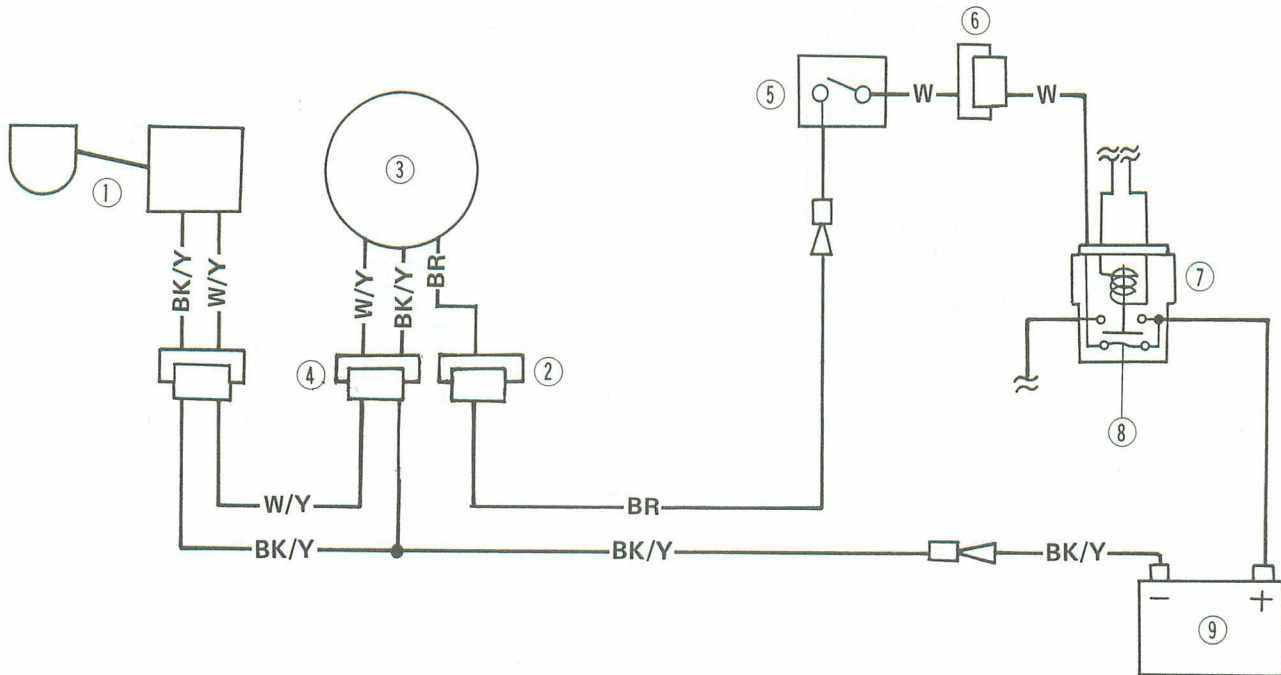

1. Fuel Level Sensor
2. 9-pin Connector
3. Fuel Gauge
4. 4-pin Connector
5. Ignition Switch

6. 6-pin Connector
7. Starter Relay
8. Main Fuse 30A
9. Battery

Water Temperature Gauge Operation Inspection

- Prepare an auxiliary wire, and check the operation of the gauge.

CAUTION

- Do not ground the wiring longer than necessary. After the needle swings to the H position, stop the test. Otherwise the gauge could be damaged.

Gauge Operation Test

Ignition Switch Position: ON

Wire Location: Female, Sensor Connector
(disconnected)

Results: Gauge should read C when sensor wire is opened.

Gauge should read H when connector wire wire is grounded to engine.

- ★ If these readings are not correct, the trouble is with the gauge and/or wiring.
- Check the water temperature gauge circuit wiring (see Wiring Inspection).
- If all wiring and components other than the water temperature gauge unit check out good, the gauge is defective.

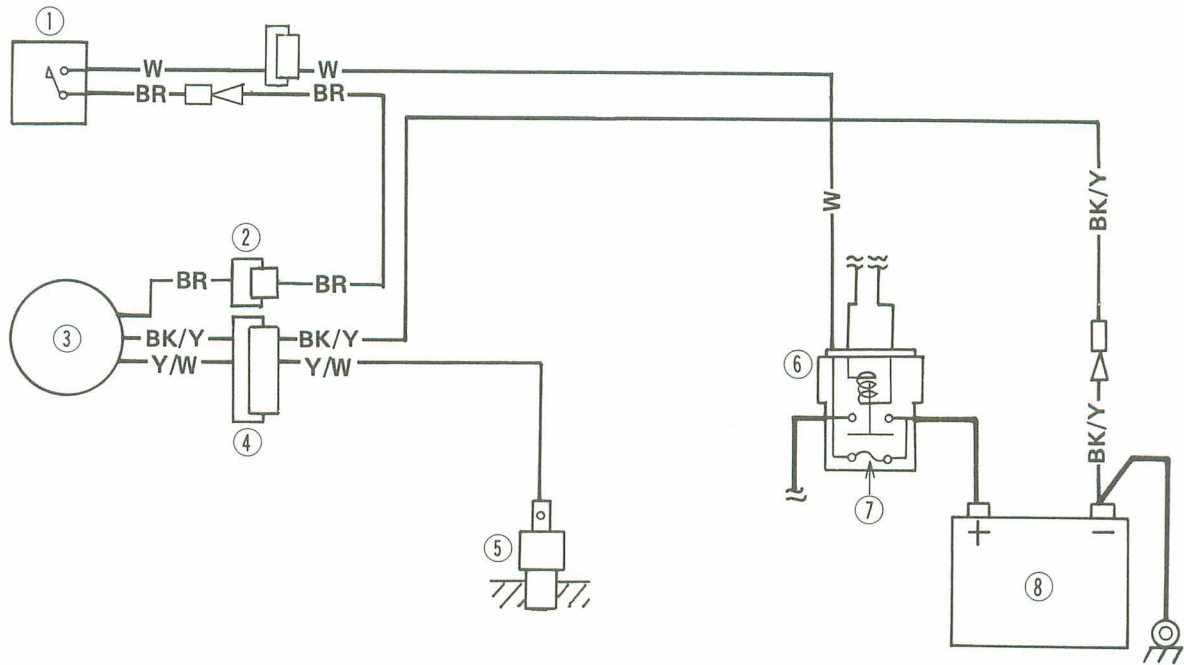

1. Ignition Switch
2. 9-pin Connector
3. Water Temperature Gauge
4. 4-pin Connector
5. Water Temperature Sensor

6. Starter Relay
7. Main Fuse 30A
8. Battery

Water Temperature Sensor Inspection

- Suspend the sensor in a container of water so that the temperature sensing projection and threaded portion are submerged.
- Using an ohmmeter, measure the internal resistance of the sensor across the terminal and the body at the temperatures shown in the table.

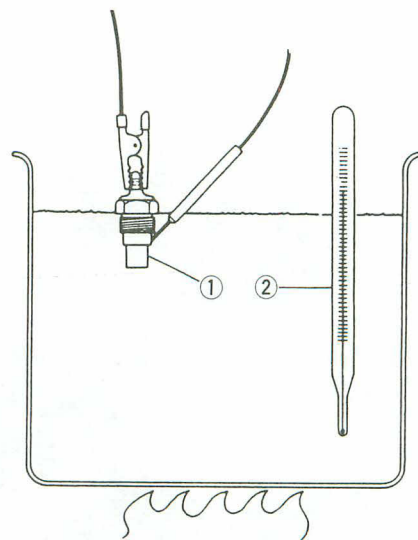

1. Water Temperature Sensor 2. Thermometer

15-36 ELECTRICAL SYSTEM

★If the ohmmeter does not show the specified values, replace the sensor.

NOTE

○The sensor and thermostat must not touch the container sides or bottom.

Junction Box

The junction box has fuses, relays and diodes. The relays and diodes can not be removed.

Fuse Removal

- Unlock the hook to lift up the locking arm.
- Pull the fuses straight out of the junction box with needle nose pliers.

Fuse Installation

★If a fuse fails during operation, inspect the electrical system to determine the cause, and then replace it with a new fuse of proper amperage.

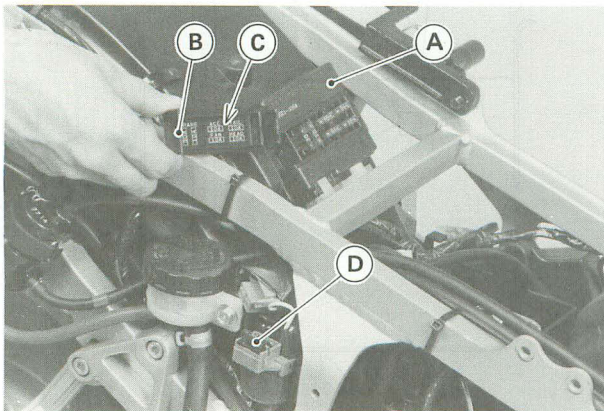

A. Junction Box
B. Fuse Cover
C. Label
D. Main Fuse

Fuse Inspection

- Inspect the fuse element.
- ★If it is blown out, replace the fuse. Before replacing a blown fuse, always check the amperage in the affected circuit. If the amperage is equal to or greater than the fuse rating, check the wiring and related components for a short circuit.

CAUTION

- When replacing a fuse, be sure the new fuse matches the specified fuse rating for that circuit. Installation of a fuse with a higher rating may cause damage to wiring and components.

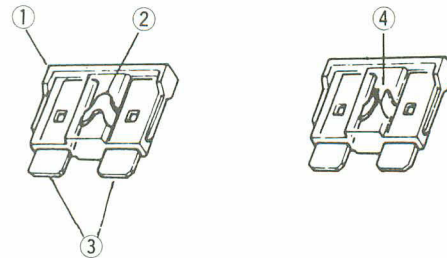

1. Housing
2. Fuse
3. Terminals
4. Blown Element

Junction Box Fuse Circuit Inspection

- Remove the junction box from the motorcycle.
- Pull off the connectors from the junction box.
- Make sure all connector terminals are clean and tight, and none of them have been bent.
- ★Clean the dirty terminals and, straighten slightly-bent terminals.
- Check conductivity of the numbered terminals with hand tester.
- ★If the meter does not read as specified, replace the junction box.

Fuse Circuit Inspection

Meter Connection	Meter Reading (Ω)
1 - 2	0
1 - 3A	0
6 - 7	0
6 - 17	0
1 - 7	∞
3A - 8	∞
8 - 17	∞

Starter-Circuit and Headlight Relay Inspection

- Remove the junction box from the motorcycle.
- Check conductivity of the following numbered terminals by connecting an ohmmeter and one 12 V battery to the junction box as shown.
- ★ If the relay does not work as specified, replace the junction box.

Relay Circuit Inspection (with the battery disconnected)

	Meter Connection	Meter Reading (Ω)
Headlight Relay	*7 - 8	∞
	*7 - 13	∞
Starter Relay	11 - 13	∞
	12 - 13	∞

Relay Circuit Inspection (with the battery connected)

	Meter Connection	Battery Connection		Meter Reading (Ω)
		+	-	
Headlight	*7 - 8	*9	- 13	0
Starter	11 - 13	11	- 12	0

*US, Canadian Models only

Diode Circuit Inspection

- Remove the junction box from the motorcycle.
- Pull off the connectors from the junction box.
- Check conductivity of the following pair of terminals.

Terminals for Diode Circuit Inspection

*13-8, *13-9, 12-14, 15-14, 16-14

*US, Canadian Models only

★ The resistance should be low in one direction and more than ten times as much in the other direction. If any diode shows low or high in both directions, the diode is defective and the diode assembly must be replaced.

NOTE

○ The actual meter reading varies with the meter used and the individual diode, but, generally speaking, the lower reading should be from zero to one half the scale.

Junction Box Internal Circuit

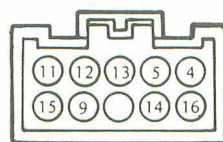
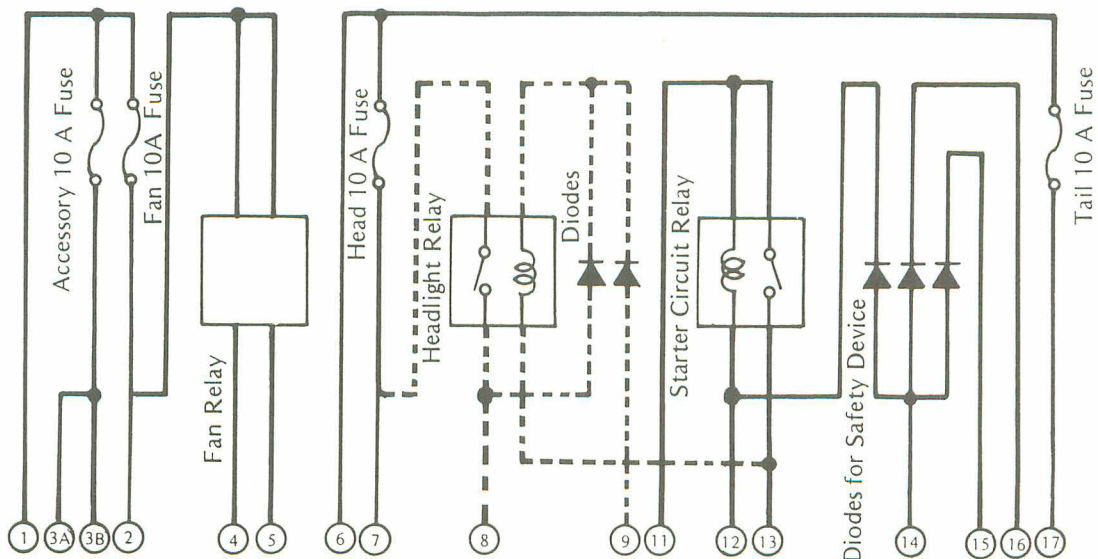

9-Pin Connector

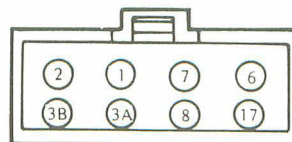

8-Pin Connector

--- for US, Canadian models

Appendix

Table of Contents

Additional Considerations for Racing	16-2
Carburetor	16-2
Spark Plug	16-2
Spark Plug Inspection	16-2
Troubleshooting Guide	16-4
General Lubrication	16-8
Lubrication	16-8
Nut, Bolt, and Fastener Tightness	16-8
Tightness Inspection	16-8
Unit Conversion Table	16-9

16-2 APPENDIX

Additional Considerations for Racing

This motorcycle has been manufactured for use in a reasonable and prudent manner and as a vehicle only. However, some may wish to subject this motorcycle to abnormal operation, such as would be experienced under racing conditions. KAWASAKI STRONGLY RECOMMENDS THAT ALL RIDERS RIDE SAFELY AND OBEY ALL LAWS AND REGULATIONS CONCERNING THEIR MOTORCYCLE AND ITS OPERATION.

Racing should be done under supervised conditions, and recognized sanctioning bodies should be contacted for further details. For those who desire to participate in competitive racing or related use, the following technical information may prove useful. However, please note the following important points.

- You are entirely responsible for the use of your motorcycle under abnormal conditions such as racing, and Kawasaki shall not be liable for any damages which might arise from such use.
- Kawasaki's Limited Motorcycle Warranty and Limited Emission Control Systems Warranty specifically exclude motorcycles which are used in competitive or related uses. Please read the warranty carefully.
- Motorcycle racing is a very sophisticated sport, subject to many variables. The following information is theoretical only, and Kawasaki shall not be liable for any damages which might arise from alterations utilizing this information.
- When the motorcycle is operated on public roads, it **must** be in its original state in order to ensure safety and compliance with applicable regulations.

Carburetor:

Sometimes an alteration may be desirable for improved performance under special conditions when proper mixture is not obtained after the carburetor has been properly adjusted, and all parts cleaned and found to be functioning properly.

If the engine still exhibits symptoms of overly lean carburetion after all maintenance and adjustments are correctly performed, the main jet can be replaced with a smaller or larger one. A smaller numbered jet gives a leaner mixture and a larger numbered jet a richer mixture.

Spark Plug:

The spark plug ignites the fuel/air mixture in the combustion chamber. To do this effectively and at the proper time, the correct spark plug must be used, and the spark plug must be kept clean and adjusted.

Test have shown the plug listed in the "Electrical System" chapter to be the best plug for general use.

Since spark plug requirements change with the ignition and carburetion adjustments and with riding conditions, whether or not a spark plug of a correct heat range is used should be determined by removing and inspecting the plug.

When a plug of the correct heat range is being used, the electrodes will stay hot enough to keep all the carbon burned off, but cool enough to keep from damaging the engine and the plug itself. This temperature is about 400 – 800°C (750 – 1,450°F) and can be judged by noting the condition and color of the ceramic insulator around the center electrode. If the ceramic is clean and of a light brown color, the plug is operating at the right temperature.

A spark plug for higher operating temperatures is used for racing. Such a plug is designed for better cooling efficiency so that it will not overheat and thus is often called a "colder" plug. If a spark plug with too high a heat range is used – that is, a "cold" plug that cools itself too well – the plug will stay too cool to burn off the carbon, and the carbon will collect on the electrodes and the ceramic insulator.

The carbon on the electrodes conducts electricity, and can short the center electrode to ground by either coating the ceramic insulator or bridging across the gap. Such a short will prevent an effective spark. Carbon build-up on the plug can also cause other troubles. It can heat up red-hot and cause preignition and knocking, which may eventually burn a hole in the top of the piston.

Spark Plug

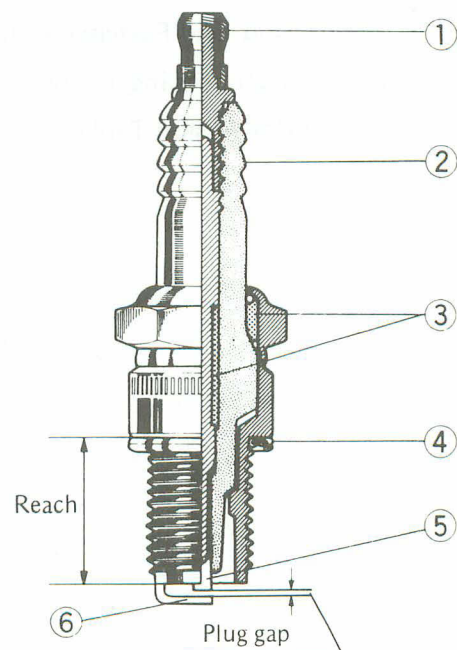

- | | |
|--------------|---------------------|
| 1. Terminal | 4. Gasket |
| 2. Insulator | 5. Center electrode |
| 3. Cement | 6. Side electrode |

Spark Plug Inspection

- Remove the spark plug and inspect the ceramic insulator.

Spark Plug Condition



Carbon fouling



Oil fouling

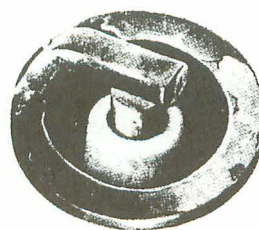

Normal operation



Overheating

★Whether or not the right temperature plug is being used can be ascertained by noting the condition of the ceramic insulator around the electrode. A light brown color indicates the correct plug is being used. If the ceramic is white, the plug is operating at too high a temperature and it should be replaced with the next colder type.

CAUTION

- If the spark plug is replaced with a type other than the standard plug, make certain the replacement plug has the same thread pitch and reach (length of threaded portion) and the same insulator type (regular type or projected type) as the standard plug.
- If the plug reach is too short, carbon will build up on the plug hole threads in the cylinder head, causing overheating and making it very difficult to insert the correct spark plug later.
- If the reach is too long, carbon will build up on the exposed spark plug threads causing overheating, preignition, and possibly burning a hole in the piston top. In addition, it may be impossible to remove the plug without damaging the cylinder head.

NOTE

○The heat range of the spark plug functions like a thermostat for the engine. Using the wrong type of spark plug can make the engine run too hot (resulting in engine damage) or too cold (with poor performance, misfiring, and stalling).

Plug Reach

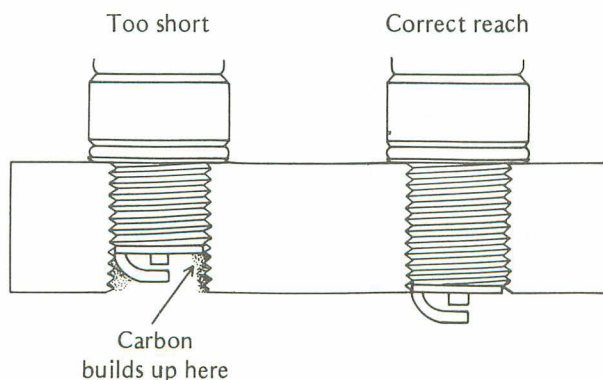

Standard Spark Plug Threads

Diameter:	10 mm
Pitch:	1.25 mm
Reach:	12.7 mm

16-4 APPENDIX

Troubleshooting Guide

NOTE

○This is not an exhaustive list, giving every possible cause for each problem listed. It is meant simply as a rough guide to assist the troubleshooting for some of the more common difficulties.

Engine Doesn't Start, Starting Difficulty:

Starter motor not rotating:

- Starter lockout or neutral switch trouble
- Starter motor trouble
- Battery voltage low
- Relays not contacting or operating
- Starter button not contacting
- Wiring open or shorted
- Ignition switch trouble
- Engine stop switch trouble
- Fuse blown

Starter motor rotating but engine doesn't turn over:

- Starter motor clutch trouble

Engine won't turn over:

- Valve seizure
- Rocker arm seizure
- Cylinder, piston seizure
- Crankshaft seizure
- Connecting rod small end seizure
- Connecting rod big end seizure
- Transmission gear or bearing seizure
- Camshaft seizure
- Alternator shaft bearing seizure
- Balancer bearing seizure

No fuel flow:

- Fuel pump trouble
- Fuel tank air vent obstructed
- Fuel filter clogged
- Fuel tap clogged
- Fuel line clogged
- Float valve clogged

Engine flooded:

- Fuel level in carburetor float bowl too high
- Float valve worn or stuck open
- Starting technique faulty
(When flooded, crank the engine with the throttle fully open to allow more air to reach the engine.)

No spark; spark weak:

- Battery voltage low
- Spark plug dirty, broken, or maladjusted
- Spark plug cap or high tension wiring trouble
- Spark plug cap not in good contact
- Spark plug incorrect
- IC igniter trouble
- Neutral, starter lockout, or side stand switch trouble
- Pickup coil trouble
- Ignition coil trouble
- Ignition or engine stop switch shorted
- Wiring shorted or open
- Fuse blown

Compression Low:

- Spark plug loose
- Cylinder head not sufficiently tightened down
- No valve clearance
- Cylinder, piston worn
- Piston ring bad (worn, weak, broken, or sticking)
- Piston ring/land clearance excessive
- Cylinder head gasket damaged
- Cylinder head warped
- Valve spring broken or weak
- Valve not seating properly (valve bent, worn, or carbon accumulation on the seating surface)

Poor Running at Low Speed:

Spark weak:

- Battery voltage low
- Spark plug dirty, broken, or maladjusted
- Spark plug cap or high tension wiring trouble
- Spark Plug cap shorted or not in good contact
- Spark plug incorrect
- IC igniter trouble
- Pickup coil trouble
- Ignition coil trouble

Fuel/air mixture incorrect:

- Pilot screw maladjusted
- Pilot jet, or air passage clogged
- Air bleed pipe bleed holes clogged
- Pilot passage clogged
- Air cleaner clogged, poorly sealed, or missing
- Starter plunger stuck open
- Fuel level in carburetor float bowl too high or too low
- Fuel tank air vent obstructed
- Carburetor holder loose
- Air cleaner duct loose

Compression low:

- Spark plug loose
- Cylinder head not sufficiently tightened down
- No valve clearance
- Cylinder, piston worn
- Piston ring bad (worn, weak, broken, or sticking)
- Piston ring/land clearance excessive
- Cylinder head warped
- Cylinder head gasket damaged
- Valve spring broken or weak
- Valve not seating properly (valve bent, worn, or carbon accumulation on the seating surface)

Other:

- IC igniter trouble
- Carburetors not synchronizing
- Vacuum piston doesn't slide smoothly
- Engine oil viscosity too high
- Drive train trouble
- Brake dragging
- Air suction valve trouble
- Vacuum switch valve trouble

Poor Running or No Power at High Speed:

Firing incorrect:

- Spark plug dirty, broken, or maladjusted
- Spark plug cap shorted or not in good contact

Spark plug incorrect
 IC igniter trouble
 Pickup coil trouble
 Ignition coil trouble

Fuel/air mixture incorrect:

Starter plunger stuck open
 Main jet clogged or wrong size
 Jet needle or needle jet worn
 Air jet clogged
 Fuel level in carburetor float bowl too high or too low
 Bleed holes of air bleed pipe or needle jet clogged
 Air cleaner clogged, poorly sealed, or missing
 Air cleaner duct poorly sealed
 Water or foreign matter in fuel
 Carburetor holder loose
 Fuel tank air vent obstructed
 Fuel tap clogged
 Fuel line clogged
 Fuel pump trouble

Compression low:

Spark plug loose
 Cylinder head not sufficiently tightened down
 No valve clearance
 Cylinder, piston worn
 Piston ring bad (worn, weak, broken, or sticking)
 Piston ring/land clearance excessive
 Cylinder head gasket damaged
 Cylinder head warped
 Valve spring broken or weak
 Valve not seating properly (valve bent, worn, or carbon accumulation on the seating surface.)

Knocking:

Carbon built up in combustion chamber
 Fuel poor quality or incorrect
 Spark plug incorrect
 IC igniter trouble

Miscellaneous:

Throttle valve won't fully open
 Vacuum piston doesn't slide smoothly
 Brake dragging
 Clutch slipping
 Overheating
 Engine oil level too high
 Engine oil viscosity too high
 Drive train trouble
 Air suction valve trouble
 Vacuum switch valve trouble

Overheating:**Firing incorrect:**

Spark plug dirty, broken, or maladjusted
 Spark plug incorrect
 IC igniter trouble

Fuel/air mixture incorrect:

Main jet clogged or wrong size
 Fuel level in carburetor float bowl too low
 Carburetor holder loose
 Air cleaner poorly sealed, or missing
 Air cleaner duct poorly sealed
 Air cleaner clogged
 Fuel pump trouble

Compression high:

Carbon built up in combustion chamber

Engine load faulty:

Clutch slipping
 Engine oil level too high
 Engine oil viscosity too high
 Drive train trouble
 Brake dragging

Lubrication inadequate:

Engine oil level too low
 Engine oil poor quality or incorrect

Gauge incorrect:

Water temperature gauge broken
 Water temperature sensor broken

Coolant incorrect:

Coolant level too low
 Coolant deteriorated

Cooling system component incorrect:

Radiator clogged
 Thermostat trouble
 Radiator cap trouble
 Thermostatic fan switch trouble
 Fan relay trouble
 Fan motor broken
 Fan blade damaged
 Water pump not turning
 Water pump impeller damaged

Over Cooling:**Gauge incorrect:**

Water temperature gauge broken
 Water temperature sensor broken

Cooling system component incorrect:

Thermostatic fan switch trouble
 Thermostat trouble

Clutch Operation Faulty:**Clutch slipping:**

Friction plate worn or warped
 Steel plate worn or warped
 Clutch spring broken or weak
 Clutch release mechanism trouble
 Clutch hub or housing unevenly worn

Clutch not disengaging properly:

Clutch plate warped or too rough
 Clutch spring tension uneven
 Engine oil deteriorated
 Engine oil viscosity too high
 Engine oil level too high
 Clutch housing frozen on drive shaft
 Clutch release mechanism trouble
 Clutch hub locknut loose
 Air in the clutch fluid line
 Clutch fluid leak
 Clutch fluid deteriorated
 Primary or secondary cup damaged
 Master cylinder scratched inside

Gear Shifting Faulty:**Doesn't go into gear; shift pedal doesn't return:**

Clutch not disengaging
 Shift fork bent or seized
 Gear stuck on the shaft

16-6 APPENDIX

- Gear positioning lever binding
- Neutral positioning lever binding
- Shift return spring weak or broken
- Shift return spring pin loose
- Shift mechanism arm spring broken
- Shift mechanism arm broken
- Shift pawl broken

Jumps out of gear:

- Shift fork worn
- Gear groove worn
- Gear dogs and/or dog holes worn
- Shift drum groove worn
- Gear positioning lever spring weak or broken
- Shift fork pin worn
- Drive shaft, output shaft, and/or gear splines worn

Overshifts:

- Gear positioning lever spring weak or broken
- Shift mechanism arm spring broken

Abnormal Engine Noise:

Knocking:

- IC igniter trouble
- Carbon built up in combustion chamber
- Fuel poor quality or incorrect
- Spark plug incorrect
- Overheating

Piston slap:

- Cylinder/piston clearance excessive
- Cylinder, piston worn
- Connecting rod bent
- Piston pin, piston holes worn

Valve noise:

- Valve clearance incorrect
- Valve spring broken or weak
- Camshaft bearing worn

Other noise:

- Connecting rod small end clearance excessive
- Connecting rod big end clearance excessive
- Piston ring worn, broken or stuck
- Piston seizure, damage
- Cylinder head gasket leaking
- Exhaust pipe leaking at cylinder head connection
- Crankshaft runout excessive
- Engine mounts loose
- Crankshaft bearing worn
- Primary gear worn or chipped
- Camshaft chain tensioner trouble
- Camshaft chain, sprocket, guide worn
- Air suction valve damaged
- Vacuum switch valve damaged
- Balancer gear worn or chipped
- Balancer shaft position maladjusted
- Balancer bearing worn
- Balancer or alternator shaft coupling rubber damper damaged
- Alternator shaft chain tensioner trouble
- Alternator shaft chain, sprocket, guide worn

Abnormal Drive Train Noise:

Clutch noise:

- Weak or damaged rubber damper

- Clutch housing/friction plate clearance excessive
- Clutch housing gear worn

Transmission noise:

- Bearings worn
- Transmission gears worn or chipped
- Metal chips jammed in gear teeth
- Engine oil insufficient

Drive chain noise:

- Drive chain adjusted improperly
- Chain worn
- Rear and/or engine sprocket worn
- Chain lubrication insufficient
- Rear wheel misaligned

Abnormal Frame Noise:

Front fork noise:

- Oil insufficient or too thin
- Spring weak or broken

Rear shock absorber noise:

- Shock absorber damaged

Disc brake noise:

- Pad installed incorrectly
- Pad surface glazed
- Disc warped
- Caliper trouble

Other noise:

- Bracket, nut, bolt, etc. not properly mounted or tightened

Oil Pressure Warning Light Goes On:

- Engine oil pump damaged
- Engine oil screen clogged
- Engine oil level too low
- Engine oil viscosity too low
- Camshaft bearings worn
- Crankshaft bearings worn
- Oil pressure switch damaged
- Wiring damaged
- Relief valve stuck open
- O-ring at the oil pipe in the crankcase damaged

Exhaust Smokes Excessively:

White smoke:

- Piston oil ring worn
- Cylinder worn
- Valve oil seal damaged
- Valve guide worn
- Engine oil level too high

Black smoke:

- Air cleaner clogged
- Main jet too large or fallen off
- Starter plunger stuck open
- Fuel level in carburetor float bowl too high

Brown smoke:

- Main jet too small
- Fuel level in carburetor float bowl too low
- Air cleaner duct loose
- Air cleaner poorly sealed or missing

Handling and/or Stability Unsatisfactory:**Handlebar hard to turn:**

- Steering stem locknut too tight
- Bearing damaged
- Steering bearing lubrication inadequate
- Steering stem bent
- Tire air pressure too low

Handlebar shakes or excessively vibrates:

- Tire worn
- Swing arm pivot bearing worn
- Rim warped, or not balanced
- Wheel bearing worn
- Handlebar clamp loose
- Steering stem head nut loose

Handlebar pulls to one side:

- Frame bent
- Wheel misalignment
- Swing arm bent or twisted
- Steering maladjusted
- Front fork bent
- Right/left fork legs unbalanced (oil level, air pressure, anti-dive setting)

Shock absorption unsatisfactory:

- (Too hard)
- Front fork oil excessive
- Front fork oil viscosity too high
- Front fork air pressure too high
- Rear shock absorber air pressure too high
- Tire air pressure too high
- Front fork anti-dive mechanism trouble
- Front fork bent
- (Too soft)
- Front fork oil insufficient and/or leaking
- Front fork oil viscosity too low
- Front fork air pressure too low
- Rear shock absorber air pressure too low
- Front fork, rear shock absorber spring weak
- Rear shock absorber oil leaking
- Front fork anti-dive mechanism trouble

Brake Doesn't Hold:

- Air in the brake line
- Pad or disc worn
- Brake fluid leak
- Disc warped
- Contaminated pad
- Brake fluid deteriorated
- Primary or secondary cup damaged
- Master cylinder scratched inside

Battery Discharged:

- Battery faulty (e.g., plates sulphated, shorted through sedimentation, electrolyte level too low)
- Battery leads making poor contact
- Load excessive (e.g., bulb of excessive wattage)
- Ignition switch trouble
- Alternator trouble
- Wiring faulty

Battery Overcharged:

- Alternator trouble

16-8 APPENDIX

General Lubrication

Lubrication

- Before lubricating each part, clean off any rusty spots with rust remover and wipe off any grease, oil, dirt, or grime.
- Lubricate the points listed below with indicated lubricant.

NOTE

○ *Whenever the vehicle has been operated under wet or rainy conditions, or especially after using a high-pressure spray water, perform the general lubrication.*

Pivots: Lubricate with Motor Oil.

Center Stand
Side Stand
Clutch Lever
Brake Lever
Brake Pedal
Rear Brake Rod Joint

Points: Lubricate with Grease.

Throttle Inner Cable Lower End
Speedometer Inner Cable*

*Grease the lower part of the inner cable sparingly.

Cables: Lubricate with Motor Oil.

Choke Cable
Throttle Cable

Cable Lubrication

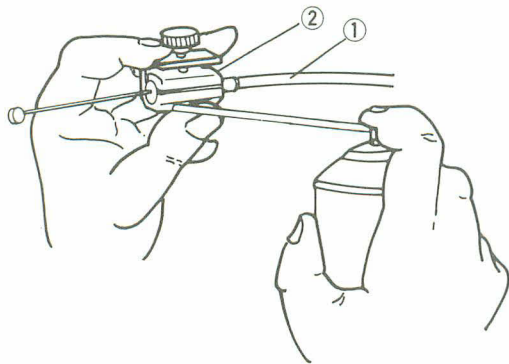

1. Cable
2. Pressure Cable Lube: K56019-021

Nut, Bolt, and Fastener Tightness

Tightness Inspection

- Check the tightness of the bolts and nuts listed here. Also, check to see that each cotter pin is in place and in good condition.

NOTE

○ *For the engine fasteners, check the tightness of them when the engine is cold (at room temperature).*

★ If there are loose fasteners, retorque them to the specified torque following the specified tightening sequence. Refer to the appropriate chapter for torque specifications. If torque specifications are not in the appropriate chapter, see the Standard Torque Table. For each fastener, first loosen it by ½ turn, then tighten it.

★ If cotter pins are damaged, replace them with new ones.

Nut, Bolt, and Fastener to be checked

Wheels:

Front Axle Nut
Front Axle Clamp Bolts
Rear Axle Nut
Chain Adjuster Clamp Bolts

Brakes:

Front Master Cylinder Clamp Bolts
Caliper Mounting Bolts
Rear Master Cylinder Mounting Bolt
Torque Link Nut
Brake Lever Pivot Nut
Brake Pedal Bolt
Brake Rod Joint Cotter Pin

Suspension:

Front Fork Clamp Bolts
Front Fender Mounting Bolts
Rear Shock Absorber Mounting Bolts
Swing Arm Pivot Shaft Nuts
Uni-trak Link Nuts

Steering:

Stem Head Nut
Handlebar Mounting Bolts

Engine:

Engine Mounting Bolts
Cylinder Head Bolts
Muffler Mounting Nuts
Muffler Mounting Bolts
Muffler Connecting Clamp Bolt
Clutch Master Cylinder Clamp Bolts
Clutch Lever Pivot Nut

Others:

Center Stand Bolts
Side Stand Bolt
Footpeg Mounting Bolts
Down Tube Mounting Bolts
Footpeg Bracket Mounting Bolts

Unit Conversion Table

Prefixes for Units:

Prefix	Symbol	Power
mega	M	x 1,000,000
kilo	k	x 1,000
centi	c	x 0.01
milli	m	x 0.001
micro	μ	x 0.000001

Units of Mass:

kg	x	2.205	=	lb
g	x	0.03527	=	oz

Units of Volume:

L	x	0.2642	=	gal (US)
L	x	0.2200	=	gal (imp)
L	x	1.057	=	qt (US)
L	x	0.8799	=	qt (imp)
L	x	2.113	=	pint (US)
L	x	1.816	=	pint (imp)
mL	x	0.03381	=	oz (US)
mL	x	0.02816	=	oz (imp)
mL	x	0.06102	=	cu in

Units of Force:

N	x	0.1020	=	kg
N	x	0.2248	=	lb
kg	x	9.807	=	N
kg	x	2.205	=	lb

Units of Temperature:

$$\frac{9 (^\circ\text{C} + 40)}{5} - 40 = ^\circ\text{F}$$

$$\frac{5 (^\circ\text{F} + 40)}{9} - 40 = ^\circ\text{C}$$

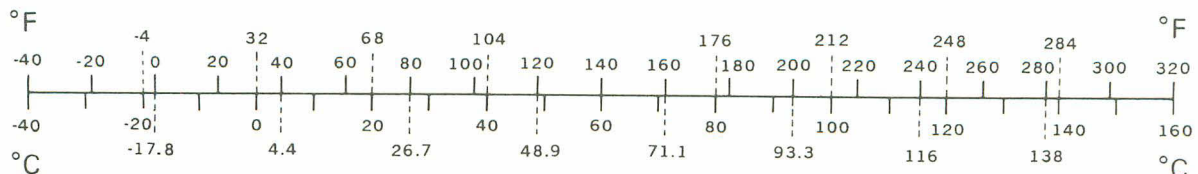

Units of Length:

km	x	0.6214	=	mile
m	x	3.281	=	ft
mm	x	0.03937	=	in

Units of Torque:

N-m	x	0.1020	=	kg-m
N-m	x	0.7376	=	ft-lb
N-m	x	8.851	=	in-lb
kg-m	x	9.807	=	N-m
kg-m	x	7.233	=	ft-lb
kg-m	x	86.80	=	in-lb

Units of Pressure:

kPa	x	0.01020	=	kg/cm ²
kPa	x	0.1450	=	psi
kPa	x	0.7501	=	cm Hg
kg/cm ²	x	98.07	=	kPa
kg/cm ²	x	14.22	=	psi
cm Hg	x	1.333	=	kPa

Units of Speed:

km/h	x	0.6214	=	mph
------	---	--------	---	-----

Units of Power:

kW	x	1.360	=	PS
kW	x	1.341	=	HP
PS	x	0.7355	=	kW
PS	x	0.9863	=	HP

表し。

スッパク。

4000

インジスベック

EX10 インジ本体写真

EX11 東洋証券のE-X1

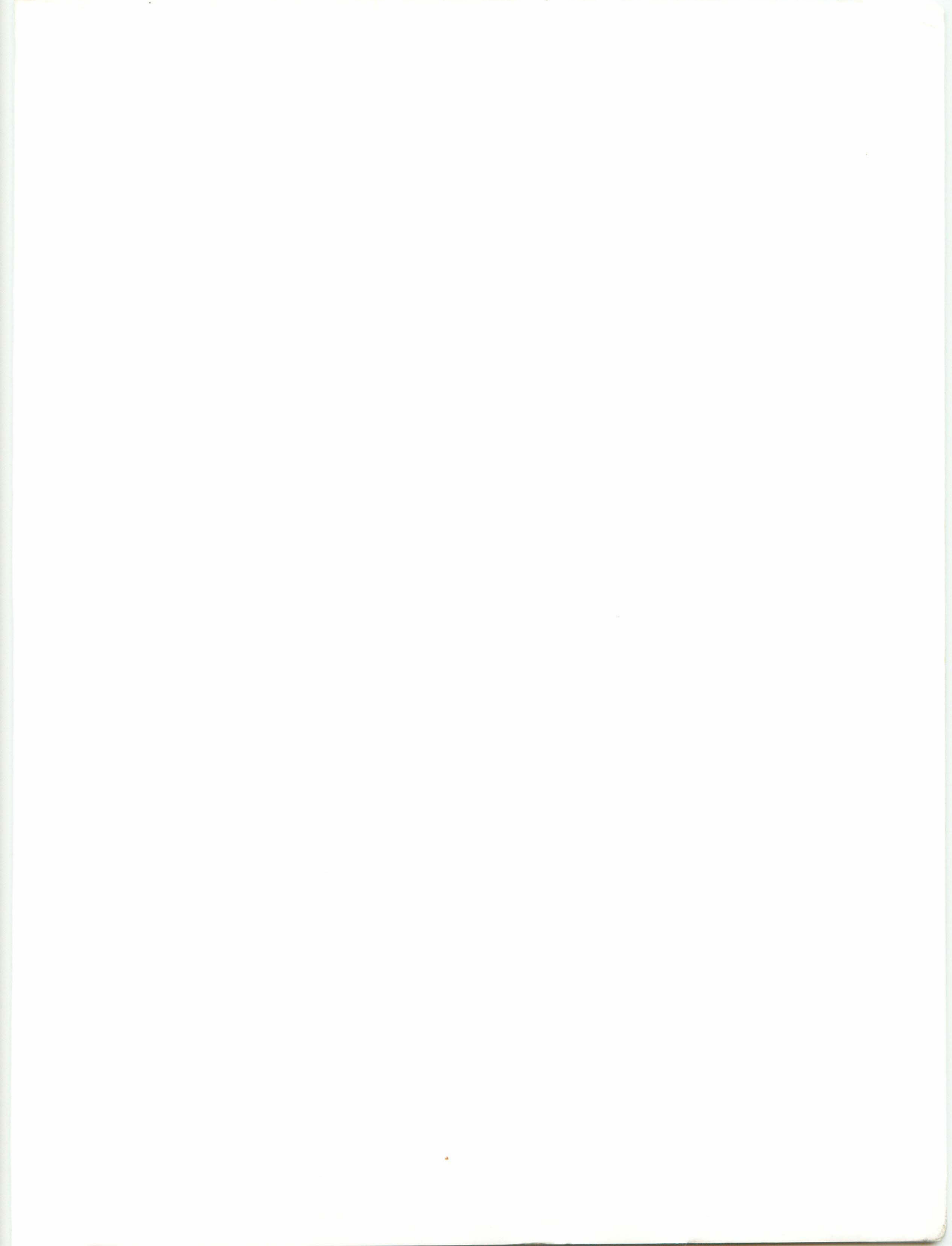

MODEL APPLICATION

Year	Model	Beginning Frame No.
1988	ZX1000-B1	JKAZXCB1□JA000001 or ZXT00B-000001 or 012452
1989	ZX1000-B2	JKAZXCB1□KA012001 or 017001 or ZXT00B-012001 or 017001
1990	ZX1000-B3	JKAZXCB1□LA028001 or ZXT00B-028001

□ : This digit in the frame number changes from one machine to another.

KAWASAKI
HEAVY INDUSTRIES, LTD.
CONSUMER PRODUCTS & COMPONENTS GROUP

Part No. 99924-1098-02

Printed in Japan.